

# APPROVAL

BY: \_\_\_\_\_ DATE: \_\_\_\_\_

- APPROVED, PROCEED WITH FABRICATION
- APPROVED AS NOTED, PROCEED WITH FABRICATION IN ACCORDANCE WITH COMMENTS
- DISAPPROVED, DO NOT FABRICATE

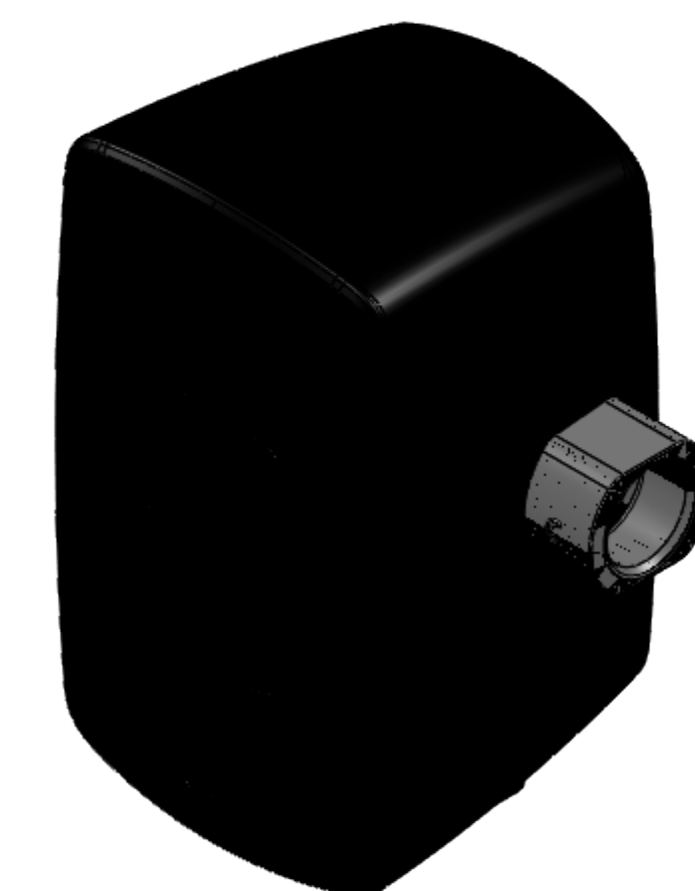
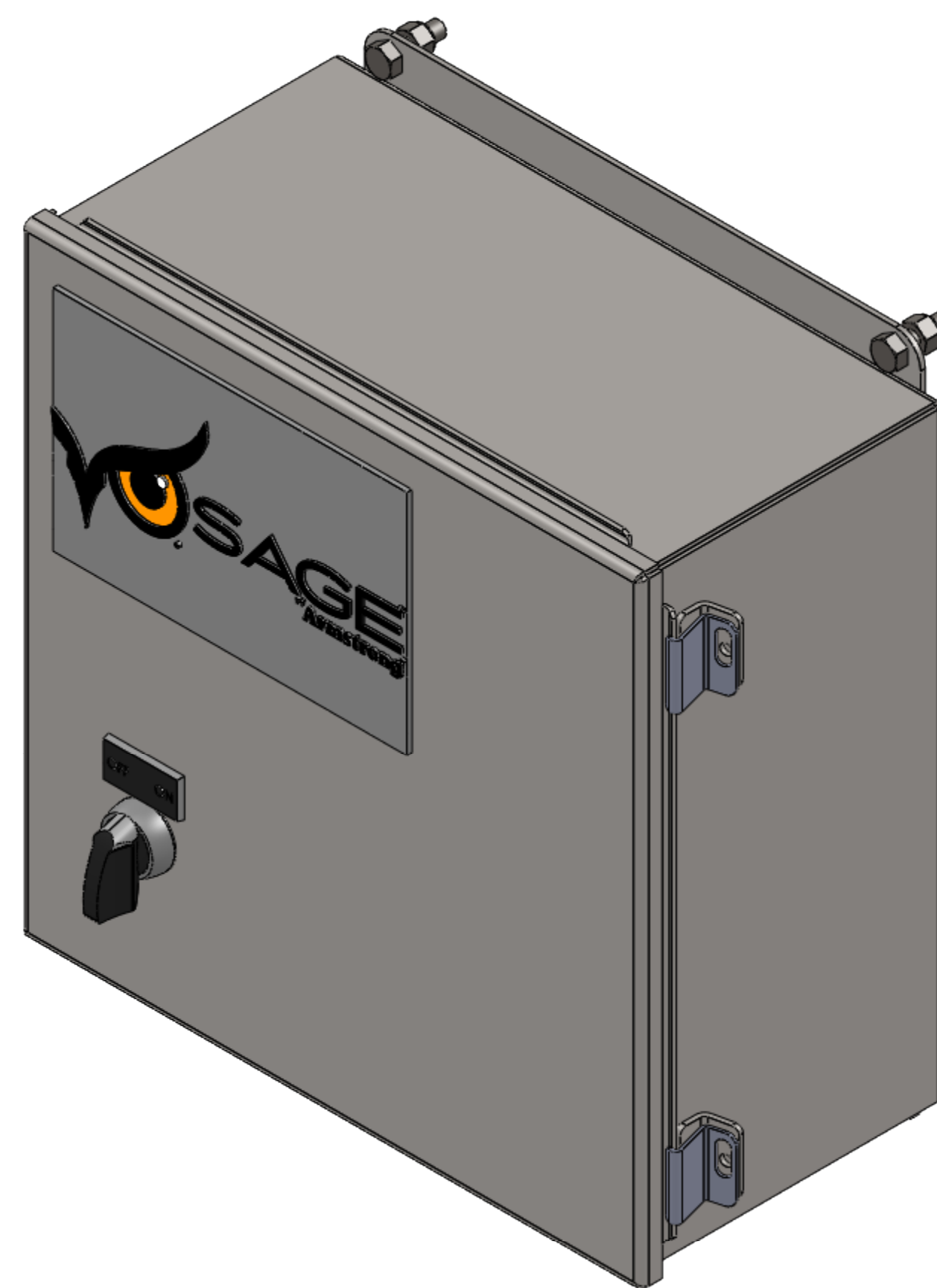
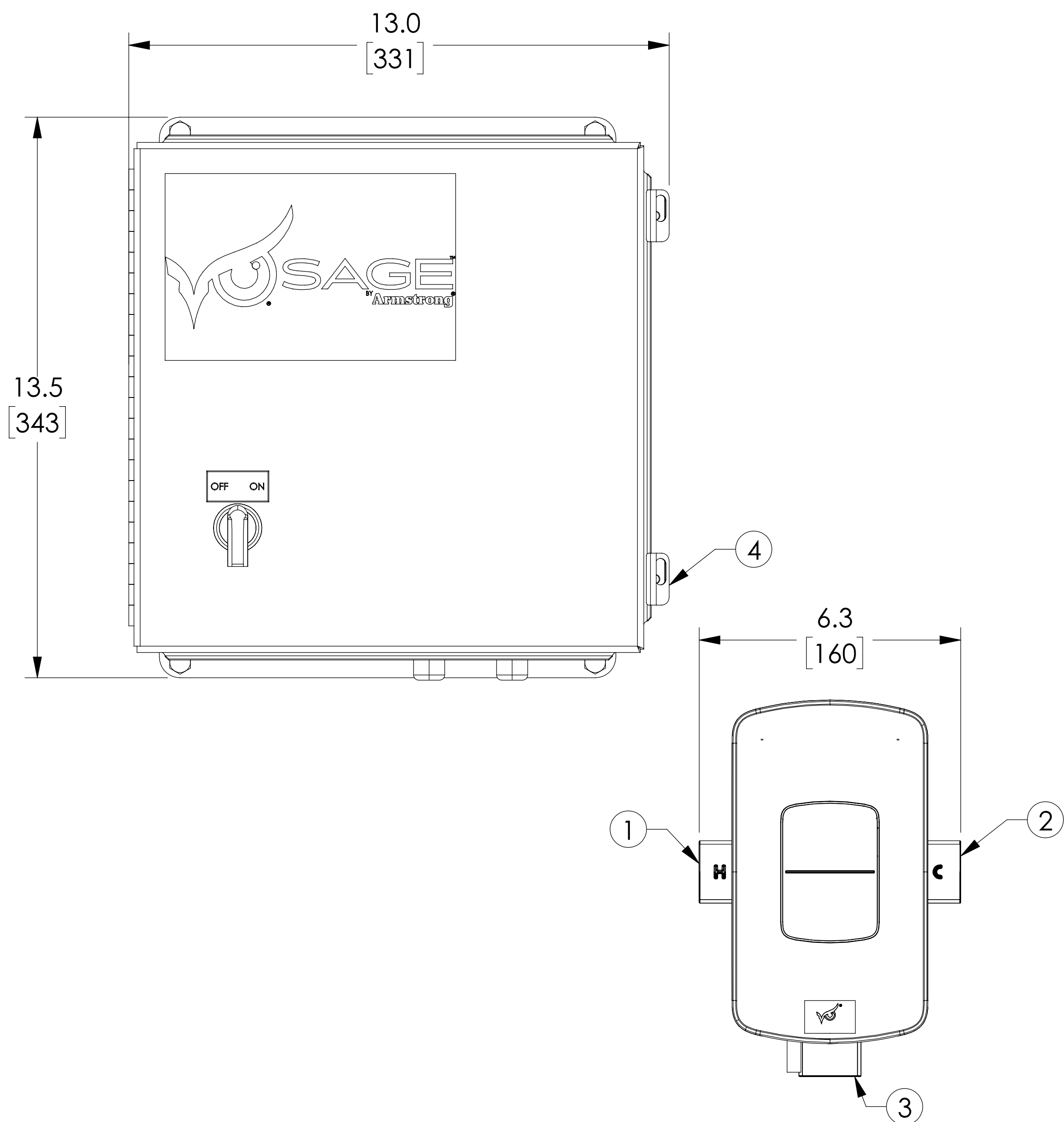

**PROJECT DESCRIPTION:**

**TAG:**

ITEM	DESCRIPTION	CONNECTION
1	HOT WATER INLET	1" NPT
2	COLD WATER INLET	1" NPT
3	MIXED WATER OUTLET	1" NPT
4	ELECTRICAL PANEL/SAGE	110 VAC @ 1.2A

DO NOT SCALE DRAWING TOLERANCES UNLESS OTHERWISE SPECIFIED	
DIMENSIONING ENGLISH [mm]	
FRACTIONAL ± 1/64 ANGULAR: ± 2	
DECIMAL	IN. MM
.XXX ± .005	.010
.XX ± .015	.10
.X	.3

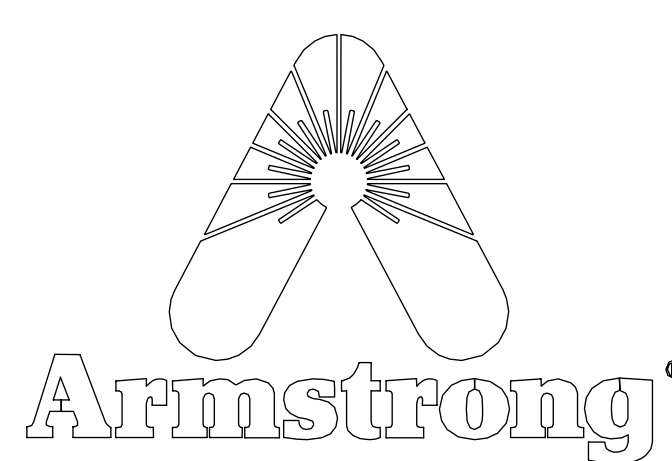
	
NAME	DATE
Kyle Bradford	12/18/2018
RELEASED	11/21/2018

<b>ARMSTRONG INTERNATIONAL</b> Copyright © 2010 ARMSTRONG INTERNATIONAL, INC.	
<b>DRV25BS</b>	
MATERIAL	SHEET 1 OF 1
CN66027	REV A DWG. SALES

NOTE(S):  
1. REFERENCE ARMSTRONG DRAWING D113501.