



Installation and Maintenance

ARMSTRONG "J" SERIES FLOAT AND THERMOSTATIC STEAM TRAPS, CONDENSATE CONTROLLERS, AND LIQUID DRAINERS

This bulletin should be used by experienced personnel as a guide to the installation and maintenance of J Series float and thermostatic steam traps, condensate controllers, and liquid drainers. Selection or installation of equipment should always be accompanied by competent technical assistance. We encourage you to contact Armstrong or its local representative if further information is required.

Armstrong "J" Series steam traps, condensate controllers, and liquid drainers have capacities to 25,000 lbs. of hot condensate per hour. The inlet and outlet connections are 2" NPT for operating pressures to 175 psig saturated steam.

TABLE 1: Orifice Sizes and Operating Pressures. This table gives the maximum operating pressures for each orifice size: DO NOT EXCEED RATED OPERATING PRESSURES.

INSTALLATION

1. Series "J" steam traps, condensate controllers, and liquid drainers have individual requirements for installation.
 - A) Float and Thermostatic Steam Trap
Install the trap so that its inlet connection is below the liquid level in the equipment to be drained. Figure 1 shows the recommended piping method.
 - B) Condensate Controller
The condensate controller's ability to handle flash steam enables it to operate efficiently with syphon drained equipment. Figure 2 shows the recommended piping method.
 - C) Liquid Drainer
Install the liquid drainer with its inlet connection below the liquid level in the equipment to be drained. Figure 3 shows the recommended piping for a liquid drainer.
 - 2) Before installing any trap, blow down the piping that leads to the unit's inlet. Use full line pressure. Be sure the maximum operating pressure (MOP) of the unit is adequate for the installation. (The MOP is stamped on the casting.)
 - 3) Set the unit as shown in Figure 1, 2, or 3, with the flange resting on the floor or on a platform for support. Then install and tighten the inlet and discharge piping to secure the unit in its operating position. Use good piping practices to avoid excessive strain on the piping.
 - 4) To allow for maintenance and provide maximum service, install a valve on each side of the unit, and a 2" Y-type strainer ahead of the inlet. All valves should be of the fullported type to avoid restricting flow.
-



ARMSTRONG "J" SERIES FLOAT AND THERMOSTATIC STEAM TRAPS,
CONDENSATE CONTROLLERS, AND LIQUID DRAINERS

Armstrong

NOTE: USE GOOD PIPING PRACTICES. MAKE INLET PIPING AS SHORT AS POSSIBLE WITH A MINIMUM OF ELBOWS AND OTHER RESTRICTIONS. INSTALL A DIRT POCKET IN THE LINE AHEAD OF THE UNIT AS SHOWN IN FIGURES 1, 2, AND 3.

- 5) LIQUID DRAINERS must be back vented to avoid air-binding. Do not reduce the pipe size to less than 1" for the back vent. Connect as shown in Figure 3. Use a full ported valve in the back-vent line. Remember that the pressure in the drainer is the same as in the unit drained. Only the difference in liquid levels produces flow. Minimize fittings and length of pipe between the vessel and the drainer.
- 5) If condensate is discharged to an overhead return, insure that adequate differential pressure exists across the trap to elevate the condensate. Install a check valve in the discharge piping near the unit to prevent backflow when the system is not in operation.
- 7) Series "J" units do not require priming. They are ready for operation when installed.

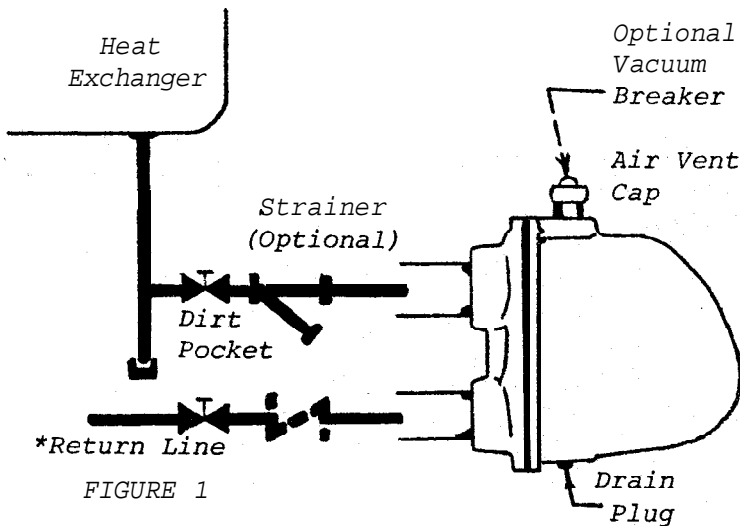

FIGURE 1

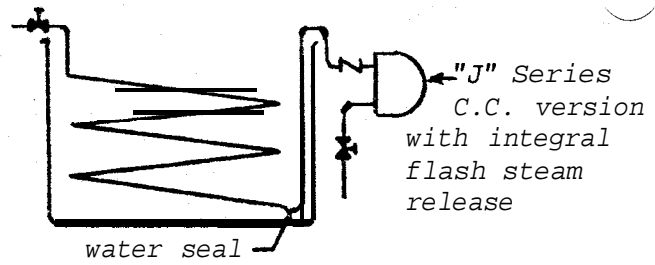

FIGURE 2

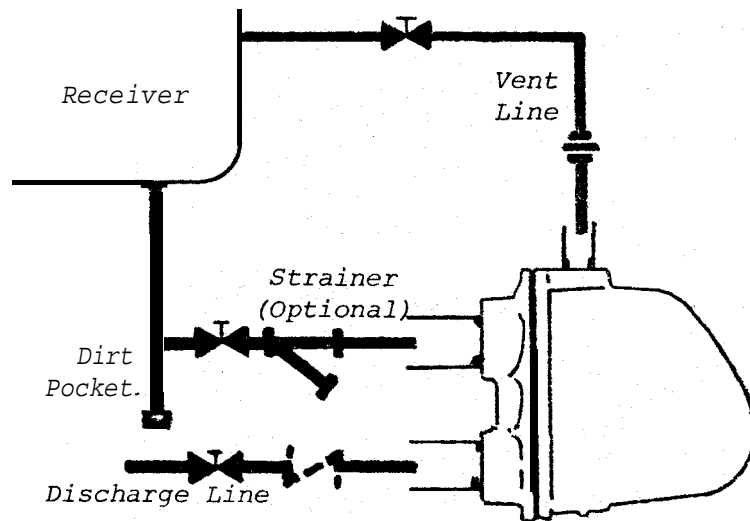

FIGURE 3



**ARMSTRONG "J" SERIES FLOAT AND THERMOSTATIC STEAM TRAPS,
CONDENSATE CONTROLLERS, AND LIQUID DRAINERS**

Armstrong
MADE IN THE U.S.A.

MAINTENANCE

Check the internal mechanism of these units for damage or wear at least once a year.

A) Opening the Unit

- 1) Close the valves in both supply and discharge lines. If the unit is hot, allow it to cool. (Liquid Drainer: close the valve in the back vent line.)
- 2) Remove the drain plug from the bottom of the body and allow the liquid to drain.

CAUTION: DO NOT ATTEMPT TO REMOVE THE BODY WITHOUT FIRST REMOVING THE THERMOSTATIC AIR VENT OR FIXED ORIFICE AND COUPLING.

- 3) Before removing the body.
 - a) Steam Trap. Remove the air vent cap (1 1/2" plug) from the top of the body. When the cap is removed, the thermostatic air vent extends through the top of the body. Using a spanner wrench or pliers, remove the thermostatic air vent and gasket. Inspect the vent for damage.
The valve should be away from the valve seat. If you have the facilities, place the air vent in a pan of water and heat it to boiling. The valve should close. If the bellows is collapsed or ruptured, or the valve and seat of the vent are eroded, discard it and install a new one.
If the unit includes a vacuum breaker, it is located in the air vent cap. Blow through the vacuum breaker from atmosphere side to be sure that it opens; suck air from that same side to be sure that it closes tightly. If the vacuum breaker does not operate properly, discard it and install a new one.
 - b) Condensate Controller. Remove the air vent cap from the body. Remove the fixed orifice air vent and the coupling from the air relief tube.
 - c) Liquid Drainer. Disconnect the back-vent or secondary steam piping from the drainer body.
- 4) Put blocks under the body of the unit to support it and remove the 8 bolts that attach the body to the cap. To facilitate handling, turn a lifting lug into the 1 1/2" NPT hole in the top of the body. A hoist can be attached to the lifting lug.
- 5) Carefully pull the body back from the cap, lifting slightly as you pull. Remove and discard the old gasket.
- 6) Inspect all of the moving-parts. Remove all worn or damaged parts and replace them with new parts. Figures 4,5,6, and 7 show all critical or moving parts. Check that each item is in good condition and operates normally. Inspect the lever and guide pin assembly for indications of wear. See that the float is not dented or corroded. Look for pinhole leaks in the float.



ARMSTRONG "J" SERIES FLOAT AND THERMOSTATIC STEAM TRAPS,
CONDENSATE CONTROLLERS, AND LIQUID DRAINERS

Arc!!!*

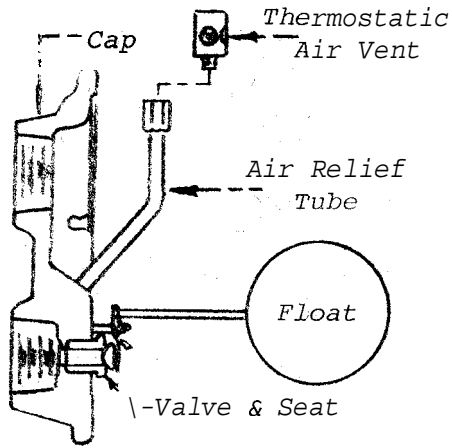

Figure 4. Float & Thermostatic Trap

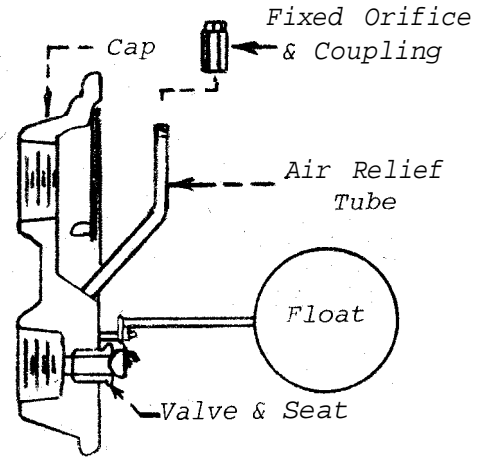

Figure 5. Condensate Controller

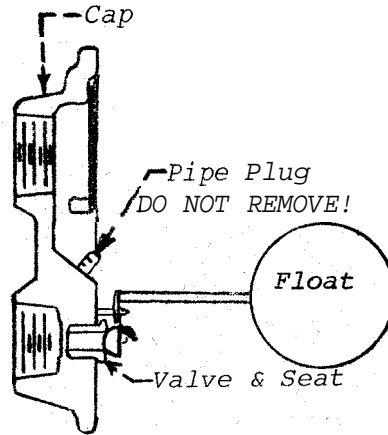

Figure 6. Liquid Drainer

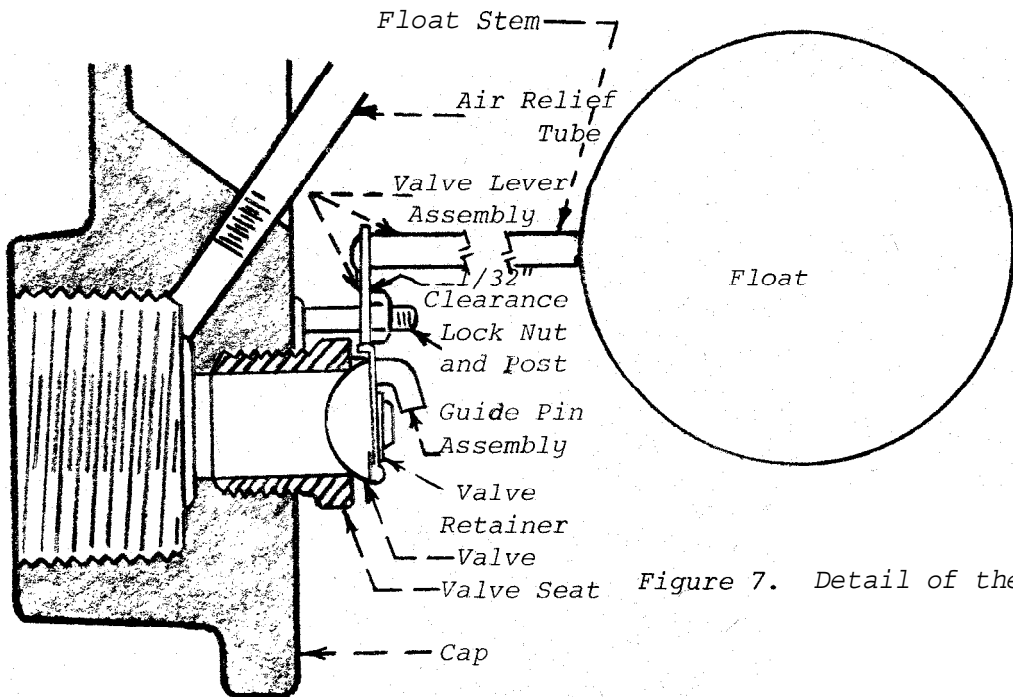

Figure 7. Detail of the mechanism



ARMSTRONG "J" SERIES FLOAT AND THERMOSTATIC STEAM TRAPS,
CONDENSATE CONTROLLERS, AND LIQUID DRAINERS

Armstrong

- 7) If parts are worn or damaged, refer to Section B, "Replacing The Mechanism".
- 8) After inspection and repair, clean the gasket surfaces and place a new gasket between the body and the cap. Replace the body carefully to avoid damaging the internal parts. Install and tighten the eight bolts.
- 9) Screw the drain plug into the bottom of the body and tighten it securely.
- 10) a) Steam Trap. Place the thermostatic air vent, with gasket installed, into the coupling at the top of the air relief tube. Tighten with a spanner wrench or pliers. Screw the air vent cap into the top of the body and tighten the cap with a wrench.
b) Condensate Controller. Screw the fixed orifice and coupling onto the upper end of the air relief tube. Screw the air vent cap into the top of the body and tighten with a wrench.
c) Liquid Drainer. Reconnect the back-vent piping.
- 11) Open the valves in the supply and discharge lines. For liquid drainers, also open the valve in the back-vent line. Check the equipment for normal operation.

3) Replacing The Valve and Seat

- 1) Remove the two (2) guide plate screws. The mechanism, except for the valve and seat, should be free from the cap.
- 2) Remove the valve seat from the cap. Be sure that the threads in the cap are not damaged and that the beveled mating surface in the cap is clean and free of erosion.
- 3) Install a new valve seat in the cap and tighten it securely. Pipe dope or lubricant must not be used on valve seat threads. The seal is made, not by the threads, but by metal to metal contact at the ground end of the valve seat. Make sure the seating area in the cap is clean before screwing the valve seat into position.

NOTE: THE VALVE AND SEAT ARE A LAPPED AND MATCHED SET. NEVER REPLACE ONLY A VALVE OR ONLY A VALVE SEAT. BE SURE THAT THE NEW VALVE AND **SEAT ARE** THE CORRECT ORIFICE SIZE FOR YOUR OPERATING PRESSURE. THE ORIFICE SIZE IS STAMPED ON THE VALVE SEAT, VALVE LEVER, AND GUIDE PIN ASSEMBLY. PARTS WITH DIFFERENT ORIFICE STAMPINGS SHOULD NEVER BE USED TOGETHER.

- 4) Install new valve, lever and guide pin assembly. Securely tighten the two guide plate screws. The lever simply hooks over the guide pins for installation.



Armstrong

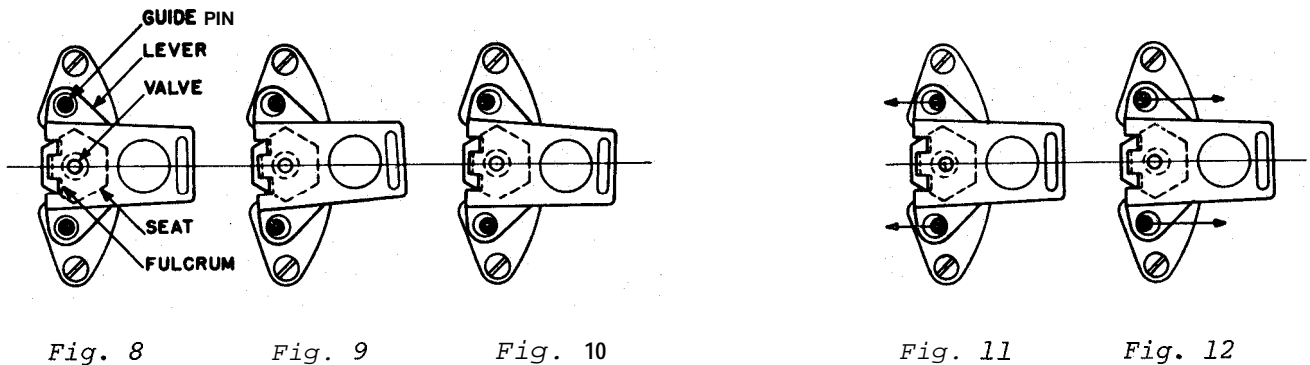

- 5) Check for alignment of the guide pins. Hold the lever and valve against the valve seat with the valve contacting its seat and the two fulcrum points resting on the face of the seat. When the lever is held in this position, the guide pins should be central in the guide pin holes as in Figure 8. When correctly aligned, the lever will move sideways the same distance to the right (Fig. 9) as to the left (Fig. 10).
Should the guide pins be out of line for any reason, they should be bent slightly so that they will be central in the guide pin holes as shown in Figure 8. For example, the guide pins in Figs. 11 and 12 are not properly aligned and should be tapped lightly with a hammer, or similar tool, in the direction of the arrows. If the pins are too far apart or too close together, a similar procedure should be followed to position them centrally.
- 6) Hold the valve in the valve seat with the lever's two fulcrum points resting on the face of the valve seat. Using an adjustable wrench, turn the lock nut down on its post until there is approximately $1/32$ " clearance between the nut and the extension of the valve lever which is under the nut. See Figure 7.
- 7) Be sure that the float is screwed tightly to the stem of the valve lever assembly, then install the body in accordance with steps 8-11 of MAINTENANCE.