

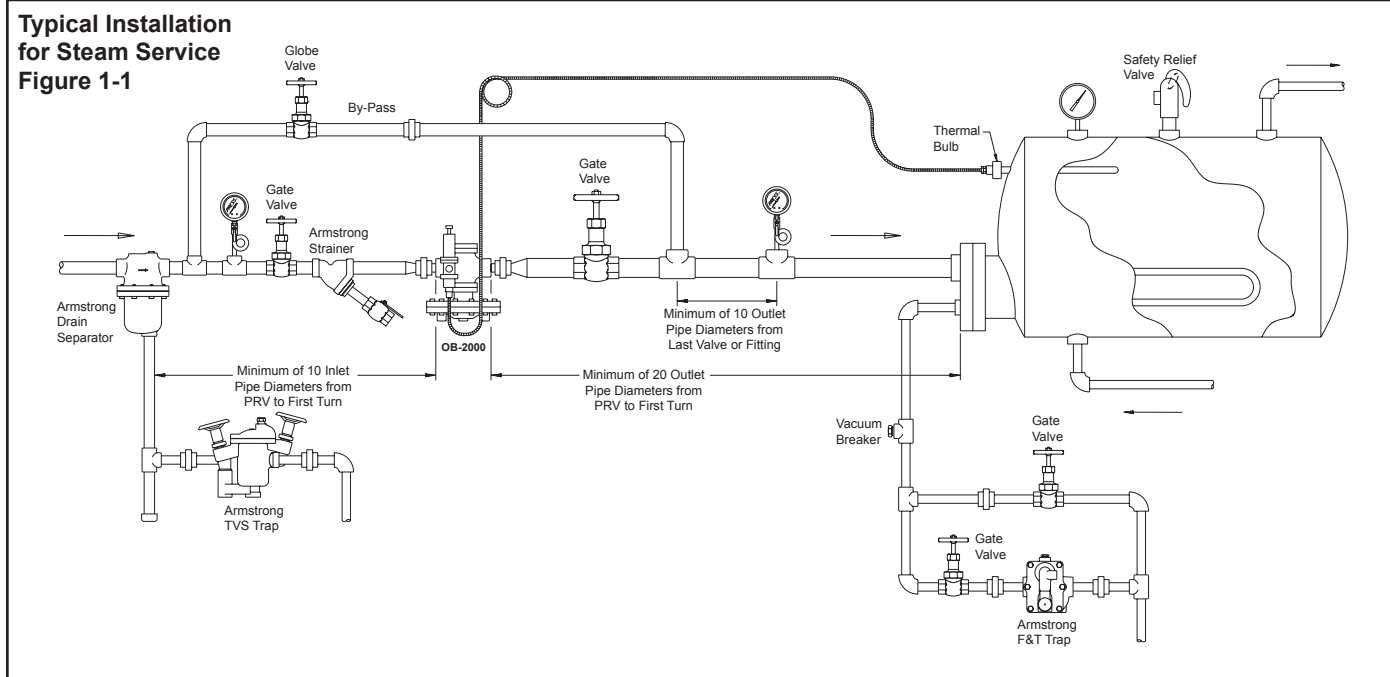

Model OB-2000 Temperature Regulating Valve

Installation and Maintenance Instructions



This bulletin should be used by experienced personnel as a guide to the installation of the Model OB-2000 Temperature Regulating Valve. Selection or installation of equipment should always be accompanied by competent technical assistance. You are encouraged to contact Armstrong International, Inc. or its local representative for additional information.

Installation Instructions

1. An Armstrong Inverted Bucket Steam Trap is recommended to drain condensate at the inlet of the temperature regulator.
2. An Armstrong 100 mesh "Y" strainer with blowdown valve should be installed before the temperature regulator to reduce the chance of dirt fouling.
3. Pressure gauges should be installed before and after the temperature regulator.
4. If required, a bypass line around the temperature regulator can be installed. Make sure the globe valve is of good quality and can be closed off tightly.
5. A vacuum breaker should be installed after the outlet of the heater coil and before the steam trap. Automatic air vents should also be installed at all points where non-condensables can collect.
6. Avoid lifting condensate directly after steam traps. Under light loads the pressure in the steam space is reduced and often is too low to lift condensate. Gravity drain to return pumps is recommended, or pipe in a safety drain trap. (Reference the Conservation Guidelines section in Catalog 326.)

Assembly and Installation

The main valve, temperature pilot adapter kit, and capillary system come unassembled and packed in 4 boxes. Please follow the directions enclosed with the valve to assemble unit.

Assembly

1. Detailed instructions on how to assemble pilot, tubing and main valve can be found on page 5 of this manual.

Installation of Body

1. Align flow direction with direction of arrow cast into body.
2. Install temperature regulator perpendicular to horizontal piping so that the diaphragm chamber is located at the bottom.

Installation of Capillary System and Thermal Bulb

1. After the pilot body has been installed, install the capillary system. See Figure 3-1 on Page 3. Be sure to insert bellows follower (10) as shown in Figure 2-1.
2. Thermal bulb (23) may be installed in any position. However, care should be taken so that at least three quarters of the thermal bulb is touching the heated fluid or air flow.
3. Screw in bushing (24) first and attach thermal bulb (23). See Figure 3-1 on Page 3.
4. Do not twist or bend capillary tube (26) sharply. Bending radius of capillary tube (26) should not be more than 1-1/2" inches. Position capillary tube (26) so that it does not touch steam lines.
5. Install a thermometer into the fluid close to the thermal bulb. See Figure 1-1 on Page 1.
6. When using the thermal bulb in a pipe, make sure the thermal bulb is installed in a location where the heated fluid flows freely around it.
7. If a thermal well is used make sure heat transfer compound is applied to the thermal bulb to take up any air gaps before installation into the thermal well.

Regulating Method

1. Close inlet and outlet valves to temperature regulator and open bypass line (if installed) to clean the system. Be sure to close the bypass line after cleaning the system. During blowdown, make sure that the temperature does not rise higher than the maximum limit of the capillary unit, otherwise damage to the capillary unit may occur.
2. Turn the adjusting screw (15) and align the gauge needle with the required temperature position on the dial. See Figure 2-1 and Table 3-1. Temperature will rise when turning clockwise (right) and temperature will fall when handle is turned counterclockwise (left).
3. Slowly open inlet and outlet valves completely.
4. Allow the system to stabilize and readjust according to the temperature reading on the thermometer.

Maintenance Inspection

1. Troubleshooting Hints - many of the problems that occur with temperature regulators are due to dirt holding the main or pilot valve open. Also make sure that the thermometer sensing the fluid temperature is operating correctly.

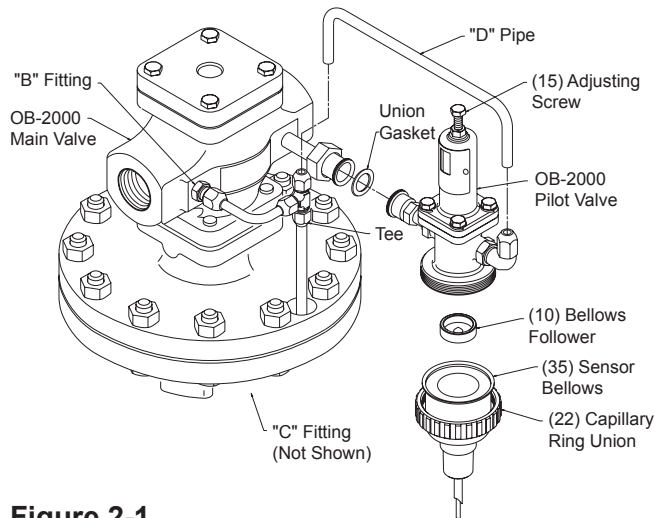

Figure 2-1

Disassembly

Caution: Be sure that the isolation valves at the inlet and outlet side of the regulator are closed and all internal pressure has been relieved before disassembly of the valve.

Temperature Pilot Valve Disassembly

See Figure 3-1 on Page 3.

1. Before removal of capillary system make sure the capillary system temperature is not exceeding the upper limit of the capillary range see Table 3-1. Otherwise capillary bellows rupture may occur. Remove thermal bulb first and let cool.
2. Loosen lock nut (16) and turn adjusting screw (15) counterclockwise (left), freeing up adjusting spring (14).
3. Remove four hexagonal bolts (17) from the pilot valve spring housing (2) and remove the adjusting spring (14), bottom spring plate (11), and spring plate follower (12).
4. Remove top bellows plate (6) and top bellows seal (5). Check for cracks in top bellows seal if you notice that condensate was present.
5. Loosen capillary ring/union (22) and temperature sensor bellows (35). **Make sure not to lose bellows follower (10).**
6. Loosen the guide (7) and remove the bottom bellows plate (8) and the bottom bellows seal (5) from the bottom half of the temperature pilot.
7. Remove pilot valve (3).
8. For assembly procedure, follow in reverse order.

Main Valve Disassembly

See Figure 3-2 on Page 3

1. Remove hexagonal bolts (38) from main valve cover (26) and remove cover from body (1).
2. Remove main valve spring (13) and the main valve (6).
3. Use a special socket up from the bottom of valve body to remove main valve seat (7).
4. Disconnect all tubing joints C, B and tee fitting. Reference Figure 2-1.
5. Remove all bolts (41) from diaphragm cases (4 and 5) separating both halves, remove diaphragm case, main diaphragms (12), retainer (11), and main spindle (9).

Assembly

1. Check to make sure there are not scratches on main valve (6) or seat (7). If there are scratches, apply lapping compound and re-lap valve and seat by hand with a back and forth motion (see lapping procedure Bulletin AY-786).
2. Make sure all sliding parts (main spindle (9)) move freely and are free of particulate build-up.
3. Assembling the main diaphragm case, make sure the main valve (6) is supported correctly by the main valve spring (13).
4. Confirm that the retainer (11) and main spindle (9) are connected correctly.

5. Make sure that a small bead of Never Seize® is used around the top and bottom circumferences of the diaphragms before assembly of bottom and top diaphragm cases.

6. Tighten hex bolts uniformly.

Note: Repair kits are available for temperature pilot valve, main valve, tubing, gaskets and diaphragms.

Capillary Range Table 3-1.

Number on Adjusting Dial	OB-2000 Capillary System Range °F					
	18 - 59	50 - 97	86 - 114	131 - 201	176 - 260	239 - 361
0	18 - 59	50 - 97	86 - 114	131 - 201	176 - 260	239 - 361
	12	39	72	113	154	214
1	28	59	99	142	192	266
2	43	77	120	169	225	307
3	57	93	136	196	257	352
4	70	109	153	223	297	410

Note: If upper limit of capillary temperature range is exceeded by 36°F., capillary bellows rupture may occur.

Figure 3-1. OB-2000 Pilot Valve

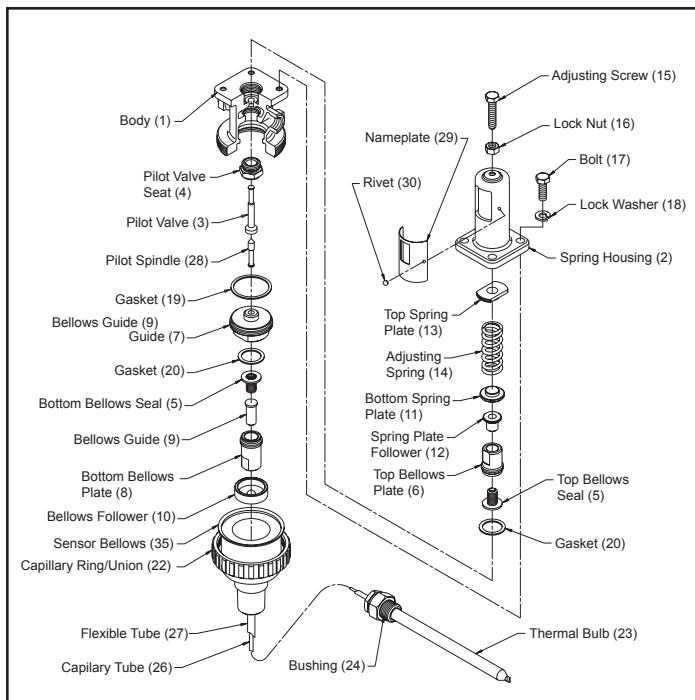
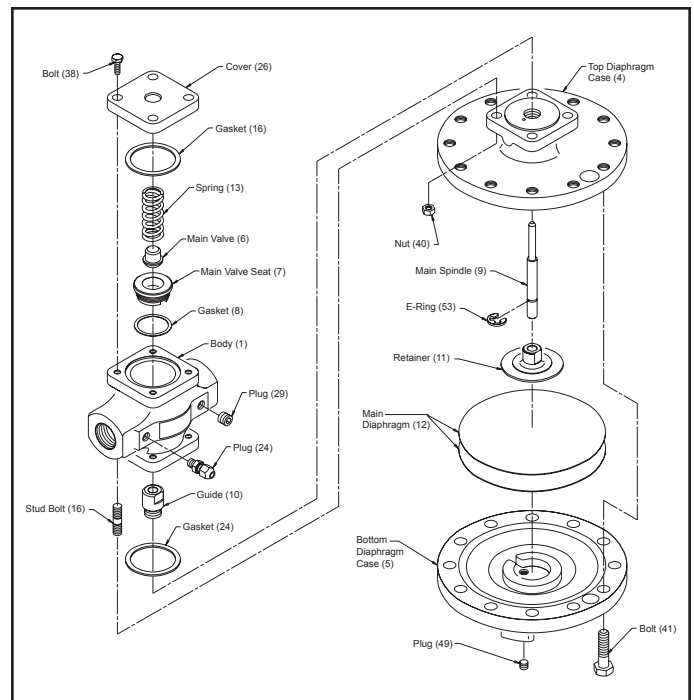

Figure 3-2. OB-2000 Main Valve



OB-2000 & GP-2000, K1, K3, K6

Remote Mount Pilot Tubing – Assembly Instructions

(See drawings for proper piping of remote pilots)

1. The valves have the following “similar” parts. 1/4” long nipple (4), 1/4”x 1/4” short nipple (6), fitting B (13) and union set (5). Use thread tape on the threads of both nipples.
2. Remove the 1/4” plug on the inlet side of the main valve body (1) (for GP-2000 remote mount pilot and OB-2000 temperature pilot) with an allen wrench.
3. Thread the 1/4” long nipple (4) into the main valve body (1) (in place of the 1/4” plug).
4. Thread one-half of the union set (5) onto the long nipple (4). Thread the other half onto the short nipple (6).
5. Thread the short nipple (6) into the pilot (2) or (3). **Note: The arrow on the side on the temperature pilot (3) must point away from the main valve. The short nipple (6) will thread into the bottom cap of the pressure pilot (2) (remote mount).**
6. Assemble the C-tube (8), B-tube (7) and tee (12) as shown in the diagrams on Page 6. Connect the union set (5) and tighten. **Very Important: Be sure that the groove on the Tee is on the top.**

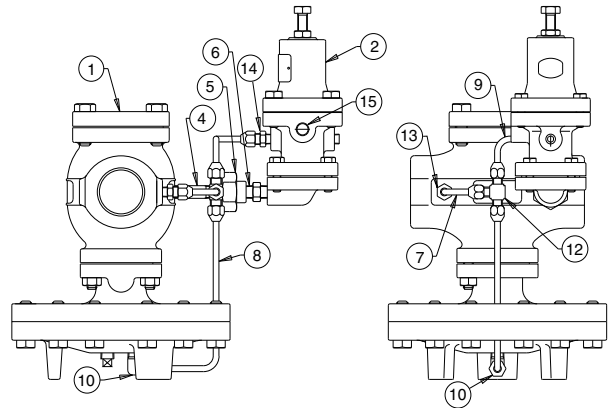

**GP-2000, GP-2000K-1,
GP-2000K-3, GP-2000K-6
Remote Mount**

For GP-2000 Remote Mounted Pilot

7. Place fitting A (14) into the pilot and thread into place. **Note: This fitting is open with no restricted opening. Use thread tape on threads.**
8. Once the union set (5) has been tightened to fitting A (14) of the pressure pilot (2) it should be facing the main valve (1). (See remote mount drawing)
9. Connect the S shaped D-tube (9) to the outlet of the pressure pilot at fitting A (14) and to top of the tee (12) and tighten. **Note: make sure the downstream sensing port (15) on the pilot faces downstream.**

For OB-2000

10. Thread the elbow (10) into the outlet of the temperature pilot (3) and into the bottom of the main valve as shown in drawings.
11. Place the D-tube (9) into the elbow (10) and the tee (12) and tighten.

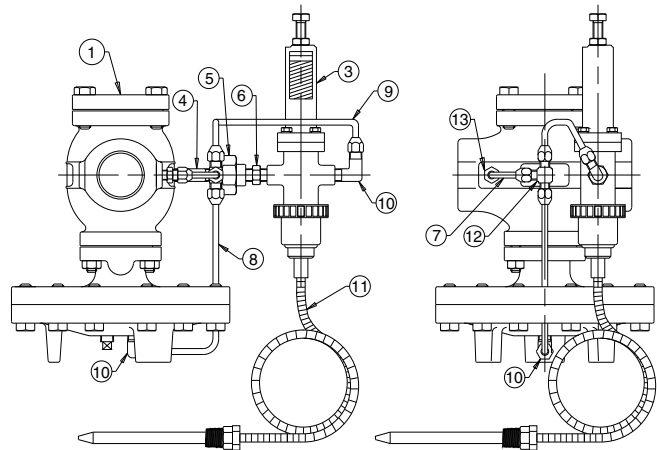

OB-2000

- 1 Main Valve Body
- 2 Pressure Pilot or Air Pilot (not shown)
- 3 Temperature Pilot
- 4 1/4” Long Nipple
- 5 Union Set
- 6 1/4” x 1/4” Short Nipple
- 7 B-Tube
- 8 C-Tube
- 9 D-Tube
- 10 Elbow
- 11 Capillary
- 12 Tee
- 13 Fitting B
- 14 Fitting A
- 15 Downstream Sensing Port

Troubleshooting Guide

Problem	Cause	Solution
Temperature regulator does not reach desired set temperature.	Improper adjustment.	Readjust according to <i>Regulating Methods</i> on page 2.
	Faulty steam trap draining equipment.	Check trap and correct problem.
	Inadequate pressure to eliminate condensate.	Repipe system.
	Orifice in "T" fitting is plugged.	Remove and clean.
	Main valve diaphragms are ruptured.	Replace main valve diaphragms.
	No transfer medium applied to thermal bulb.	Apply heat transfer paste to thermal bulb before installation in well.
	Incorrect capillary range.	Check label and change to correct range.
Temperature rises excessively.	Improper adjustment.	Readjust according to <i>Regulating Methods</i> on page 2.
	Dirt or scale on main valve (5) and main valve seat (6) or flawed valve and seat.	Disassemble and clean valve and seat, see Page 2 for <i>Disassembly</i> . In case of flawed valve and seat - replace.
	Dirt or scale on pilot valve (3), pilot valve and seat (4).	Disassemble pilot and clean. See page 2 for <i>Disassembly</i> . Replace if damaged.
	Bellows follower (10) was not installed.	Install bellows follower.
	Orifice in "T" fitting is plugged.	Clean.
	Broken capillary system.	Replace capillary system.
	Bypass line leaks.	Repair bypass.
Large variation between thermometer and temperature regulator setting.	Thermal bulb or thermometer are installed in wrong location.	Relocate thermal bulb in path of fluid so at least 3/4 of bulb is submerged in fluid and/or relocate thermometer closer to thermal bulb.
	Inlet pressure too high.	Lower inlet pressure. On low load applications, the lower the inlet pressure, the more stable the control will be.
	Dirt or scale on pilot valve (3), and pilot valve seat (4).	Disassemble, clean by replacing.
External leaks.	Leaks from body gasket.	Replace gaskets.
	Broken bottom seal bellows in pilot.	Replace bottom seal bellow.

**Main Valve Kits
K-2100 thru K-2108**

- 1 Main Valve
- 1 Main Body Top Gasket
- 1 Body Spacer Gasket

**Main Diaphragm Kits
K-2130 thru K-2136**

- 2 Main Diaphragms
- Never-Seeze[®] compound

**Gasket Sets
K-2380 thru K-2386**

- 1 Screen
- 1 Main Body Top Gasket
- 1 Main Body Bottom Gasket
- 1 Body Spacer Gasket

**Adapter Kits
OB-2000
K-2020 thru K-2026**

All external tubing and fittings needed to mount pilot valves to main valves.

**Temperature Pilot Kit
K-2611**

- 1 Pilot Valve
- 1 Pilot Valve Seat
- 2 Top Bellows Seal
- 2 Seal Bellows Gasket
- 1 Gasket Top Guide
- 1 Bellows Follower