

FLO-RITE-TEMP

INSTANTANEOUS WATER HEATER INSTALLATION AND ADJUSTMENT INSTRUCTIONS FOR SINGLE AND DOUBLE WALL UNITS



This bulletin should be used by experienced personnel as a guide to the installation of the FLO-RITE-TEMP Instantaneous Water heater. Selection or installation of equipment should always be accompanied by competent technical assistance. You are encouraged to contact Armstrong International, Inc. or its local sales representative for additional information.

FLO-RITE-TEMP

INSTANTANEOUS WATER HEATER INSTALLATION AND ADJUSTMENT INSTRUCTIONS

NOTICE

No water heater will work satisfactorily if improperly installed and operated. These instructions contain important information for the installation and adjustment of the **FLO-RITE-TEMP** Water Heaters. Read these instructions carefully before installing this unit. **FAILURE TO ADHERE TO THESE INSTRUCTIONS COULD RESULT IN SERIOUS BODILY INJURY OR PROPERTY DAMAGE.**

STEAM PIPING INSTALLATION OF A SINGLE UNIT

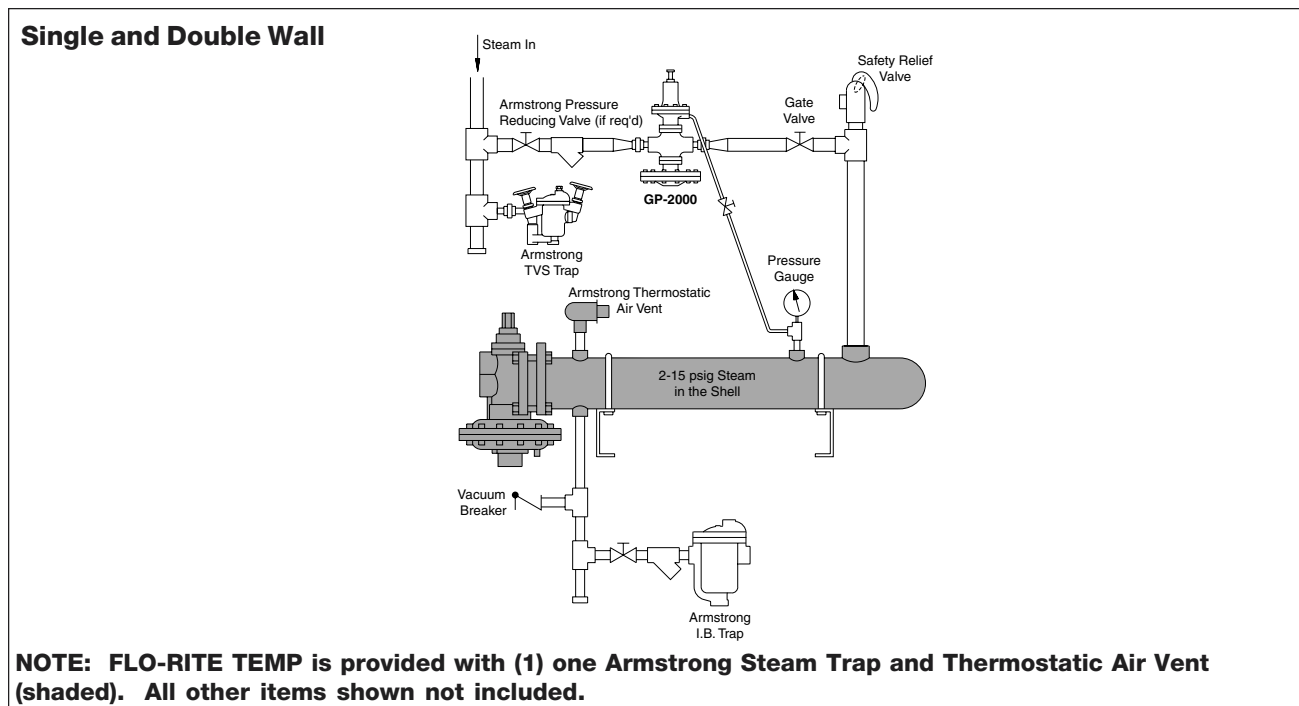

Fig. 2-1

NOTE: units may be piped in parallel for larger capacity requirements. See Fig. 15-1 for an example of parallel unit installation.

The unit includes the mixing valve mounted to the heat exchanger, channel iron and U-bolts mounted, thermostatic air vent installed on the heat exchanger, a water pressure pop off valve integral to the unit control valve and a separate Armstrong Inverted Bucket Steam Trap.

STEAM SIDE INSTALLATION

(Refer to Fig. 2-1)

1. Install the FLO-RITE-TEMP with adequate room to allow for tube bundle removal when cleaning is required. See Table 12-1 for specific dimensions.
2. If 2-15 psig of steam is available a pressure reducing valve is NOT required. If a pressure reducing valve is required, an Armstrong Inverted Bucket Steam Trap is recommended to drain condensate at the inlet of the pressure reducing valve.
3. An Armstrong Y-strainer should be installed before the pressure reducing valve to reduce the chance of dirt fouling.

4. If an externally piloted pressure reducing valve is used, the control pipe should be pitched away from the PRV and installed at the pressure gauge on the shell of the heat exchanger.
 5. A steam safety relief valve should be used prior to the heat exchanger if either or both of the following conditions exist. (1) If the maximum steam pressure could exceed the minimum water pressure in the tubes, or (2) The maximum steam pressure could exceed 150 psig (the maximum steam pressure rating of the shell).
- IMPORTANT -Steam supply pipe size coming to the heat exchanger should NOT be smaller than the steam connection supplied on the heater, otherwise steam flow could be restricted. If a pressure reducing valve is used, installation should be as close as possible to the Flo-Rite-Temp. Downstream piping from the Pressure Reducing Valve should be expanded immediately after the PRV to accomodate the expanded volume of steam.**
6. To vent start-up air, an Armstrong Thermostatic Air Vent is included and installed on the top connection, opposite the trap drain connection of the heat exchanger. This discharge can be piped to drain or the floor if preferred.
 7. Install a vacuum breaker in the piping between the heat exchanger drain connection and the steam trap. This will prevent improper draining of the heat exchanger caused by a possible vacuum forming when the steam is shut off.
 8. Install a suitable steam pressure gauge in the 1/4" coupler located in the top mid section of the heat exchanger shell. This gauge will help diagnose pressure problems should they occur. This port may also be used for a PRV external control pipe if a PRV is required.

WATER PIPING INSTALLATION

(Follow same plumbing for DW units)

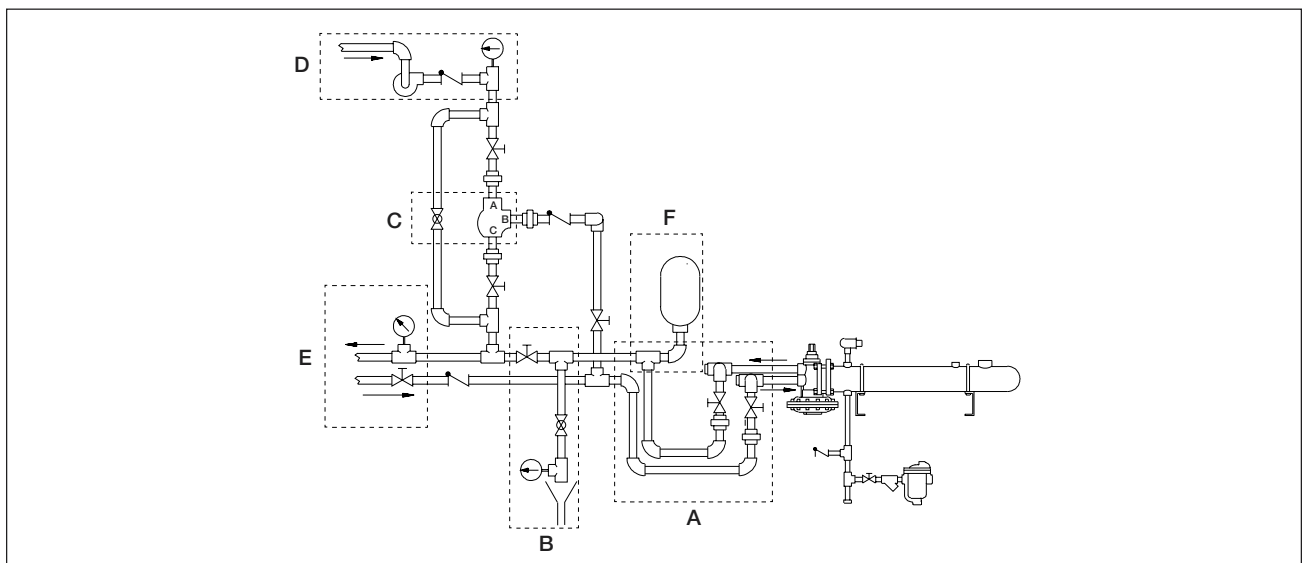

Fig. 3-1

1. An 18 inch minimum thermal loop should be piped into the water inlet and outlet of the FLO-RITE-TEMP and should be located as close to the mixing valve as possible (See Fig. 3-1A). These loops will act as a thermal check valve or heat trap to prevent the conduction of heat through the water from the unit during inactive times.
2. Isolation valves and hose connections added to both the inlet and outlet water supplies will allow for Clean-In-Place equipment to be utilized.
3. Use pipe unions on both the water inlet and outlet to allow ease of water heater mixing valve removal for maintenance and removal of the tube bundle for cleaning (See Fig. 3-1A).
4. For adjusting the unit, an isolation valve and hot water by-pass to drain should be installed close to the unit downstream from the thermal loops and prior to the recirculation loop (if one is used) (See Fig. 3-1B). This allows for quick and easy setting of the FLO-RITE-TEMP by one person. By isolating the unit from the hot water system, flow can be controlled to drain through the globe valve while monitoring outlet water temperature during low and high flow adjustments on the water heaters mixing valve.

Minimum line sizes to drain should be as follows: model 415 = 3/4", model 535 = 1", model 665 = 1-1/4", model 8120 = 2". Line sizes smaller than these will not allow sufficient flow for making high flow settings on the mixing valve.

5. A water temperature gauge should be installed directly after the by-pass drain valve. This thermometer is only used for initial temperature adjustments of the Flo-Rite-Temp or troubleshooting the unit. (See Fig. 3-1B)
6. If a recirculation system is used with a FLO-RITE-TEMP, a small diverting valve must be piped into the loop return downstream of the recirculating pump (See Fig. 3-1C). This device is used to divert recirculated water back to the heater for reheating if the temperature of the water drops too low due to no hot water demand from the system plus piping radiation losses (See page 9 for operation explanation). Be sure to pipe in unions and isolation valves to facilitate diverting valve removal required when element replacement is needed. A throttling type valve should be installed in a full return line size bypass around the diverting valve in order to balance the flow to the diverting valve. This is especially needed when recirculating pumps are large or oversized.

7. For a recirculated system, a small constant running pump should be piped in on the return side of the loop (See Fig.3-1D). This pump should be sized to move approximately 10% of the maximum rated gpm of the FLO-RITE-TEMP in the system with enough head to overcome the head encountered in the loop.

NOTE: A thermometer should be installed in the outgoing loop to monitor system temperature (Fig. 3-1E). A thermometer may also be installed on the loop return to monitor temperature drop through the loop or to help troubleshoot the diverting valve (Fig. 3-1D). The thermometer referred to in point #4 and Fig. 3-1B should only be used to set the FLO-RITE-TEMP and never used to monitor system temperature.

NOTE: Expansion tanks should be used in on/off demand applications where there is a short duration of time from high flow to no flow of water, i.e., a shut off time of 10 seconds or less. (See Fig. 3-1F)

Pop-Off Valve Installation Instructions

1. Thread relief valve into the 1/4" NPT port located on the lower diaphragm half near the spring chamber. See drawing 4-1.
2. Tighten with a 3/4" wrench. Warning: Do Not Over Tighten. Distortion can result causing the relief valve not to seat.

Note: The discharge of the relief valve is 1/4" FPT and can be piped over to a drain to prevent the relief valve discharge from going onto the floor underneath the Flo-Rite-Temp.

Note: The function of this pressure relief valve is to relieve any excess pressure on the water side of the Flo-Rite-Temp resulting from system water hammer or water expansion pressure due to water heating. If the problem is severe, water hammer arrestors should be placed on all equipment with fast closing water valves. Expansion tanks should be used for all expansion pressure problems. The relief set point of this valve is 165 psig.

Note: The Armstrong Flo-Rite-Temp comes supplied with a 1/4" NPT water pressure relief valve. The standard valve has a cracking pressure of 165 psig. Installation instructions (AY-700) are

supplied with each heater. The valve is a self relieving and self seating valve which will open due to thermal expansion or hydrolic shock. Continuous or intermittent discharge of this valve while heater is in service could indicate a system pressure problem. See note for (Figure 3-1F) expansion tanks on previous page possible solutions.

Drawing 4-1.

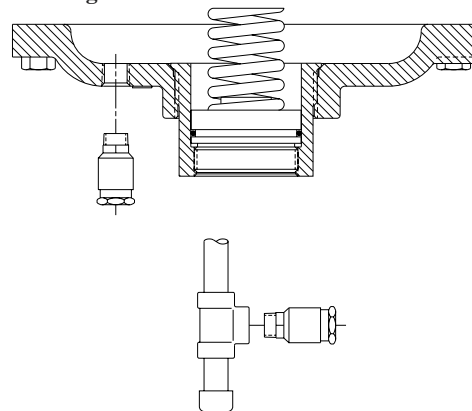

Note: For hard water applications, pipe pop-off valve into a dirt leg.

OPTIONAL SAFETY EQUIPMENT

See Fig. 3-1E for location of each option within the system. All options would be installed downstream of the water heater in the outgoing recirculation loop, if one is present, or downstream of the hot water thermal loop if recirculation is not used but always before the first hot water take off from the system.

Option #1 A temperature relief valve set at roughly 15-30 degrees above that of the FLO-RITE-TEMP will help prevent any chance of overheated water reaching the faucets. (NOTE: Normally unit will fail closed and either no water or only cold water will flow from the unit.)

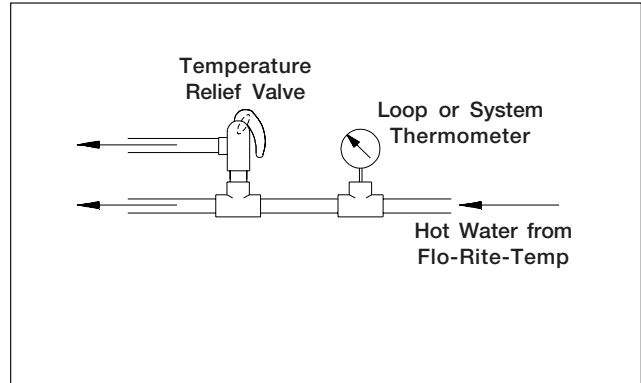

Option #1

Option #2 A 3-way blending valve with a set point 10-30 degrees above that of the FLO-RITE-TEMP will help prevent the chance of overheated water reaching the faucets in the event of unit failure. Under normal operating conditions the hot water flows straight through the blending valve from Port B to Port A. But in the event of an overheated situation, the blending valve will open Port C to add sufficient cold water to maintain a constant temperature. (NOTE: The blending valve should be sized to handle the maximum flow of the system).

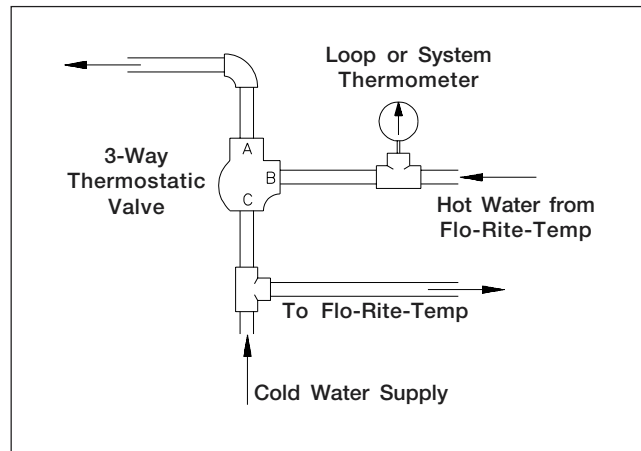

Option #2

Note: The Armstrong Flo-Rite-Temp comes supplied with a 1/4" NPT water pressure relief valve. The standard valve has a cracking pressure of 165 psig. Installation instructions (See AY-700) are supplied with each heater. The valve is a self relieving and self seating valve which will open due to thermal expansion or hydrolic shock continuous or intermiten discharge of this valve while heater is in service could indicate a system pressure problem. See note for (fig. 31F) on previous page for possible solution.

Option #3 A temperature switch installed well downstream of the Flo-Rite-Temp outlet on a non-recirculated system or just into the outgoing recirculated system loop on a recirculated system, with a set point 15-30 degrees above that of the FLO-RITE-TEMP will help prevent the chance of overheated water reaching the faucets in the event of system problems. This switch can be used to turn off the steam supply to the heater in the event of overheating. The most economical way to accomplish this is with a solenoid on the PRV. A full ported motorized valve on the steam supply line may also be used. Option 3B. Along these same lines, a pressure switch installed in the inlet water line would shut down the supply steam on the heat exchanger in the event of water pressure loss, preventing thermal shock and water hammer to the unit.

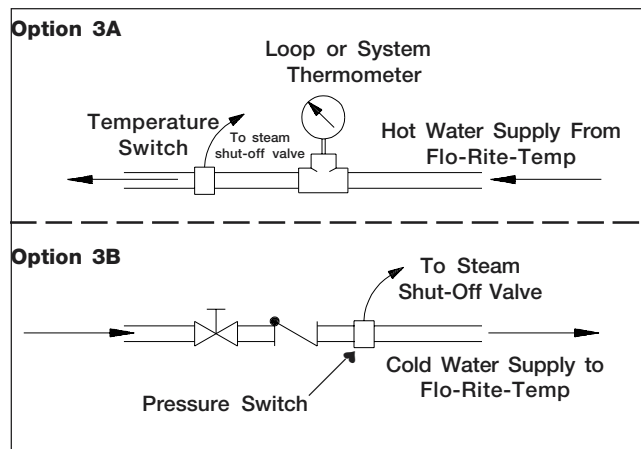

Option #3

Option #4 (Available only when a pressure reducing station is installed on the Flo-Rite-Temp). Using the Model GP-2000W1P system, when piped as shown in the Option 4 drawing, will provide a safe dependable shut down of the main steam valve when the water pressure fails or drops rapidly on the Flo-Rite-Temp. Unlike a solenoid application, which shuts the steam down when the water pressure drops below a pre-set point, the GP-2000W1P offers another benefit that it allows the system to keep producing hot water even when the water pressure is below the set pressure. The GP-2000W1P Combination valve essentially lets the steam pressure modulate below the water pressure by 2 or 3 pounds, allowing a water heater to supply hot water even when water pressure is low.

Incoming cold water is piped into the hot water heater with a sample line piped to the W-1 Pilot of GP-2000W1P. At the same time the cold water is supplying the water heater, its pressure it is also supplying the W-1 Pilot. When the pressure of the incoming cold water decreases, the W-1 Pilot modulates down the supply of steam to the pressure pilot controlling the main steam valve, acting as a non-electric self-controlled shutdown device. Ultimately, this valve eliminates the use of any electricity and gives the customer safe control of their hot water supply when water pressure loss or fluctuating water pressure conditions exist.

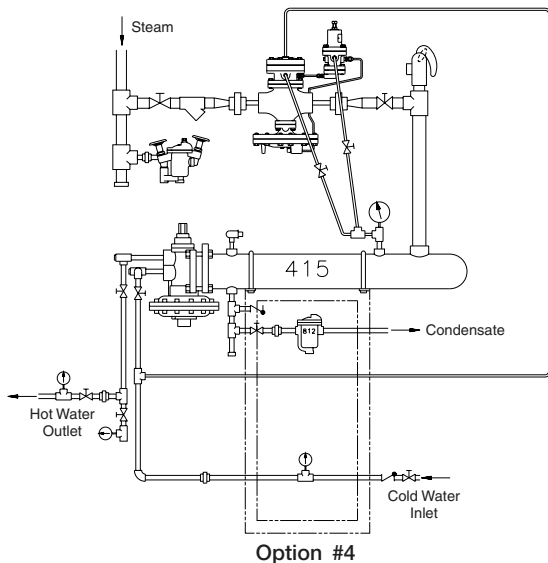

IMPORTANT UNIT START-UP AND SHUTDOWN PROCEDURES

Its important to remember that water pressure must ALWAYS be greater than steam pressure on the unit to avoid boiling the water in the tubes of the heat exchanger. When starting up a FLO-RITE-TEMP it is very important that the water supply is turned on to the unit before any steam is turned on. Once the unit is up and running, the inlet water valve should never be closed unless the steam is turned off first. When shutting down a unit you should always first shut off the steam and then allow water to run through the unit until it has cooled and completely condensed all remaining steam in the heat exchanger before closing off the supply water to the unit.

ADJUSTING PROCEDURES

All models of FLO-RITE-TEMP's have two settings which need to be made on initial start-up. One setting must be made at low flow while the other is made at high flows.

IMPORTANT: Once the low and high flow adjustments have been made, the unit generally need not be adjusted again unless your operating conditions change or a different set point is desired. A significant drop in temperature output or capacity is an indication of a bad diaphragm or that the tube bundle needs to be cleaned. Do not readjust the valve unless isolation of the unit from the system and running water to drain produces poor temperature control. If capacity is minimal, check the diaphragm or clean the bundle but do not readjust the control valve.

START-UP AND ADJUSTING PROCEDURE FOR MODEL 415

1. Before turning on the steam to the FLO-RITE-TEMP, begin by opening the water supply valve to the unit and checking for water leaks at the unit or any of the associated piping.
2. If the unit is connected to a system which has a recirculation loop and pump, be sure the pump is turned off and the isolation valve on the leg of piping going from the diverting valve back to the inlet of the FLO-RITE-TEMP is closed (this is the isolation valve downstream of port "B" of the thermostatic diverting valve). (See Fig. 3-1)
3. Close the isolation valve on the hot water outlet of the unit and open full and close several times the throttling bypass valve to drain to purge all the air from the FLO-RITE-TEMP. (See Fig. 3-1B). This process also primes the units lower diaphragm area with water. **Failure to do this prior to initial adjustment can result in inaccurate settings and poor results.**

4. Throttle the bypass valve to drain so that a constant 3 gpm of flow may pass to drain.
5. Slowly open steam valve or adjust the pressure reducing valve to allow 2 - 15 psig of steam pressure on the unit

(CAUTION: always make sure there is water pressure on the unit before adding steam. Failure to do this will cause severe hammering of the unit and possible damage).

6. Make sure that the steam trap draining the unit is functioning properly and allow the entire unit to come up to temperature for at least three to five minutes while passing the 3 gpm of water flow to drain before beginning the adjustment of the unit.
7. Locate the low and high flow adjustments on top of the mixing valve hidden under the hex bonnet (see Fig. 7-1). Before beginning adjustments, check to make sure the high flow adjustment is fully open. To do this start by pressing down on the high flow adjustment when water pressure is present on the unit and there is no water flow through the unit. This should only depress about 1/8". If it pushes in further, turn the adjustment stem counter clockwise to open. Check every turn until there is only 1/8" travel to the high flow stem when pushed down (Note: with water pressure on the unit the stem should pop back up after depressing it). If the high flow adjustment stem will not depress at all the valve is opened too far and you must turn the adjustment clockwise until there is 1/8" travel downward to the stem.
8. With the unit now isolated from the hot water system and all flow of water being directed to drain at 3 gpm, let the temperature stabilize.
9. Monitor the outlet temperature on the gauge located in the bypass to drain (see Fig. 3-1B). Place an adjustable wrench on the flats of the low flow adjustment (see Fig. 7-1).

Turning clockwise raises the discharge temperature and counter-clockwise lowers the discharge temperature. Make the appropriate adjustment to achieve the desired set point. For example if a set point of 140 °F is desired and the temperature reading is 155 °F, you must turn the low flow adjustment counter-clockwise to lower the set point temperature from 155 °F down to 140 °F.

(IMPORTANT - When making the low flow adjustment the high flow adjustment shaft SHOULD rotate with the low flow adjustment. If it does not do so, you will have to turn it by hand while making the low flow adjustment). Allow the unit to stabilize to be sure that the unit will remain at the desired set point. The low flow is now adjusted and should not be readjusted.

10. To make the high flow adjustment, SLOWLY increase the flow of water through the unit to drain while monitoring the outlet thermometer. When the outlet temperature has dropped by approximately 10 °F below set point for a Model 415E, make your high flow adjustment while maintaining that flow.
 11. Place a small screw driver or center punch through the hole in the high flow adjustment stem (see Fig. 7-1) and turn it in a clockwise direction. This will start to close the valve restricting the cooling water and cause the outlet water temperature of the unit to rise. Continue until the outlet temperature is back up to your required set point.
- (IMPORTANT - When making the high flow adjustment the low flow adjustment SHOULD NOT rotate with the high flow adjustment. If it does, you will have to hold it stationary while making your high flow adjustment).**
12. The unit is now adjusted.

(IMPORTANT - If for any reason you must readjust the unit, you will first have to return the high flow adjustment back to its full up position as stated in point #7).

START-UP AND ADJUSTING PROCEDURE FOR MODEL 535EP, 665SEP and 8120

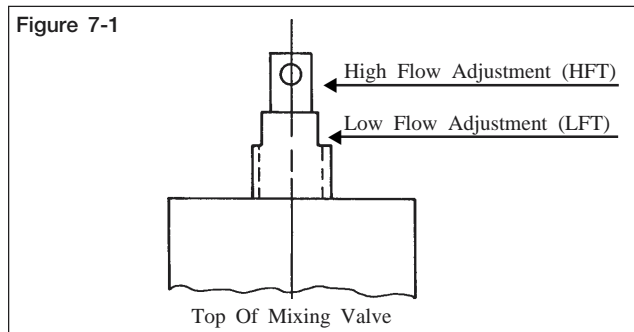

Follow all the steps 1-6 as stated in the adjustment procedures of the model 415.

7. Locate the low flow temperature adjustment (LFT) and the high flow temperature adjustment (HFT) on top of the mixing valve hidden under the hex bonnet (See Fig. 7-1). Before beginning adjustments, check to make sure the LFT is fully closed. To do this, turn the LFT clockwise until it stops. Also make sure the HFT is fully open. To do this start by pressing down on the HFT when water pressure is present on the unit and there is no water flow through the unit. The HFT should only depress about 1/8". If it pushes in further, turn the HFT stem counter clockwise to open. Check every turn until there is only 1/8" travel to the HFT when pushed

down (Note: with water pressure on the unit the stem should pop back up after depressing it). If the HFT stem will not depress at all the valve is opened too far and you must turn the adjustment clockwise until there is 1/8" travel downward to the stem.

8. With the unit now isolated from the hot water system and all flow of water being directed to drain, slowly increase the water demand to approximately 3/4 of the maximum capacity according to the capacity chart on page 13. When starting a cold system, you should take at least 2 to 3 minutes to slowly increase to this demand. This will allow time for the steam piping feeding the unit to come up to temperature, pressure and purge itself of excess condensate.
9. Place a small screwdriver or center punch through the hole in the HFT adjustment and slowly turn the HFT to change the temperature to the desired set point. Close (clockwise) the HFT to raise the outlet water temperature. Allow adequate time for the water temperature to stabilize. This could take several minutes if the piping is cold and the measurement point is far from the unit.

(IMPORTANT: When making the HFT adjustment, the LFT adjustment SHOULD NOT rotate with the HFT adjustment. If it does, you will have to hold it stationary while making your HFT adjustment).

10. Lower the water flow rate to 3 gpm. The LFT adjustment is currently fully closed (see step 8). Slowly open (counterclockwise) the LFT to lower the outlet water temperature to the desired set point. Allow adequate time for the temperature to stabilize. This will take longer since the flow rate is so small.

(IMPORTANT: When making the LFT adjustment, the HFT adjustment shaft SHOULD rotate with the LFT adjustment. If it does not do so, you will have to turn it by hand while making the LFT adjustment).

11. Recheck the outlet water temperature at 3/4 of the maximum demand it will see. Adjust if necessary. Opening the HFT (counterclockwise) will lower the temperature and closing the HFT (clockwise) will raise the temperature. **Note:** You may want to fine tune the HFT adjustments during normal operation of the unit at heavy demand. If outlet temperature is slightly low, turn HFT clockwise to raise it. This should only be done during the initial service of the unit or when the unit has been cleaned. Never attempt to re-adjust the unit with a dirty tube bundle - always clean tube bundle first. The unit is now adjusted.

(IMPORTANT: If, for any reason, you must readjust the unit, you will first have to return the LFT adjustment to the fully closed position as stated in step 8).

CAUTION

When putting a heavy load on the heat exchanger, watch the steam pressure gauge. This pressure should not be permitted to fall below 2 psig. If it does and severe water hammer develops, reduce the load by closing some of the faucets or shut the system down. When steam pressure drops under heavy load and hammering occurs, not enough steam is getting to the unit. This can be a result of an undersized reducing valve, lack of boiler capacity or restrictive steam lines. Hammering can also be caused by a loss of water pressure where the water pressure in the unit falls below the pressure of steam. This condition is usually caused by improper shutdown of the unit or someone closing the inlet water valve with the steam pressure still on the unit.

FLO-RITE-TEMP

Recirculation System Piping and Operation

Because of its relatively small size and compactness, the FLO-RITE-TEMP can easily be installed close to the point of water use eliminating the need for a recirculation system.

In applications where water heaters are located in basements or utility rooms and feed an entire building or wing a recirculation system or loop must be utilized to assure instantaneous hot water to all usage points.

The recirculation system is made up of several different components designed to work together to maintain the temperature of the water in the loop at times of low or no flow.

Recirculation pump - This is a constant GPM pump that runs continuously regardless of the hot water demand from the loop. Its function is to continually recirculate the water in the loop in order to maintain the temperature during low or no flow conditions. As a rule of thumb, the capacity of the pump should be approximately 10 to 15 percent of the maximum capacity of the FLO-RITE-TEMP and be able to overcome any head found in the loop. The recirculation pump however, may be larger than 15 percent. But when a larger pump is used, a full line size bypass with a globe valve must be piped to divert most of the flow around the thermostatic capsule.

Three-way Thermostatic Capsule - This device has a set point roughly 20 degrees below the set point of the FLO-RITE-TEMP and will maintain the temperature in the loop between the set point of the capsule and the set point of the FLO-RITE-TEMP. The capsule senses the temperature of the recirculated water and compares it with its pre-set temperature. If the temperature in the loop drops below the capsule's set point because of radiation loss from the piping and no hot water demand from the loop, then the capsule begins to divert some of the loop's flow to the inlet of the FLO-RITE-TEMP (ports A to B) for reheating. This diversion will bring the temperature of the loop back up to its required temperature. Once the temperature in the loop is over the capsule's set point all flow from the recirculation pump now goes straight through the capsule (ports A to C) and the return water is fed back to the hot water supply line. To regulate flow to the capsule, a balancing/bypass line with globe valve is required.

This diverting recirculating system eliminates the need for aquastats and any electrical wiring. It is a self contained, self regulating system that controls the temperature of the water in the loop during low or no hot water demand situations. When there is a demand for hot water the temperature of the water introduced into the system is instantly controlled by the FLO-RITE-TEMP feed forward mode of operation.

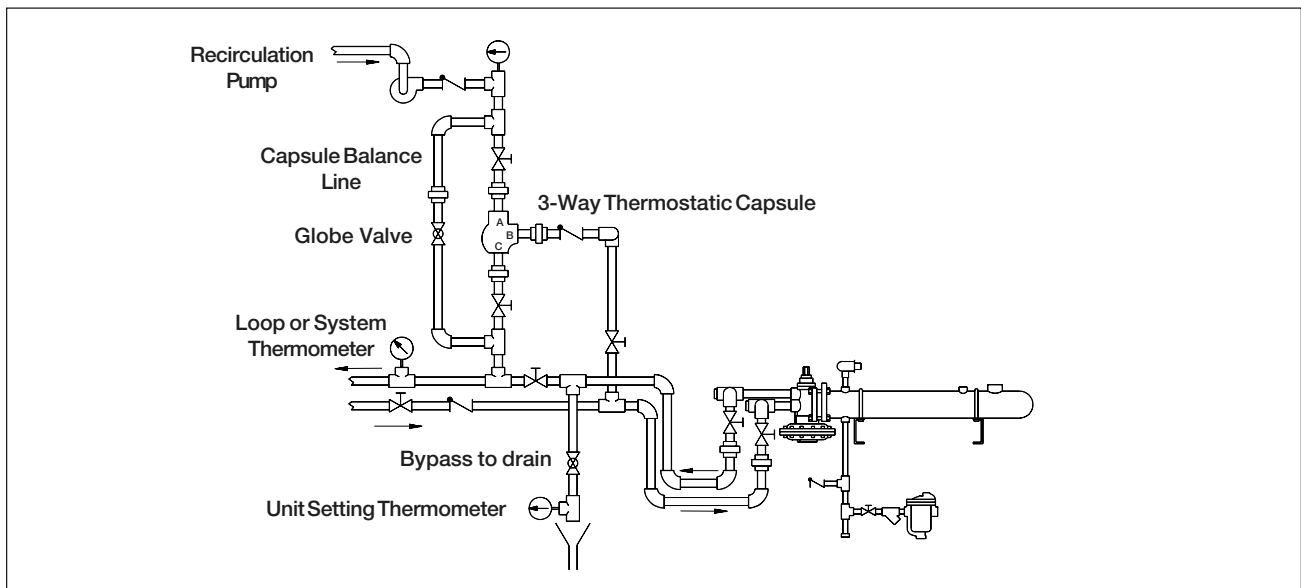

Fig. 9-1

FLO-RITE-TEMP-Accumulation System

For peak load conditions or to avoid large intermittent steam demands

The FLO-RITE-TEMP water heater accumulation system is designed to provide a specified volume of accumulated hot water for short duration peak loads or when steam is in short supply and a recovery time can be tolerated. During periods of low or no demand, the water in the accumulator tank is heated to the set point temperature by the FLO-RITE-TEMP water heater.

An accumulator or large storage tank is installed in series with the FLO-RITE-TEMP water heater. Cold water is piped to the inlet of the water heater and into the bottom of the accumulator tank. Hot water flows from the FLO-RITE-TEMP directly to the accumulator tank through a pump that is controlled by an aquastat. When the pump is off the flow goes to the accumulator via a bypass around the pump. This would occur when there is hot water demand and the temperature in the tank is at set point.

When the system is started the water in the accumulator tank is cold which causes the aquastat to turn the pump on. Water flows out of the bottom of the tank to the inlet of the FLO-RITE-TEMP. The water continues this cycle until the aquastat in the tank senses the appropriate temperature. At that time the pump shuts off and the water is ready for use. The globe valve on the bottom of the accumulator tank should be adjusted at full system demand so that a pressure differential of approximately 8 psi is read across the FLO-RITE-TEMP.

In operation, hot water is drawn off the top of the tank at the same time as cold water enters from the bottom and hot water from the FLO-RITE-TEMP enters the tank from the side. When the peak load stops and the aquastat senses the cooler water in the tank, the pump starts and the heating process begins another cycle.

A bypass line from the heater to the hot water demand is normally kept closed. When the accumulator tank requires maintenance this bypass allows the tank to be isolated, with hot water being supplied by the FLO-RITE-TEMP only.

Advantages of the accumulation system are:

- Accumulation tank temperatures are restored over a period of time avoiding large intermittent steam demands.
- Providing the FLO-RITE-TEMP's safety features to the entire system.
- Providing accurate hot water temperature control.
- Providing a back up alternative during tank maintenance.
- To allow accumulator tanks to be relatively small in size because hot water demand is supplemented by the FLO-RITE-TEMP.

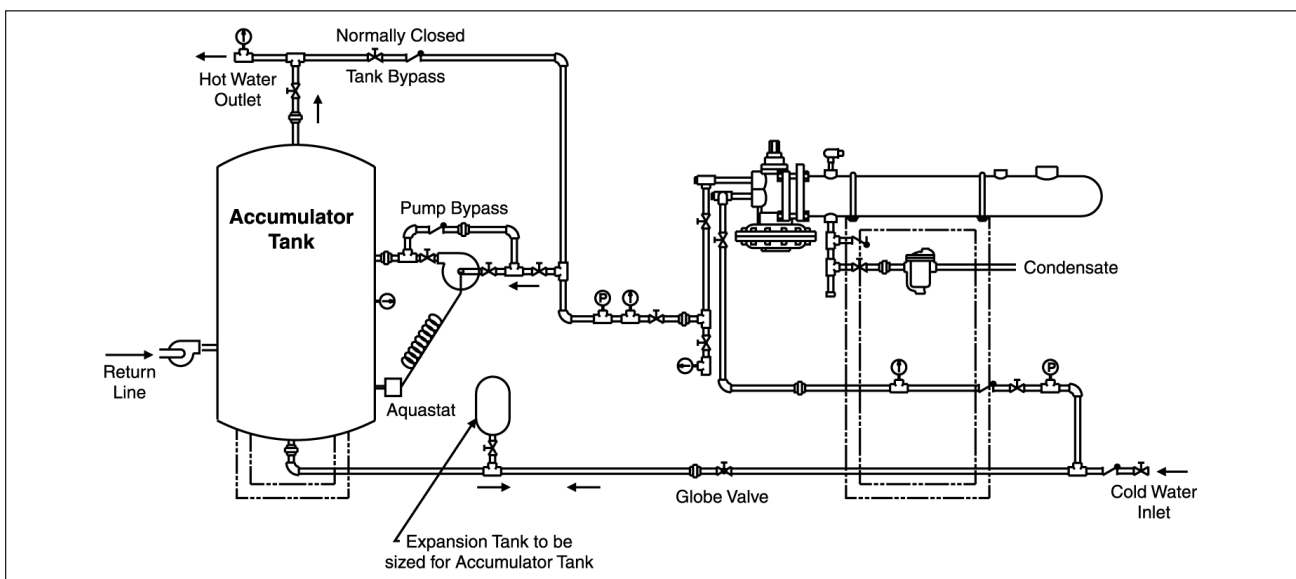

Fig. 10-1

Flo-Rite-Temp Tempered Water Systems

For Safety Shower/Eye Wash Stations

The problem which faces many companies today is how to safely warm water to be used effectively in a drench shower or safety shower situation.

Storage tank units can run out of warm water causing people to go into possible shock due to cold water exposure or to end the shower before proper flushing has taken place. Also, because the water in the tank is only heated to a temperature range of 65 to 95 degrees F. there is the potential and risk of legionella bacteria forming inside of the tank. Lastly, tank systems are feedback systems which can cause severe overheating of the water when thermostatic elements fail causing personal injury.

The solution is to use the Armstrong Flo-Rite-Temp tankless instantaneous feedforward water heater in series with a self-contained fail safe thermostatic mixing valve.

How The System Works

The system, when piped as shown in the drawing, will provide a safe, continuous and dependable source of accurately controlled warm water.

Incoming cold water is heated between 120 to 130 degrees F by the Flo-Rite-Temp. (The unit is set to provide a constant supply of hot water at an

adjusted set point within this temperature range, usually the lowest set point of 120° degrees is used). The 120°F water can be piped to the Rada Z358 thermostatic mixing valve which will blend cold water with the 120°F water to make the tepid water for the safety shower/eye wash station. The Rada Z358 valve is equipped to allow cold water to the showerhead in the event of hot water failure.

The Rada Z358 Mixing Valve (see Bulletin ALIB-Z358-20) properly proportions the hot and cold incoming water to obtain a preset delivery temperature to the drench shower head. Demand induced changes are sensed and automatically compensated for by the valve so that shower output temperature remains constant. A recirculation system may also be incorporated in this system and is especially recommended in applications where shower lines are exposed to the cold air or shower heads are a distance from the heater.

Feedforward control in the water heater eliminates the danger of thermostatic element failure and overheating typical in storage tank feedback systems. Because there is no storage tank, there is no danger of legionella forming in the stored warm water. All water is heated **instantaneously on the spot**, there is no shortage of heated water or shower time limits.

Option 1: Water recirculation when heater is servicing a long run to the shower head, more than one shower head, or piping is exposed to cold ambient temperatures

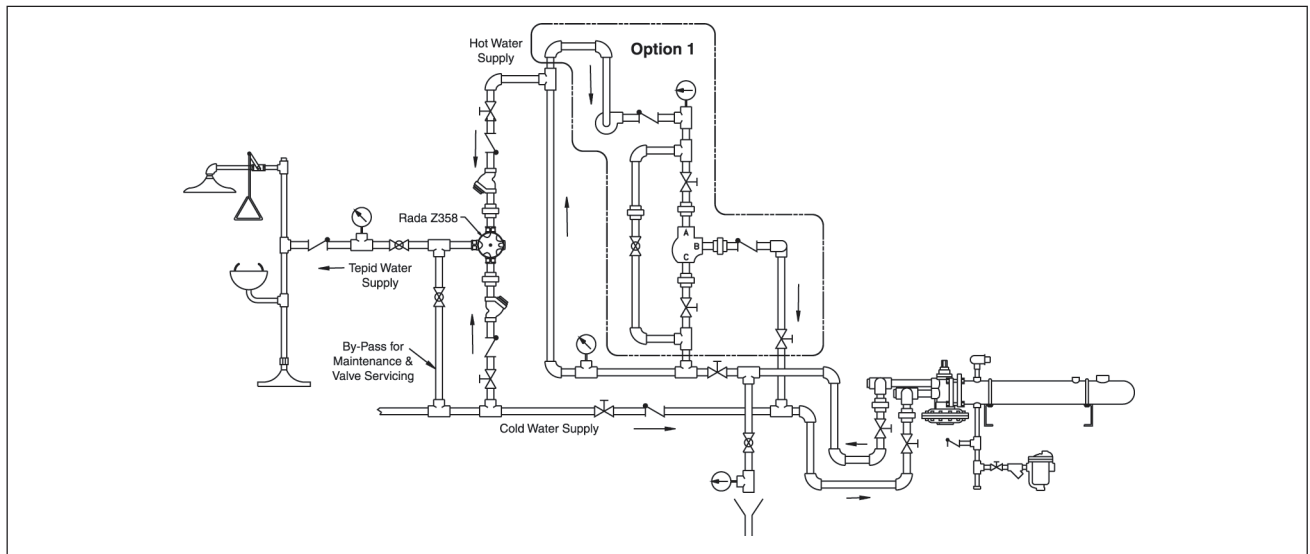
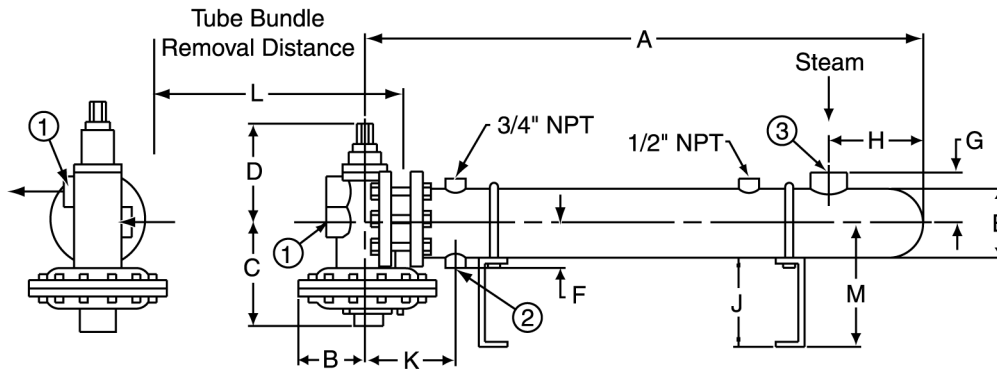

Fig. 11-1

Single Wall and Double Wall Profile



Model 415 and 535 Profile Shown (665 and 8120 valve shows that connections for water inlet and outlet are on opposite sides of the valve body).

Fig. 12-1

Table 12-1. Dimensions and Weights

Model	Dimensions												Connections			Wt.		
		A	B	C	D	E	F	G	H	J	K	L	M	1	2			3
415	in	54	4-1/2	7-1/2	7	4-1/2	3-1/2	3-1/2	7	5	6-1/4	50	7-1/2	1" NPT	3/4" NPT	2" NPT	lb	133
	mm	1372	114	190	178	114	89	89	178	127	159	1270	190	25	20	50	kg	60
535	in	67-1/2	5-1/4	8-5/8	9	5-9/16	4	4-1/2	7-7/8	6	7-1/2	62	9	1-1/2" NPT	1" NPT	2-1/2" NPT	lb	235
	mm	1715	133	219	229	141	102	114	200	152	191	1575	229	40	25	65	kg	107
665	in	82	5-3/4	10-3/8	10-3/8	6-5/8	4-3/4	5-1/2	9-1/4	7-1/2	8-3/4	74	11	2" NPT	1-1/4" NPT	3" NPT	lb	358
	mm	2083	146	264	264	168	121	140	235	190	222	1880	280	50	32	80	kg	162
8120	in	85	5-3/4	11-3/4	12	8-5/8	6-1/8	8-7/8	9-1/2	8	9-1/2	74	12-3/8	3" NPT	2" NPT	4" 150# ANSI	lb	585
	mm	2159	146	299	305	219	156	225	241	203	241	1880	314	80	50	100	kg	265
415DW	in	76-1/8	4-1/2	7-1/2	7	4-1/2	3-3/8	3-3/4	10-1/2	5	6-7/8	75	7-1/2	1" NPT	3/4" NPT	2" NPT	lb	199
	mm	1934	114	190	178	114	86	95	267	127	175	1905	190	25	20	50	kg	90
535DW	in	77-3/8	5-1/4	8-5/8	9	5-9/16	4	4-1/4	11-1/2	6	8-1/8	75	9	1-1/2" NPT	1" NPT	2-1/2" NPT	lb	270
	mm	1965	133	219	229	141	102	108	292	152	206	1905	229	40	25	65	kg	122
665DW	in	90-5/8	5-3/4	10-3/8	10-3/8	6-5/8	4-3/4	5	11-3/4	7-1/2	9-3/4	87	11	2" NPT	1-1/4" NPT	3" NPT	lb	444
	mm	2302	146	264	264	168	121	127	298	191	248	2210	280	50	32	80	kg	201
8120DW	in	79-7/8	5-3/4	11-3/4	12	8-5/8	6	8-3/4	12-5/8	8	11-5/8	75	12-3/8	3" NPT	2" NPT	4" 150# ANSI	lb	665
	mm	2029	146	298	305	219	152	222	321	203	295	1905	314	80	50	100	kg	302

Table 12-2 Materials

	Body	Valve	Valve Seats	Diaphragm	Heat Exchanger Shell	Heat Exchanger Tubes	Tube Sheets**	Tube Bundle End Cap
Single Wall		(415) 303 Stainless Steel with Teflon Inserts	(415/535) 303 Stainless Steel	Viton® GF Reinforced with Nomex® Fiber	Carbon Steel ASME "U" Stamped	5/8" 16 BWG Admiralty Brass	Brass	Brass
		(535/665/8120) Brass	(665/8120) Brass					
Double Wall	Bronze	(415DW) 303 SS with Teflon Inserts	(415DW/535DW) 303 SS	Viton® GF Reinforced with Nomex® Fiber	Carbon Steel ASME "U" Stamped	5/8" Copper Inner Tube 3/4" I.D. Grooved Copper Outer Tube	Steam Side Steel/Water Side Brass	N/A
		535DW/665DW/8120DW Brass	(665DW/8120DW) Brass					

Note: ** There is an open vent to atmosphere between the tube sheets to detect tube failure.

Table 12-3. Specifications

Application	Steam Supply Pressure	Water Supply Pressure	Maximum Water Pressure Drop
Steam to Water	2 - 15 psig (0.14 - 1.0 bar)	20 - 125 psig (1.4 - 8.5 bar)	10 psig (0.7 bar)

FLO-RITE-TEMP

CAPACITIES AND STEAM LOADS

Table 13-1

Inlet Temp. °F	Set Temp. °F	Standard								Inlet Temp. °C	Set Temp. °C	Standard								Model
		Hot Water Capacities*				Steam Capacities						Hot Water Capacities*				Steam Capacities				
		Steam Pressure				Steam Pressure						Steam Pressure				Steam Pressure				
		psig	psig	psig	psig	psig	psig	psig	psig			bar	bar	bar	bar	bar	bar	bar	bar	
		2	5	10	15	2	5	10	15			0.14	0.35	0.7	1	0.14	0.35	0.7	1	
lb/hr	lb/hr	lb/hr	lb/hr	lb/hr	lb/hr	lb/hr	lb/hr	m³/h	m³/h	m³/h	m³/h	kg/hr	kg/hr	kg/hr	kg/hr					
40	120	17	18	20	20	714	767	839	901	4	49	3.8	4.1	4.5	4.5	323	347	379	407	415
		37	40	43	45	1543	1657	1814	1946			8.4	9.1	9.8	10.2	697	749	820	880	535
		69	74	80	80	2855	3067	3356	3601			15.7	16.8	18.2	18.2	1290	1386	1517	1628	665
		142	145	145	145	5680	6160	6760	7160			32.2	32.9	32.9	32.9	2576	2794	3066	3248	8120
	130	15	16	17	18	681	734	807	868		54	3.4	3.6	3.8	4.1	308	332	365	392	415
		32	34	37	39	1472	1587	1743	1876			7.3	7.7	8.4	8.8	665	717	788	848	535
		58	63	68	73	2723	2936	3226	3472			13.2	14.3	15.4	16.6	1230	1327	1458	1569	665
		112	122	136	145	5040	5490	6120	6705			25.4	27.7	30.9	32.9	2286	2490	2776	3041	8120
	140	12	13	15	16	646	700	773	835		60	2.7	3.0	3.4	3.6	292	316	349	377	415
		27	29	32	34	1397	1513	1671	1804			6.1	6.6	7.3	7.7	631	684	755	815	535
		50	54	59	63	2585	2799	3091	3338			11.3	12.2	13.3	14.3	1168	1265	1397	1509	665
		88	97	109	120	4400	4850	5450	6000			20.0	22.0	24.7	27.2	1996	2200	2472	2722	8120
	160	9	10	11	12	572	627	702	765		71	2.0	2.3	2.5	2.7	259	283	317	346	415
		20	22	24	26	1235	1355	1517	1652			4.5	5.0	5.5	5.9	558	612	686	747	535
		37	40	45	48	2286	2508	2806	3057			8.4	9.1	10.2	10.9	1033	1134	1268	1382	665
		69	83	89	95	4140	4980	5340	5700			15.6	18.8	20.0	21.6	1878	2259	2422	2585	8120
	180	5	5	6	7	344	386	441	487		82	1.1	1.1	1.4	1.6	156	175	200	221	415
		12	13	15	16	861	966	1104	1219			2.7	3.0	3.4	3.6	390	438	501	553	535
		23	26	29	32	1663	1866	2134	2355			5.2	5.9	6.6	7.3	754	846	968	1068	665
		43	47	52	59	3010	3290	3640	4130			9.7	10.7	11.8	13.4	1365	1492	1651	1873	8120
50	120	19	20	20	20	692	745	816	877	10	49	4.3	4.5	4.5	4.5	313	337	369	396	415
		41	44	45	45	1495	1609	1764	1896			9.3	10.0	10.2	10.2	676	727	797	857	535
		76	80	80	80	2767	2977	3264	3508			17.3	18.2	18.2	18.2	1251	1346	1475	1586	665
		145	145	145	145	5740	6090	6580	7035			32.2	32.2	32.2	32.2	2603	2762	2985	3191	8120
	130	16	17	19	20	660	712	785	846		54	3.6	3.8	4.3	4.5	298	322	355	382	415
		34	37	40	43	1425	1539	1695	1827			7.7	8.4	9.1	9.8	644	696	766	826	535
		64	68	75	80	2637	2848	3137	3381			14.5	15.4	17.0	18.2	1192	1287	1418	1528	665
		127	138	145	145	5080	5520	6120	6760			28.8	31.3	32.2	32.2	2304	2504	2776	3066	8120
	140	13	14	16	17	626	679	752	813		60	2.9	3.2	3.6	3.8	283	307	340	367	415
		29	31	34	37	1352	1467	1624	1756			6.6	7.0	7.7	8.4	611	663	734	794	535
		54	58	64	68	2502	2715	3005	3250			12.2	13.2	14.5	15.4	1131	1227	1358	1474	665
		99	108	121	134	4455	4860	5445	6030			22.5	24.5	27.5	30.4	2021	2204	2470	2735	8120
	160	10	11	12	13	553	608	682	744		71	2.3	2.5	2.7	3.0	250	275	308	336	415
		21	23	25	28	1194	1313	1473	1607			4.7	5.2	5.7	6.4	540	593	665	726	535
		39	42	47	51	2210	2429	2725	2974			8.9	9.5	10.7	11.6	999	1098	1232	1344	665
		76	90	95	102	4180	4950	5225	5610			17.2	20.4	21.6	23.1	1896	2245	2370	2545	8120
	180	7	6	6	7	332	373	428	473		82	1.1	1.4	1.4	1.6	151	169	194	214	415
		12	14	16	17	831	934	1071	1185			2.7	3.2	3.6	3.9	377	424	486	537	535
		24	27	30	33	1605	1805	2069	2289			5.4	6.1	6.8	7.5	728	819	938	1037	665
		49	55	63	72	3185	3575	4095	4680			11.1	12.5	14.3	16.3	1445	1622	1857	2123	8120
60	130	18	19	20	20	638	690	762	822	16	54	4.1	4.3	4.5	4.5	288	312	344	372	415
		38	41	45	45	1378	1491	1646	1777			8.7	9.3	10.2	10.2	623	674	744	803	535
		70	76	80	80	2550	2760	3046	3288			15.9	17.3	18.2	18.2	1152	1247	1377	1486	665
		145	145	145	145	5110	5565	6090	6510			32.2	32.2	32.2	32.2	2318	2524	2762	2953	8120
	140	15	16	17	19	605	658	729	790		60	3.4	3.6	3.8	4.3	273	297	330	357	415
		32	34	38	40	1307	1421	1576	1708			7.3	7.7	8.6	9.1	591	642	712	772	535
		58	63	69	75	2418	2629	2917	3160			13.2	14.3	15.7	17.0	1093	1188	1318	1428	665
		111	123	137	145	4440	4920	5480	6080			25.2	27.9	31.1	32.2	2014	2232	2486	2758	8120
	160	10	11	13	14	533	588	661	723		71	2.3	2.5	2.9	3.2	241	266	299	327	415
		22	24	27	30	1152	1270	1428	1561			5.0	5.5	6.1	6.8	521	574	645	703	535
		41	45	50	55	2132	2349	2642	2889			9.3	10.2	11.3	12.5	964	1062	1194	1306	665
		85	99	104	115	4250	4950	5200	5750			19.3	22.5	23.6	26.1	1928	2245	2359	2608	8120
	180	5	6	7	7	320	360	414	459		82	1.1	1.4	1.6	1.6	145	163	188	208	415
		13	14	16	18	800	902	1037	1150			3.0	3.2	3.6	4.1	363	409	470	522	535
		25	28	32	35	1546	1743	2004	2221			5.7	6.4	7.3	7.9	701	791	909	1007	665
		59	67	80	90	3540	4020	4800	5400			13.4	15.2	18.1	20.4	1606	1823	2177	2449	8120

*Units may be piped in parallel when desired capacities exceed that of a single unit.

Notes: Minimum water temperature increase is 60°F (33°C). Consult factory if less than 60°F (33°C) increase is required or a set temperature of below 120°F (49°C) is required. See Armstrongs All Products Catalog 326 for proper pressure reducing valve selection.

TROUBLESHOOTING GUIDE

Table 14-1

Problem	Causes	Solutions
Only cold water comes out of the unit.	The steam is not turned on to the unit.	Open steam valve to the unit.
	The water tubes in the heat exchanger are plugged.	See Clean-In-Place operating instructions or remove tube bundle and clean.
	The differential pressure sensing diaphragm is ruptured.	Replace the diaphragm.
	The mixing valve is not properly adjusted.	Adjust the unit according to the instructions.
Only warm water comes out of the unit.	The steam pressure is too low.	Increase steam pressure (2 - 15 psig).
	Air has accumulated in the shell of the heat exchanger.	Install a thermostatic air vent on the shell.
	The flow is above the rated capacity of the unit.	Make sure unit is sized properly.
	The tubes in the heat exchanger are scaled.	See Clean-In-Place operating instructions or remove tube bundle and clean.
	The mixing valve is not properly adjusted.	Adjust the unit according to the instructions.
Extreme hot water comes out of the unit.	The steam pressure is too high.	Decrease steam pressure (2 - 15 psig).
	Recirculated water is continually diverting through the Flo-Rite-Temp.	Check diverting valve for a stuck or failed thermal capsule.
	The steam is superheated.	Pipe to saturated steam.
	The mixing valve is not properly adjusted.	Adjust the unit according to the instructions.
No water comes out of the unit.	The inlet valve on the water supply is closed.	Open valve.
	There is no demand for hot water.	Wait till demand is present then re-check.
The unit hammers and bangs during operation.	The shell of the heat exchanger is not properly drained.	Make sure steam trap is working and properly installed. Make sure shell is level to floor. Do not elevate condensate if pressure is low.
	The steam pressure has dropped or a vacuum has formed.	Increase pressure and install vacuum breaker at shell drain (Figure 1-1).
	The water pressure had dropped below that of the steam pressure and steam is forming inside of the water tubes.	Install a pressure switch on water inlet to shut off steam on a drop in water pressure.

DISASSEMBLY

Control Valve - All maintenance on the valve should be done by a factory trained product specialist with the exception of replacing the pressure sensing diaphragm. To replace the diaphragm remove all nuts and bolts from the bottom cover. After removing the bottom cover, remove the lock nuts from the bottom of the valve shaft. You will need to hold the platter to prevent the assembly from spinning, or hold the stem with large a slotted screw driver in the slot at the bottom of the stem. After removing the nuts, slide the platter off, then the old diaphragm, being careful not to lose the brass washer above the diaphragm. To reassemble follow the reverse order. Make sure when tightening the cover bolts that you use a criss-cross pattern.

Single Wall Heat Exchanger - To remove the tube bundle for cleaning. Simply unbolt the mixing valve from the shell and move it out of the way. The tube bundle can be pulled out from the valve end (see Table 12-1 for clearance dimensions). Once the tube bundle is out of the shell, unbolt the end cap on the floating head end and remove to provide straight through cleaning. Reassemble in the reverse order (On the Model 665 dual stem unit when reassembling the tube bundle, make sure that the "TOP" indicator stamped on the cover and both ends of the tube bundle line up and bundle is reinstalled in the shell with both "TOP" indicators facing up). New gaskets will be required for this procedure. (Order heat exchanger gasket kit for model number)

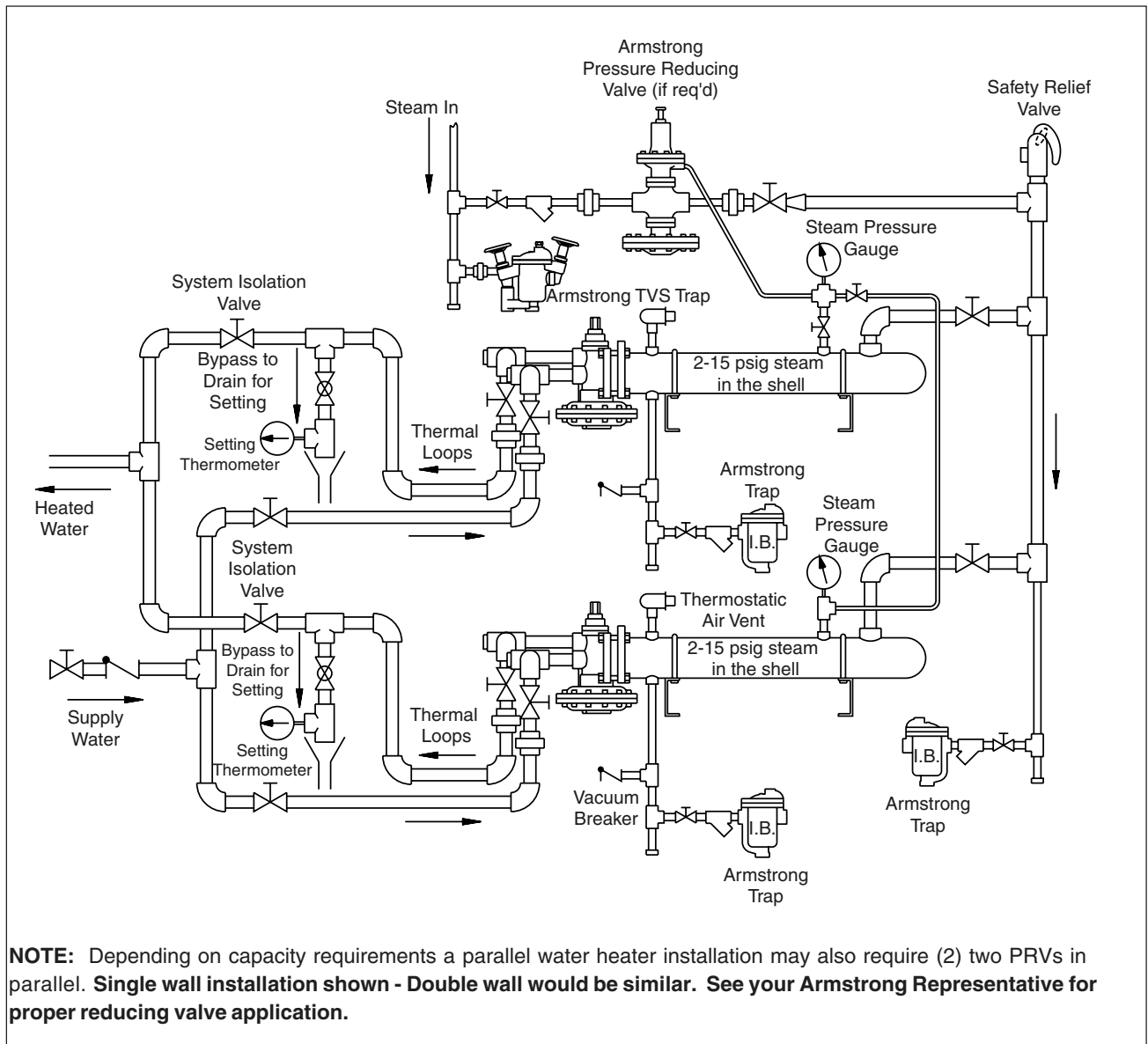

Fig. 15-1

Clean-In-Place Operating Instructions

When there is a noticeable drop in the Flo-Rite-Temp's — hot water capacity, temperature, or an increased water pressure drop across the unit — tube bundle scale removal should be considered using the commercially available product called RITE-Qwik*.

Tube bundle scale removal can be accomplished as follows:

- Step 1** - Shut off steam supply valve #1 to the Flo-Rite-Temp.
- Step 2** - While the water pressure is still ON and the steam is OFF, run the Flo-Rite-Temp for (10) ten minutes or until the outside of the unit is cool to the touch.
- Step 3** - Shut the water inlet valve #4 OFF and water outlet valve #5 OFF; open cleaning connection outlet #7. Connect air hose with regulator to valve #9. Turn air on slowly to approximately 5 psi. Increase to maximum of 25 psi. Leave air pressure on until water stops coming out of connection #7. Turn air (valve #9) off. Open cleaning connection inlet #8 and remove the pop-off valve or inlet pipe plug #6 from the lower diaphragm cover of the control valve. Let the remaining water drain by gravity from the Flo-Rite-Temp.
- Step 4** - After all the water has been drained, reinstall the pop-off valve or pipe plug #6 into the lower diaphragm cover of the control valve.
- Step 5** - With hose valve closed connect return hose A of the Clean-in-Place to the outlet cleaning connection #7 of the Flo-Rite-Temp.
- Step 6** - With hose valve closed connect discharge hose B of the Clean-in-Place to the inlet cleaning connection #8 of the Flo-Rite-Temp.
- Step 7** - Start pump. Open ball valve of discharge hose B of the Clean-in-Place.
- Step 8** - Slowly open the ball valve on return hose A and watch for foaming in the tank.
- Step 9** - Clean-in-Place is now circulating cleaning solution through the Flo-Rite-Temp. Periodically check the solution to see if it has changed color or quit fizzing. If the cleaning

solution has stopped fizzing and has not changed color, the Flo-Rite-Temp is clean. You may save the remaining unspent solution for your next job. If the solution quits fizzing and the color has changed, add new cleaning solution. Continue circulating in the same manner as above. **Do not exceed a maximum circulation time of (3) three hours.**

- Step 10** - Shut-off pump. Close discharge hose valve B on Clean-in-Place. Open air (valve #9). Turn air on slowly to approximately 5 psi. Increase as Clean-in-Place fluid returns to tank. **(Maximum air pressure 25 psi.)**
- Step 11** - Leave air blow for approximately 3-5 minutes. This should return most of the fluid to the tank. Close both hose valves.
- Step 12** - Disconnect return hose A from the Flo-Rite-Temp outlet cleaning connection #7 and discharge hose B from the inlet cleaning connection #8. Also remove the pop-off valve or pipe plug #6 from the lower diaphragm cover of the control valve. Let the cleaning solution drain by gravity from the Flo-Rite-Temp.
- Step 13** - Close valve #2 going into the system and open valve #3 going to the drain.
- Step 14** - Open the water outlet valve #5 then open SLOWLY inlet water valve #4. Let the water run for (1) one minute before installing the pop-off valve or pipe plug #6 into the lower diaphragm cover of the control valve.
- Step 15** - After the pop-off valve or pipe plug #6 is installed, run water into the drain for (5) five minutes to flush out all of the cleaning solution. Throttle the outlet valve #3 open and closed to purge the air from under the diaphragm.
- Step 16** - After flushing the unit, close valve #3 and open the steam supply valve #1 SLOWLY and let the Flo-Rite-Temp heat up.
- Step 17** - Set the Flo-Rite-Temp as needed. (This step may not be necessary).
- Step 18** - Open valve #2 to the system and monitor the system until the temperature is back to normal.
- Step 19** - After use, flush the pump with water to remove the chemical to prevent seal deterioration.

Flo-Rite-Temp

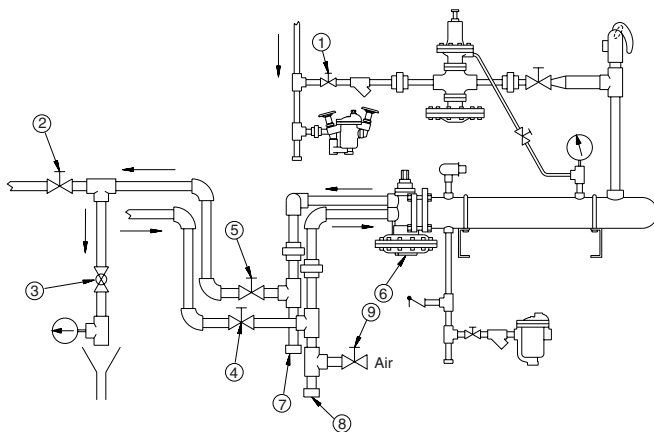

Clean-In-Place

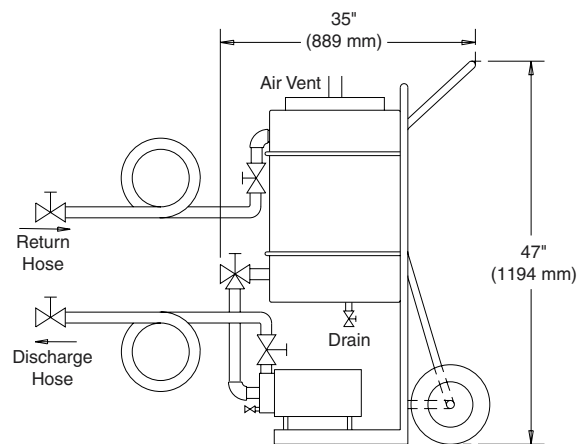

* RITE-QWIK is a non hazardous chemical cleaner which has been proven effective for removing deposits without harming the FLO-RITE-TEMP internally.

8120 Control Valve

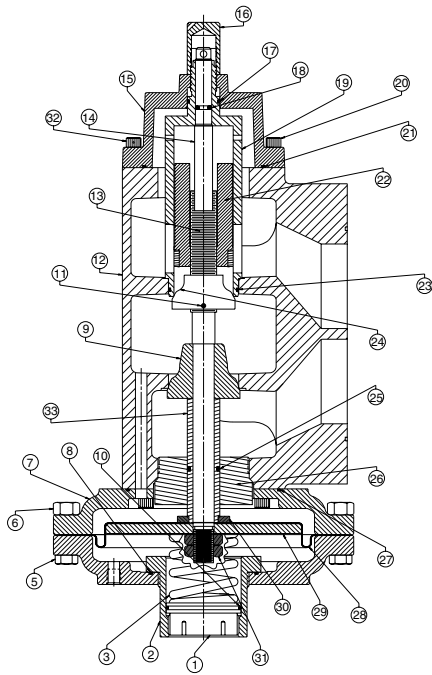

Listing of Parts	
Number	Description
1	Spring Adjustment
2	Spring Housing
3	Spring
4	Lower Diaphragm Cover
5	Diaphragm Bolt (12)
6	Diaphragm Nut (12)
7	Upper Diaphragm Cover
8	O-Ring 2-155
9	Lower Valve
10	O-Ring 2-147
11	Set Screw X2
12	Body
13	Stem
14	HFT Adjuster
15	Top Cap
16	Bonnet
17	O-Ring 2-121
18	O-Ring 2-111
19	Left Adjuster
20	Socket Cap Screw X13
21	O-Ring 2-157
22	Restrictor Assembly
23	O-Ring 2-144
24	Upper Valve Low Temperature
24	Upper Valve High Temperature
25	O-Ring 2-214
26	Stem Guide
27	O-Ring 2-162
28	Diaphragm
29	Diaphragm Supply Disc
30	Diaphragm Disc
31	Jam Nut (2)
32	Socket Cap Screw X1
33	Lower Valve Spacer

665 Control Valve

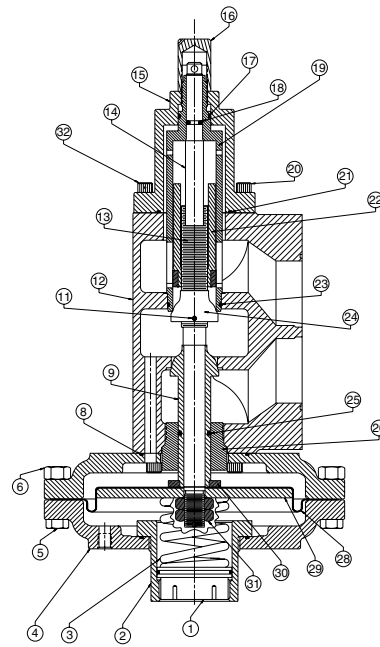

Listing of Parts	
Number	Description
1	Spring Adjustment
2	Spring Housing
3	Spring
4	Lower Diaphragm Cover
5	Diaphragm Bolt (12)
6	Diaphragm Nut (12)
7	Upper Diaphragm Cover
8	O-Ring 2-155 X2
9	Lower Valve
11	Set Screw X2
12	Body
13	Stem
14	HFT Adjuster
15	Top Cap
16	Bonnet
17	O-Ring 2-121
18	O-Ring 2-111
19	Left Adjuster
20	Socket Cap Screw X11
21	O-Ring 2-147 X2
22	Restrictor Assembly
23	O-Ring 2-134
24	Upper Valve Low Temperature
24	Upper Valve High Temperature
25	O-Ring 2-214
26	Stem Guide
28	Diaphragm
29	Diaphragm Supply Disc
30	Diaphragm Disc
31	Jam Nut (2)
32	Socket Cap Screw X1

535 Control Valve

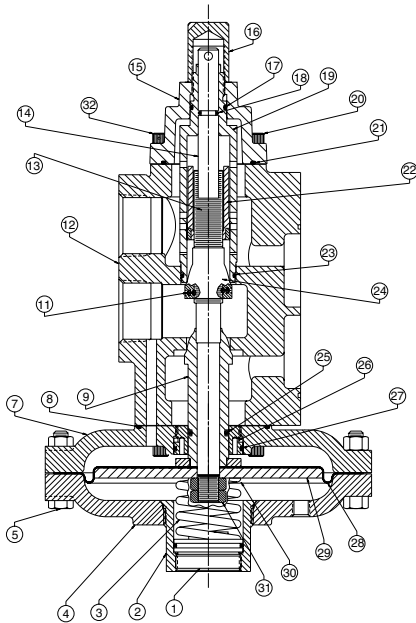

415 Control Valve

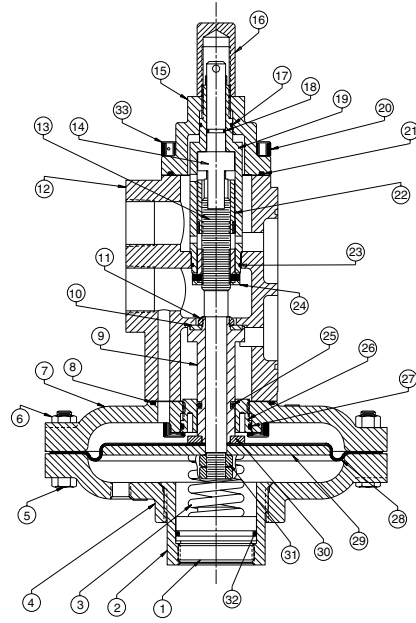

Listing of Parts	
Number	Description
1	Spring Adjustment
2	Spring Housing
3	Spring
4	Lower Diaphragm Cover
5	Diaphragm Bolt (12)
6	Diaphragm Nut (12)
7	Upper Diaphragm Cover
8	O-Ring 2-155
9	Lower Valve Low Temperature
9	Lower Valve High Temperature
11	Set Screw X2
12	Body
13	Stem
14	HFT Adjuster
15	Top Cap
16	Bonnet
17	O-Ring 2-119
18	O-Ring 2-111
19	Left Adjuster
20	Socket Cap Screw X11
21	O-Ring 2-147
22	Restrictor Assembly
23	O-Ring 2-128
24	Upper Valve Low Temperature
24	Upper Valve High Temperature
25	O-Ring 2-214
26	Retainer
27	O-Ring 2-135 X2
28	Diaphragm
29	Diaphragm Supply Disc
30	Diaphragm Disc
31	Jam Nut (2)
32	Socket Cap Screw X1

Listing of Parts	
Number	Description
1	Spring Adjustment
2	Spring Housing
3	Spring
4	Lower Diaphragm Cover
5	Diaphragm Bolt (12)
6	Diaphragm Nut (12)
7	Upper Diaphragm Cover
8	O-Ring 2-153
9	Lower Valve
10	Lower Valve Disc
11	Retainer Nut
12	Body
13	Stem
14	HFT Adjuster
15	Top Cap
16	Bonnet
17	O-Ring 2-018
18	O-Ring 2-012
19	Left Adjuster
20	Socket Cap Screw X7
21	O-Ring 2-138
22	Restrictor Assembly
23	O-Ring 2-025
24	Upper Valve Assembly
25	O-Ring 2-210
26	Retainer
27	O-Ring 2-131
28	Diaphragm
29	Diaphragm Supply Disc
30	Diaphragm Disc
31	Jam Nut (2)
32	O-Ring 2-135
33	Socket Cap Screw X1

Notes

Limited Warranty and Remedy

Armstrong-Yoshitake, Inc. ("Armstrong") warrants to the original user of those products supplied by it and used in the service and in the manner for which they are intended, that such products shall be free from defects in material and workmanship for a period of one (1) year from the date of installation, but not longer than 15 months from the date of shipment from the factory [unless a Special Warranty Period applies, as listed below]. This warranty does not extend to any product that has been subject to misuse, neglect, or alteration after shipment from the Armstrong factory. Except as may be expressly provided in a written agreement between Armstrong and the user, which is signed by both parties, Armstrong **DOES NOT MAKE ANY OTHER REPRESENTATIONS OR WARRANTIES, EXPRESS OR IMPLIED, INCLUDING, BUT NOT LIMITED TO, ANY IMPLIED WARRANTY OF MERCHANTABILITY OR ANY IMPLIED WARRANTY OF FITNESS FOR A PARTICULAR PURPOSE.** The sole and exclusive remedy with respect to the above limited warranty or with respect to any other claim relating to the products or to defects or any condition or use of the products supplied by Armstrong, however caused, and whether such claim is based upon warranty, contract, negligence, strict liability, or any other basis or theory, is limited to Armstrong's repair or replacement of the part or product, excluding any labor or any other cost to remove or install said part or product, or, at Armstrong's option, to repayment of the purchase price. As a condition of enforcing any rights or remedies relating to Armstrong products, notice of any warranty or other claim relating to the products must be given in writing to Armstrong: (i) within 30 days of last day of the applicable warranty period, or (ii) within 30 days of the date of the manifestation of the condition or occurrence giving rise to the claim, whichever is earlier. **IN NO EVENT SHALL ARMSTRONG BE LIABLE FOR SPECIAL, DIRECT, INDIRECT, INCIDENTAL OR CONSEQUENTIAL DAMAGES, INCLUDING, BUT NOT LIMITED TO, LOSS OF USE OR PROFITS OR INTERRUPTION OF BUSINESS.** The Limited Warranty and Remedy terms herein apply notwithstanding any contrary terms in any purchase order or form submitted or issued by any user, purchaser, or third party and all such contrary terms shall be deemed rejected by Armstrong.

Special Warranty Periods are as follows:

Flo-Rite-Temp Instantaneous Water Heater—The tube bundle shall have a 10-year guarantee against failure caused by materials or workmanship provided by Armstrong but not against gasket failure or damage caused by corrosion, water hammer or lack of proper cleaning.

Flo-Rite-Temp Packaged Instantaneous Water Heater—

Two (2) years from the date of installation, but not longer than 27 months from the date of shipment.

Flo-Direct Gas Fired Water Heater—The stainless steel structure and stainless steel internals shall have a 5-year guarantee against failure caused by materials or workmanship provided by Armstrong. Provided only clean potable water is heated.

Installation Date: _____

Installing Contractor: _____

Service Dates: _____



Armstrong Hot Water Group

221 Armstrong Blvd., P.O. Box 408, Three Rivers, Michigan 49093 - USA Ph: (269) 279-3600 Fax: (269) 273-8656

www.armstrong-intl.com