



# Rada® Single Point & Zoned/Group Control Systems

## Rada 50

Rada Thermostatic Mixing Valve is suitable for accurate water temperature control in single open outlet or “dead leg” multiple-point-of-use industrial process applications. Rada 50 is also applicable for institutional group fixture or zoned temperature control when ASSE 1016 certified individual fixture controls are installed at each point of use. Capable of close outlet water temperature control at flow rates between 2 and 98 gpm (7.5 and 371 lpm).

Rada 50 may be installed in parallel to increase outlet flow rates. Refer to Rada Brochure ALW-200-B.

### Rada 50 Offers:

**Safety.** Dual thermostats provide redundancy in case of individual thermostat failure. Integral check valves prevent cross connection. Has a maximum temperature locking feature with key and shutdown mode feature in the event of a cold water supply failure.\*

**Economy.** Design and functional simplicity along with easy-access internal components reduce maintenance time. PTFE coated internal parts resist mineral deposition for prolonged service life.

**Comfort.** Fast acting thermostat maintains a constant outlet water temperature by adjusting the inlet supply proportions to compensate for water temperature changes and system pressure fluctuations.

\* Shutdown mode is defined as a thermally driven bias toward the hot seat within the valve. This action may or may not reduce the outlet flow rate relative to inlet supply and outlet set point temperatures. Large capacity Thermostatic Mixing Valves (1-1/2" and 2"/40 and 50 mm) cannot be guaranteed to fully shut off in the event of a cold water supply failure.

**IMPORTANT NOTE:** If Rada 50 is to be used for group fixture or zoned temperature control in institutional showering, bathing or handwashing, then ASSE 1016 certified individual fixture controls must be installed at each point of use.

If the design/specification does not call for ASSE 1016 certified individual fixture fittings, then the largest group or zoned mixer suggested is Rada 425. If higher flows are required, create more groups/zones.

### Technical Specifications

- 2" NPT (50 mm) inlets and 2" (50 mm) NPT outlet
- DZR brass/stainless steel construction
- Operating pressures
  - Maximum: 150 psi (10 bar)
  - Minimum: 10 psi (.7 bar)
- Maximum pressure drop 20 psi (1.3 bar)
- Maximum flow rate at 9 ft/sec (2.7 m/sec):
  - 98 gpm (371 lpm)
- Minimum flow rate 2 gpm (7.5 lpm)
- ASSE 1017 and CSA B125 certified
- Flow coefficient (Cv) 22
- Integral inlet check valves
- Integral thermometer
- Dual thermostatic elements
- Shipping weight 34 lbs (15.4 kg)

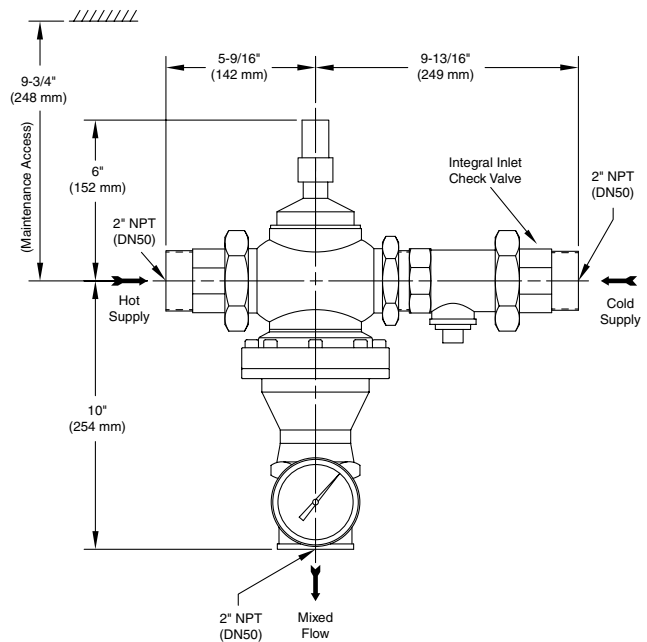

For fully detailed certified drawing, refer to CDLW #1042.

Rada Thermostatic Mixing Valves (gpm)												
Model	Pressure Drop (psi)										Min. Flow	CV
	5	10	15	20	25	30	35	40	45	50		
110	—	.75	—	1.25	—	.75	—	2.25	—	2.5	.5	.25
215	4	5	7	8	9	9	10	11	11	12	.5	1.7
320	8	11	13	15	17	19	20	22	23	24	1	3.4
425	15	22	27	31	35	38	41	44	46	49	2	6.9
40	36	51	62	72	—	—	—	—	—	—	2	16.0
50	49	70	85	98	—	—	—	—	—	—	2	22.0

## Rada 50 Components

Rada 50 is supplied with the following components:

Description	Part No.	✓
1 each Rada 50 Thermostatic Mixing Valve with integral inlet check valves and thermometer.	036-500-015	
	036-500-016	
	036-500-017	

The Rada 50 supplied with this I&M includes the following (checked) Thermostatic Element.

Part No.	Temperature Range	Stamp Code	✓
036-500-266	Low 90 - 115°F (32 - 46°C)	2195	
036-500-267	Standard 115 - 135°F (46 - 57°C)	8883	
036-500-268	High Above 135°F (57°C)	8887	

## Safety Warnings

The function of a Thermostatic Mixing Valve is to deliver water consistently at a pre-designated temperature.

Rada Thermostatic Mixing Valves are precision engineered to give continued superior and safe performance provided:

1. They are installed, commissioned, operated and maintained in accordance with the recommendations provided and accepted plumbing practices.
2. Periodic attention is given, as necessary, to maintain the product, the accessory fittings and the plumbing system in good functional order.

In keeping with every other mechanical product, Rada Mixing Valves should not be considered as functionally infallible and, as such, will never totally replace the vigilance and attention of facility nursing/bathing or other institutional supervisory or industrial safety staff.

Provided that they are installed, commissioned, operated and maintained, the risk of product failure and its associated consequences, if not eliminated, are reduced to the minimum achievable.

## Rada 50 Operating Specifications

Maximum Hot Water Supply Temperature	185°F (85°C)*
Minimum Cold Water Supply Temperature	33°F (1°C)
Optimum Minimum Inlet to Outlet Temperature Differential	18°F (10°C)
Optimum Thermostatic Control Range	86 - 122°F (30 - 50°C)**
Maximum Flow Rate	98 gpm (370 lpm)***
Minimum Flow Rate	2 gpm (7.5 lpm)
Maximum Inlet Supply Pressure	150 psi (10 bar)
Minimum Inlet Supply Pressure	10 psi (0.7 bar)
Maximum Inlet to Outlet Pressure Differential (pressure drop)	20 psi (1.4 bar)

**Inlet supply pressure must be nominally equal.**

\*Rada 50 can accept temporary excursions above 185°F (85°C) and maintain control without sustaining internal damage. (ASSE 1017 certification requires exposure to 200°F (93°C) for a period of 30 minutes). Prolonged operation of the mixing valve at such elevated temperatures is not recommended.

\*\*Rada 50 can be supplied with a high temperature thermostat for applications where the outlet temperature required is greater than 130°F (54°C).

\*\*\* Maximum flow rate determined at 9 ft/sec pipeline velocity.

## Rada 50 Installation

---

The Rada 50 Thermostatic Mixing Valve must be installed as per the piping schematic provided below. Failure to follow this directive will compromise valve/system performance, void all warranties and may create a user comfort issue and safety concern.

Armstrong has Rada technical support personnel available from 8:00 a.m. to 5:00 p.m. EST. Call Toll Free 1-888-HOT HOSE.

### Notes:

1. Rada 50 may be installed in a vertical or horizontal position.
2. Rada 50 must be installed in a standard **HOT-LEFT/COLD-RIGHT** inlet supply configuration. There are red (hot) and blue (cold) markings on each valve. The inlet supplies must always match the corresponding inlet ports on the valve.
3. Be sure to thoroughly flush the pipework before fitting the Rada 50. A good quality "Y" type strainer (40 mesh minimum) should be installed on hot and cold water inlets to mixing valve.
4. Be sure to "make up" all "sweat" or "soldered" fittings ahead of time. Do not expose Rada 50 or any of its fittings to extreme temperatures (such as an acetylene or propane torch).
5. Rada 50 is pre-set at the factory to a fixed outlet temperature. It is highly unlikely that the installation site conditions will match the test conditions. As such:

### **RADA 50 MUST BE PRE-SET ON SITE BY QUALIFIED PERSONNEL.**

Rada 50 set up (commissioning) protocol is included on page 5.

6. Rada 50 requires service access beneath the bonnet assembly. A minimum access clearance of 18" is suggested.

## Rada 50 Piping Schematic

---

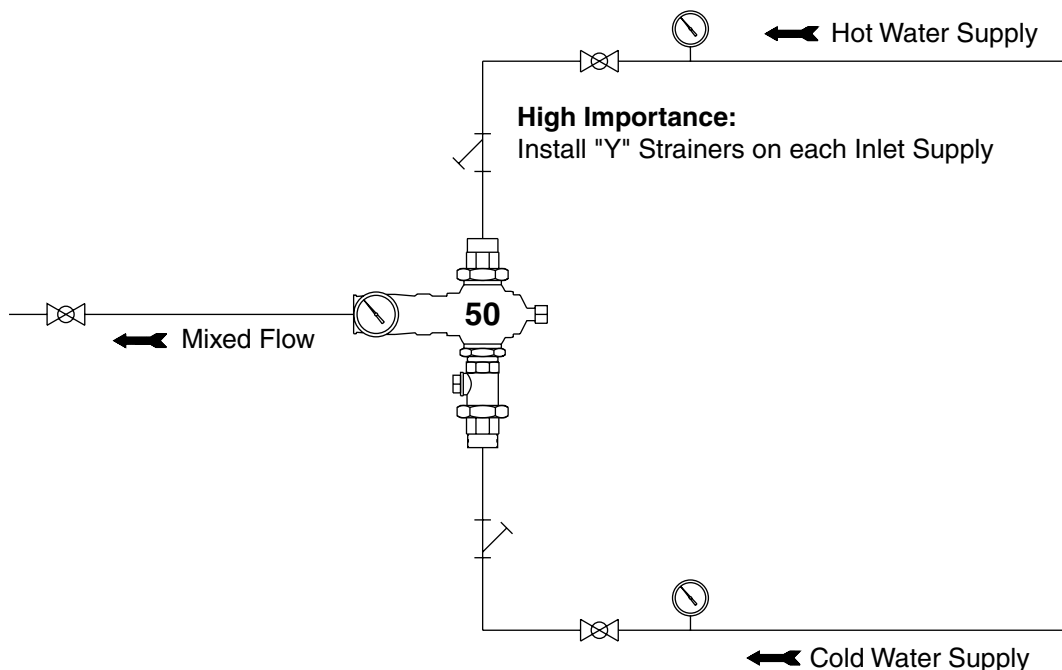

## Commissioning the Rada 50

---

**Commissioning must be carried out in accordance with these instructions, and must be conducted by designated, qualified and competent personnel.**

Ensure that the hot and cold supplies are at their designated pressures and temperatures. Open mixed water outlet and wait until the hot and cold inlet temperatures are stable. Note the mixed water temperature.

If the mixed water temperature requires adjustment, turn the adjusting key clockwise (Photo 5-1) to reduce the temperature or counterclockwise to increase the temperature. Turn the key only 1/2 turn at a time and allow a few seconds for the temperature to stabilize.

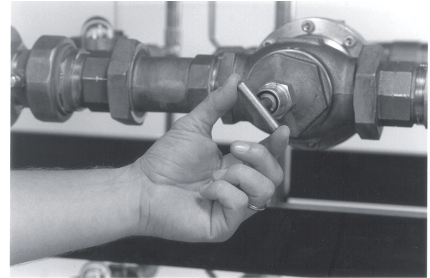

**Photo 5-1**

## Fixed Temperature Setting

---

### **Remove and store the key.**

Rada 50 is supplied with a removable temperature adjustment key. The temperature adjustment spindle is protected by a lock shield mechanism to discourage unauthorized adjustment.

## Rada 50 Servicing and Maintenance

---

Rada 50 Thermostatic Mixing Valves should be inspected annually, or more frequently where acknowledged site conditions such as high mineral content water dictate.

To service the Rada 50 proceed as follows:

**Isolate/by-pass the valve by turning off each inlet supply.  
Isolate the outlet.**

### **Step 1.**

Turn the adjustment screw, using the Temperature Adjustment key (Part No. 036-500-040) provided, counter clockwise until it comes to a stop. To make resetting easier after service, count the number of turns to full stop and note them in the box provided. Refer to Photo 5-2.

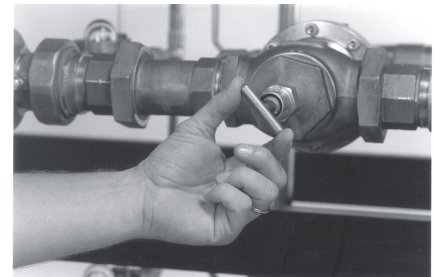

Adjustment screw turns

**Photo 5-2**

### **Step 2.**

Remove the Bonnet Assembly (Part No. 036-500-123) with a large wrench by turning counterclockwise. Refer to Photo 5-3.

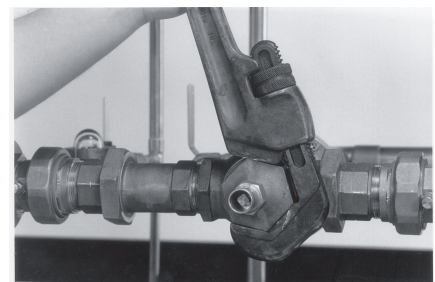

**Photo 5-3**

## Rada 50 Servicing and Maintenance

- A. Turn the Adjustment Screw fully clockwise and remove it from the Bonnet Assembly. Refer to Photo 6-1.
- B. Remove the Adjustment O-Seals (3) and Cover O-Seal (Service/O-Seal Kit Part No. 036-500-125).
- C. Clean and inspect the Cold Valve Face along with all the other machined surfaces using a scouring cloth or a domestic pot cleaner.
- D. Reinstall O-Seals into Bonnet Assembly after first applying a silicone-based lubricant such as Dow 111 and re-install adjustment screw.

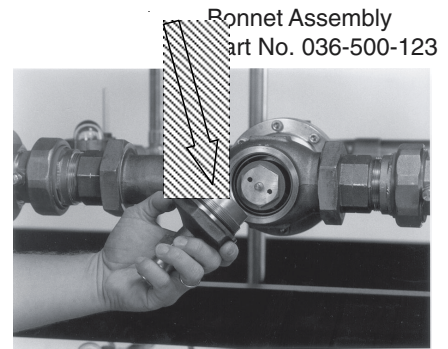

**Bonnet Assembly Servicing:**  
Refer to Drawing 1 Page 11  
**Photo 6-1**

### Step 3.

Fit the Cartridge Removal Tool (Part No. 036-500-041) into the two tappings on the face of the Cartridge Assembly (Part No. 036-500-08X). Refer to Photo 6-2.

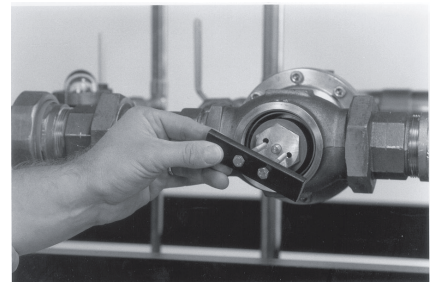

**Photo 6-2**

### Step 4.

Gently withdraw the Cartridge Assembly, the Return Spring and Spring Support Washer. Refer to Photo 6-3.

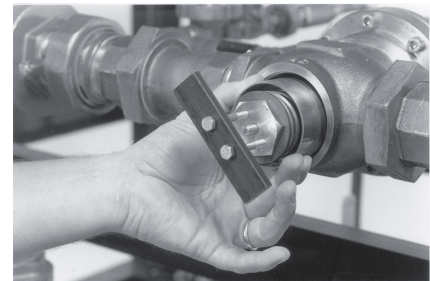

**Photo 6-3**

### Step 5.

Remove Slide Valve Seal (the slide valve seal consists of a white teflon® and black EPDM seal) from the Valve Body; clean seal groove, replace Slide Valve Seal after first applying a silicone based lubricant such as Dow 111. Refer to Drawing 1 Page 8.

### Step 6.

Using two wrenches, grip the hex at each end of the Cartridge Assembly and carefully unscrew and remove whichever end piece comes loose first. Refer to Drawing 2 Page 8.

### Step 7.

Remove the Thermostatic Element (Part No. 036-500-26X). Refer to Photo 6-4.

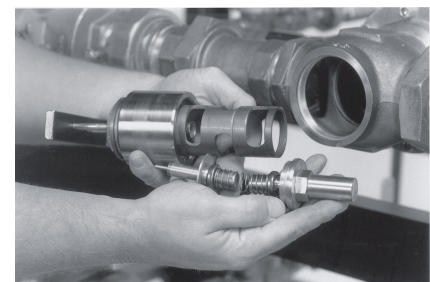

**Photo 6-4**

## Rada 50 Servicing and Maintenance

---

### Step 8.

Using a screwdriver placed through the cartridge body to “hold back” carefully unscrew the remaining end cap on the Cartridge Assembly. Refer to Photo 7-1.



Photo 7-1

### Step 9.

Clean the Slide Valve using a scouring cloth or a domestic pot cleaner but do not attempt to remove the slide valve from the spool. Refer to Drawing 2 Page 8.

**Do not use the scouring cloth on the spool, you will scratch the specially coated surface. Use a soft cloth and water.**

### Step 10.

Ensure that the inner surfaces of the Element Guide, Spool and Spool End cap are clean.

### Step 11.

Replace Push Rod Seal (Service/O-Seal Kit Part No. 036-500-125) on Push Rod within Element Guide and reassemble. Refer to Drawing 2 Page 8.

### Step 12.

Reinstall Element Guide into Cartridge Body being careful to locate the Element Guide at the end of the cartridge, which houses the slide valve. Do not over torque. Refer to Drawing 2 Page 8.

### Step 13.

Replace Thermostatic Element after first applying a silicone-based lubricant such as Dow 111 to the pistons at either end. The Thermostatic Element comprises two thermostats joined by a spring. Insert the complete assembly so that the thermostat with the flange (baffle plate) locates first. Refer to Photo 7-2.

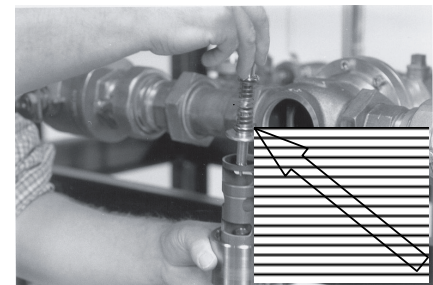

flange (baffle plate)

Photo 7-2

### Step 14.

Replace the Spool Endcap using care not to over torque. Refer to Drawing 2 Page 8.

### Step 15.

Replace slide valve seal (slide valve consists of a white Teflon<sup>®</sup> and black EPDM seal).

**Note:** Always use new seals (Service/O-Seal Kit Part No. 036-500-125).

### Step 16.

Reinstall the Spring Support Washer and Return Spring. Refer to Drawing 1 Page 8.

### Step 17.

Reinstall the Cartridge Assembly into the Valve Body.

### Step 18.

Replace Bonnet Assembly with the adjustment screw turned fully counter-clockwise.

### Step 19.

Refer to your reminder on Page 5, Step 1, and return adjustment screw to its original set point. Pressure test and re-commission the Valve following the directions on Page 5.

**Drawing 1**

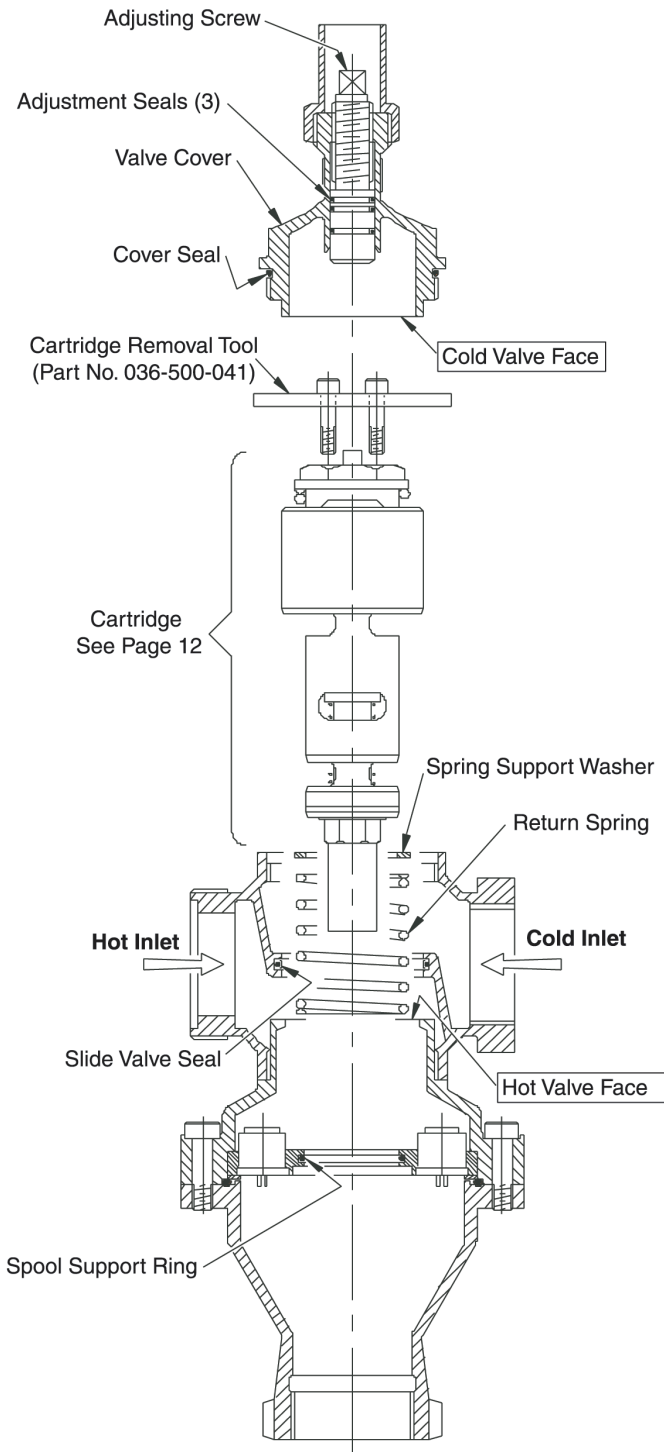

**Drawing 2**

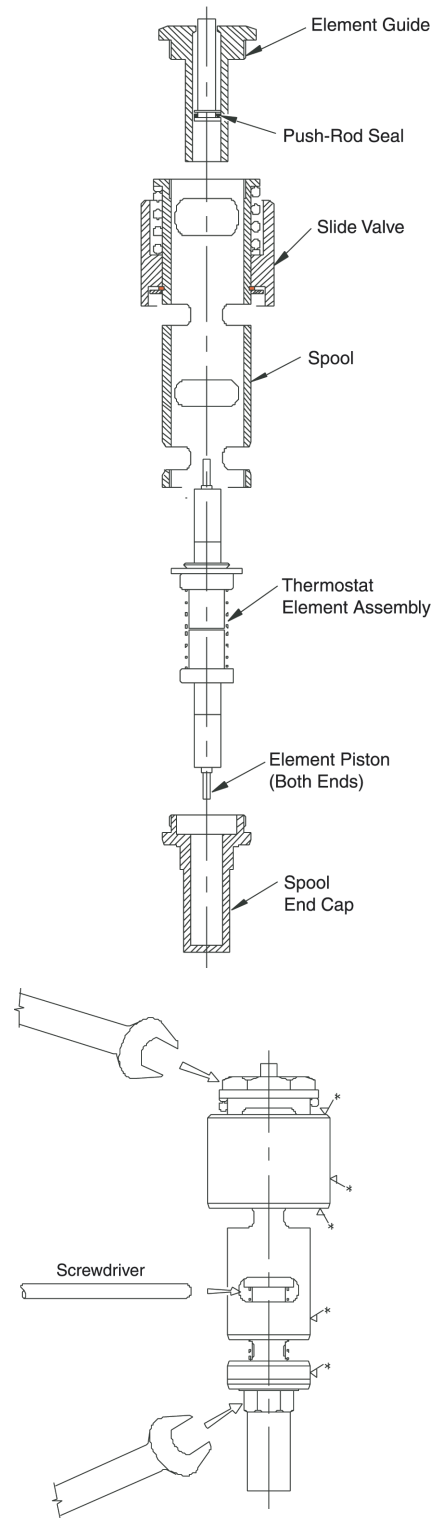

\* Indicates sealing surfaces which must be clean, smooth and undamaged.

# Rada 50 Parts List

**Bonnet Assembly**  
Part No. 036-500-123

**Cartridge Assembly**  
Part No. 036-500-085  
086  
087

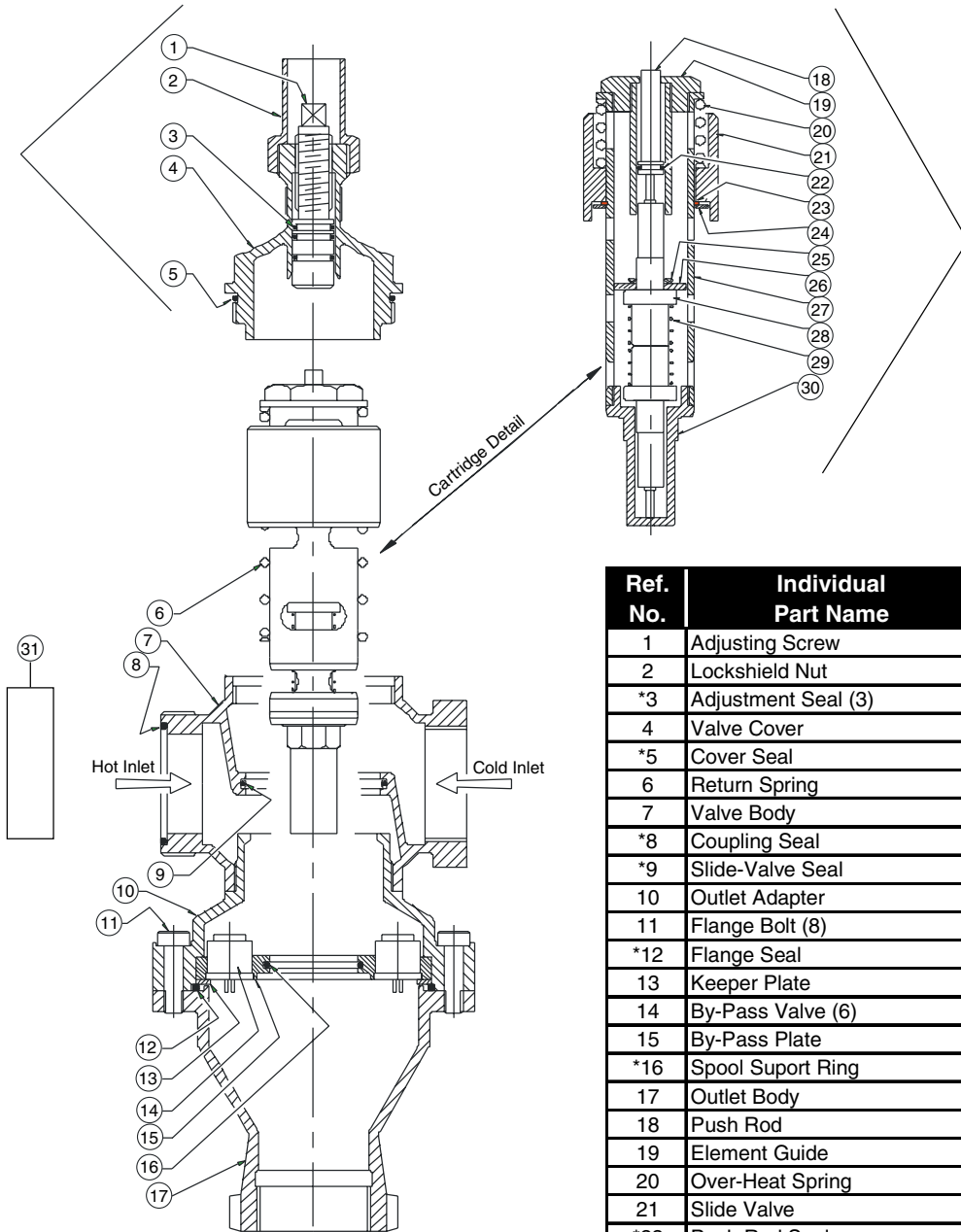

Ref. No.	Individual Part Name	Spare Part Assembly Name
1	Adjusting Screw	
2	Lockshield Nut	
*3	Adjustment Seal (3)	Bonnet Assembly
4	Valve Cover	
*5	Cover Seal	
6	Return Spring	Consult Factory
7	Valve Body	
*8	Coupling Seal	
*9	Slide-Valve Seal	
10	Outlet Adapter	Consult Factory
11	Flange Bolt (8)	Screw Pack
*12	Flange Seal	
13	Keeper Plate	
14	By-Pass Valve (6)	Consult Factory
15	By-Pass Plate	
*16	Spool Support Ring	
17	Outlet Body	Consult Factory
18	Push Rod	
19	Element Guide	
20	Over-Heat Spring	
21	Slide Valve	
*22	Push Rod Seal	Cartridge Assembly
23	Slide Valve Retainer	
*24	Spring Support Washer	
†25	Baffle Plate Retainer	
†26	Baffle Plate	
27	Spool	
†28	Thermostatic Element (2)	
†29	Element Support Spring	
30	Spool End-Cap	
31	Inlet Check Valve	Inlet Check Valve Kit (2)

\* Available in Service/O-Seal Pack Part No. 036-500-125

† Also included with Thermostat Assembly Part No. 036-500-266

267

268

## Rada 50 Part Numbers

Part No.	Description	System Temp. Range
036-500-040	Temperature Adjustment Key	—
036-500-041	Cartridge Removal Tool	—
036-500-125	Service/O-Seal Pack	—
036-500-266	Thermostatic Element Low Temperature	90 - 115°F (32 - 46°C)
036-500-267	Thermostatic Element Standard	115 - 135°F (46 - 57°C)
036-500-268	Thermostatic Element High Temperature	Above 135°F (57°C)
036-500-085	Cartridge Assembly Low Temperature	90 - 115°F (32 - 46°C)
036-500-086	Cartridge Assembly Standard	115 - 135°F (46 - 57°C)
036-500-087	Cartridge Assembly High Temperature	Above 135°F (57°C)
036-500-123	Rada 50 Bonnet Assembly	—
036-500-142	Screw Pack Rada 40 and 50 (6) Item 11	—
036-500-278	Inlet Check Valve Kit (2 each)	—

## Fault Diagnosis

Symptom	Cause/Action
1. <b>Mixed Water Temperature too high when mixed water is being used.</b>	a. Temperature setting too high. Temperature has been set when hot supply temperature is too low. Re-adjust temperature setting. See Servicing and Maintenance beginning on Page 5.
	b. Hot water has migrated into cold water supply. Close all mixed water outlets and check that cold supply pipe work remains cold.
	c. Thermostat element has failed. Replace the thermostat element. See Servicing and Maintenance beginning on Page 5.
2. <b>Only hot or cold water from outlet.</b>	a. Inlet supplies reversed (i.e. hot supply to cold inlet). Check - Rectify.
	b. No hot water reaching mixing valve. Check.
	c. Check strainers and inlet fittings for blockage.
	d. Refer to <b>symptom 6 below</b> .
	e. Installation conditions continuously outside operating parameters.
3. <b>Fluctuating or reduced flow rate.</b>	Normal function of mixing valve when operating conditions are unsatisfactory.
	a. Check strainers and inlet/outlet fittings for flow restriction.
	b. Ensure that minimum flow rate is sufficient for supply conditions.
	c. Ensure that dynamic inlet pressures are nominally balanced.
	d. Ensure that inlet temperature differentials are sufficient.
	e. (Subject to rectification of supply conditions). Check thermostatic performance; renew cartridge assembly if necessary.
4. <b>No flow from mixing valve outlet.</b>	Check inlet isolators are fully open.
	a. Check strainers and inlet/outlet fittings for blockage.
	b. Hot or cold supply failure; thermostat holding correct shutdown function. Rectify.
5. <b>Blend temperature drift.</b>	Indicates operating conditions changed.
	a. Refer to <b>symptom 3 above</b> .
	b. Hot supply temperature fluctuation (rectify and refer to <b>Commissioning</b> Page 5).
	c. Supply pressure fluctuation. Check - Rectify.
6. <b>Hot water in cold supply or vice versa</b>	Indicates check valves require maintenance.
7. <b>Water leaking from valve body.</b>	Seal(s) worn or damaged.
	a. Obtain Seal Pack, and renew all seals.
8. <b>Mixed water temperature varies, and does not respond to adjustment.</b>	a. The "Cartridge" has seized in the Thermostatic Mixing Valve. Carry out a full service. See Servicing and Maintenance beginning on Page 5.
	b. The "Thermostat Element" has failed. Replace Thermostat Element. See Servicing and Maintenance beginning on Page 5.
9. <b>Mixed water flow rate is reduced.</b>	a. Partly blocked strainers. Check - Clean/Replace.
	b. Supply pressure has fallen. Check system at incoming main and other accessible points downstream.
	c. Extra demand has been added to the system. Check maximum flow-rate for the "Mixing Valve" against maximum expected flow-rate. See Page 3.
10. <b>Mixed water temperature suddenly runs cold.</b>	a. Maximum allowable flow-rate has been exceeded. See Page 3. Fit auxiliary mixing valve in parallel or reduce the outlet demand.

## Limited Warranty and Remedy

Armstrong-Lynnwood, Inc. ("Armstrong") warrants to the original user of those products supplied by it and used in the service and in the manner for which they are intended, that such products shall be free from defects in material and workmanship for a period of one (1) year from the date of installation, but not longer than 15 months from the date of shipment from the factory. This warranty does not extend to any product that has been subject to misuse, neglect or alteration after shipment from the Armstrong factory. Except as may be expressly provided in a written agreement between Armstrong and the user, which is signed by both parties, Armstrong **DOES NOT MAKE ANY OTHER REPRESENTATIONS OR WARRANTIES, EXPRESS OR IMPLIED, INCLUDING, BUT NOT LIMITED TO, ANY IMPLIED WARRANTY OF MERCHANTABILITY OR ANY IMPLIED WARRANTY OF FITNESS FOR A PARTICULAR PURPOSE.**

The sole and exclusive remedy with respect to the above limited warranty or with respect to any other claim relating to the products or to defects or any condition or use of the products supplied by Armstrong, however caused, and whether such claim is based upon warranty, contract, negligence, strict liability, or any other basis or theory, is limited to Armstrong's repair or replacement of the part or product, excluding any labor or any other cost to remove or install said part or product, or at Armstrong's option, to repayment of the purchase price. As a condition of enforcing any rights or remedies relating to Armstrong products, notice of any warranty or other claim relating to the products must be given in writing to Armstrong: (i) within 30 days of last day of the applicable warranty period, or (ii) within 30 days of the date of the manifestation of the condition or occurrence giving rise to the claim, whichever is earlier. **IN NO EVENT SHALL ARMSTRONG BE LIABLE FOR SPECIAL, DIRECT, INDIRECT, INCIDENTAL OR CONSEQUENTIAL DAMAGES, INCLUDING, BUT NOT LIMITED TO, LOSS OF USE OR PROFITS OR INTERRUPTION OF BUSINESS.** The Limited Warranty and Remedy terms herein apply notwithstanding any contrary terms in any purchase order or form submitted or issued by any user, purchaser, or third party and all such contrary terms shall be deemed rejected by Armstrong.



Armstrong Hot Water Group

221 Armstrong Blvd., P.O. Box 408, Three Rivers, Michigan 49093 - USA Ph: (269) 279-3602 Fax: (269) 279-3130

**Steam Traps \ Humidifiers \ Steam Coils \ Valves \ Pumping Traps \ Water Heaters \ Hose Stations / Mixing Valves**