



# Rada 320R

## Installation and Maintenance

---

### Rada Solutions for Central Recirculation System Control

This Rada 320R Valve has been supplied for this application based upon information provided to Armstrong at the time the order was placed.

This Rada 320R Valve is configured for use in a central pumped recirculation system and should be installed as per the drawing on page 5.

This Rada 320R Valve is **not** designed to deliver tepid water to emergency fixtures.

For further information, please call our technical department Toll Free at 1-888-HOT-HOSE.

Model No.   Rada 320R  

Serial No. \_\_\_\_\_

Ship Date \_\_\_\_\_



# Rada Solutions for Central Recirculation System Control

## Rada 320R

Rada Thermostatic Mixing Valve is designed specifically to be installed as the primary control valve within a pumped recirculation system. Capable of maintaining safe, accurate water temperatures during both peak and zero-demand “idling” periods. With a Rada 320R installed as the primary temperature controller within a pumped recirculation system, there will be a zero minimum blended water flow rate/draw-off requirement. The Rada 320R features a unique integral thermostatic return limiter that maintains recirculating water temperatures within the circuit. Thermostatic return limiters eliminate the requirement for a fitted aquastat and reduce cycling wear and tear on the circulating pump.

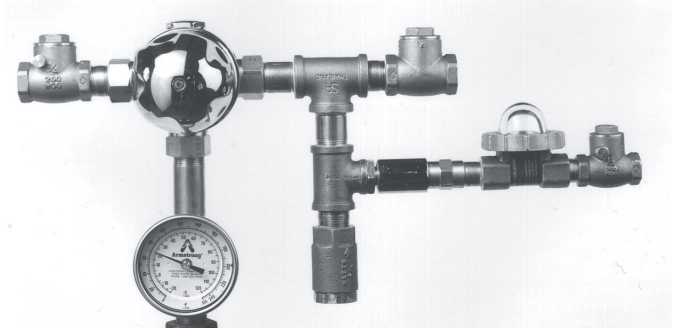

### Rada 320R Offers:

**Safety.** Dual thermostats provide redundancy in case of individual thermostat failure. Integral check valves prevent cross connection. Maximum temperature limiting and single temperature locking feature. Instant automatic shutdown prior to a 5°F (2°C) temperature rise/fall in the event of an inlet supply failure and an integral thermostatic return limiter to prevent “temperature creep” during zero-demand periods.

**Economy.** New technology and state-of-the-art materials reduce cost. Single “no spare parts” replaceable cartridge design reduces field maintenance and parts stocking requirements.

**Comfort.** Maintains a steady outlet temperature by constant internal monitoring and adjustment of recirculating hot water temperature.

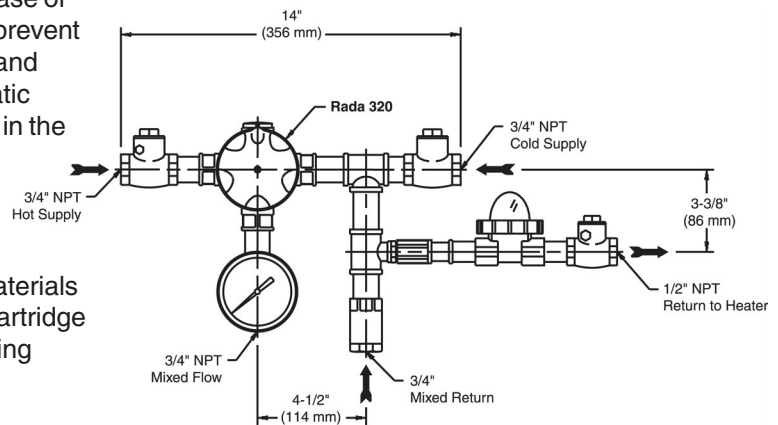

### Technical Specifications

- 3/4" (20 mm) NPT inlets and 3/4" (20 mm) NPT outlets
- Chrome-plated DZR brass/polymer construction
- Operating pressures
  - Maximum: 150 psi (10 bar)
  - Minimum: 10 psi (.7 bar)
- ASSE 1017 and CSA B125 certified
- Flow coefficient (Cv) 3.4
- Integral thermometer
- Integral check valves and strainers
- Integral sight flow indicator
- Maximum flow rate at 9 ft/sec (2.7 m/sec): 16 gpm (61 lpm)
- Integral thermostatic return limiter
- Dual thermostatic elements
- Shipping weight 25 lbs (11 kg)

### Thermostatic Mixing Valves (gpm)

Model	Pressure drop (psi)				Min. System Draw-off	Max. Flow	C <sub>v</sub>
	5	10	15	20			
320R	8	11	13	15	0	16	3.4
25R	15	22	27	31	0	26	6.9
40R	36	51	62	72	0	58	16.0
50R	49	70	85	98	0	98	22.0

**Note:** Maximum flow rates determined at 9 ft/sec pipeline velocity.

For a fully detailed certified drawing, refer to CDLW #1050.

## Rada 320R Components

Rada 320R is supplied with the following components:

Description	Part No.	✓
1 each Rada 320 Thermostatic Mixing Valve	036-320-105	✓
2 each 3/4" Inlet Swing Check Valves	039H	✓
3/4" Mixed Return Check Valve	039V	✓
1/2" Ball Flow Indicator	FIB-003-02-STD	✓
1/2" Heater Return Check Valve	039H-1/2	✓

The Rada 320R supplied with this I&M includes the following (checked) 1/2" Thermostatic Return Limiter.

Part No.	System Temperature Range	Description	✓
036-500-034	Below 130°F (54°C)	Low/Standard	
036-500-035	Above 130°F (54°C)	High	

## Safety Warnings

The function of a Thermostatic Mixing Valve is to deliver water consistently at a pre-designated temperature.

Rada Thermostatic Mixing Valves are precision engineered to give continued superior and safe performance provided:

1. They are installed, commissioned, operated and maintained in accordance with the recommendations provided and accepted plumbing practices.
2. Periodic attention is given, as necessary, to maintain the product, the accessory fittings and the plumbing system in good functional order.

In keeping with every other mechanical product, Rada Mixing Valves should not be considered as functionally infallible and, as such will never totally replace the vigilance and attention of facility nursing/bathing or other institutional supervisory or industrial safety staff.

Provided that they are installed, commissioned, operated and maintained, the risk of product failure and its associated consequences, if not eliminated, are reduced to the minimum achievable.

## Rada 320R Operating Specifications

Maximum Hot Water Supply Temperature	185°F (85°C) *
Minimum Cold Water Supply Temperature	33°F (1°C)
Optimum Inlet to Outlet Temperature Differential	21°F (12°C) **
Optimum Thermostatic Control Range	86°F (30°C) - 122°F (50°C)
Optimum Recirculation Loop Temperature Loss	15°F (8°C)
Maximum Flow Rate at 9' per second	16 gpm (61 lpm)
Minimum System Draw-off	0 gpm (0 lpm)
Maximum Inlet Supply Pressure	150 psi (10 bar)
Minimum Inlet Supply Pressure	10 psi (0.7 bar)

**Inlet supply pressure must be nominally equal**

\*Rada 320R can accept temporary excursions above 185°F (85°C) and maintain control without sustaining internal damage. (ASSE 1017 certification requires exposure to 200°F (93°C) for a period of 30 minutes). Prolonged operation of the Mixing Valve at such elevated temperatures is not recommended.

\*\* Under laboratory test conditions Rada 320R has displayed a repeatable capability to blend to within 5°F (2°C) of each inlet supply temperature. 21°F (12°C) is the optimum published differential required to achieve full thermal performance.

## Rada 320R Installation

---

The Rada 320R Thermostatic Mixing Valve must be installed as per the piping schematic provided on Page 5. Failure to follow this directive will compromise valve/system performance, void all warranties and may create a user comfort issue and safety concern.

Armstrong has Rada technical support personnel available from 8:00 a.m. to 5:00 p.m. EST. Call Toll Free 1-888-HOT HOSE.

### Notes:

1. Rada 320R may be installed in a vertical or horizontal position **BUT** the check valves and flow indicator will be affected by gravity and must be oriented in a horizontal plane only.
2. Rada 320R must be installed in a standard **HOT-LEFT/COLD-RIGHT** inlet supply configuration. There are red(hot) and blue(cold) markings on each valve. Rada 320R is provided as standard with a piped top outlet and a plugged bottom outlet. This configuration can be reversed by simply switching the outlet plug and fittings. The inlet supplies must always match the corresponding inlet ports on the valve.
3. Be sure to thoroughly flush the pipework before fitting the Rada 320R. A good quality “Y” type strainer (40 mesh minimum) should be installed on hot and cold water inlets to mixing valve.
4. Be sure to “make up” all “sweat” or “soldered” fittings ahead of time. Do not expose Rada 320R or any of its fittings to extreme temperatures (such as an acetylene or propane torch).
5. A minimum 18” clearance in front of the Temperature Control Handle is suggested for internal parts access.
6. Rada 320R is pre-set at the factory to a fixed outlet temperature of 110°F (43°C). It is highly unlikely that the installation site conditions will match the test conditions. As such:

### **RADA VALVE 320R MUST BE RE-SET ONSITE BY QUALIFIED PERSONNEL.**

Rada 320R set up (**commissioning the Rada 320R and the system**) protocol is included on Page 6.

7. Rada 320R is serviced from the front of the valve as you face it. A minimum access clearance of 18” is suggested.

# Rada 320R Recirculation System Schematic

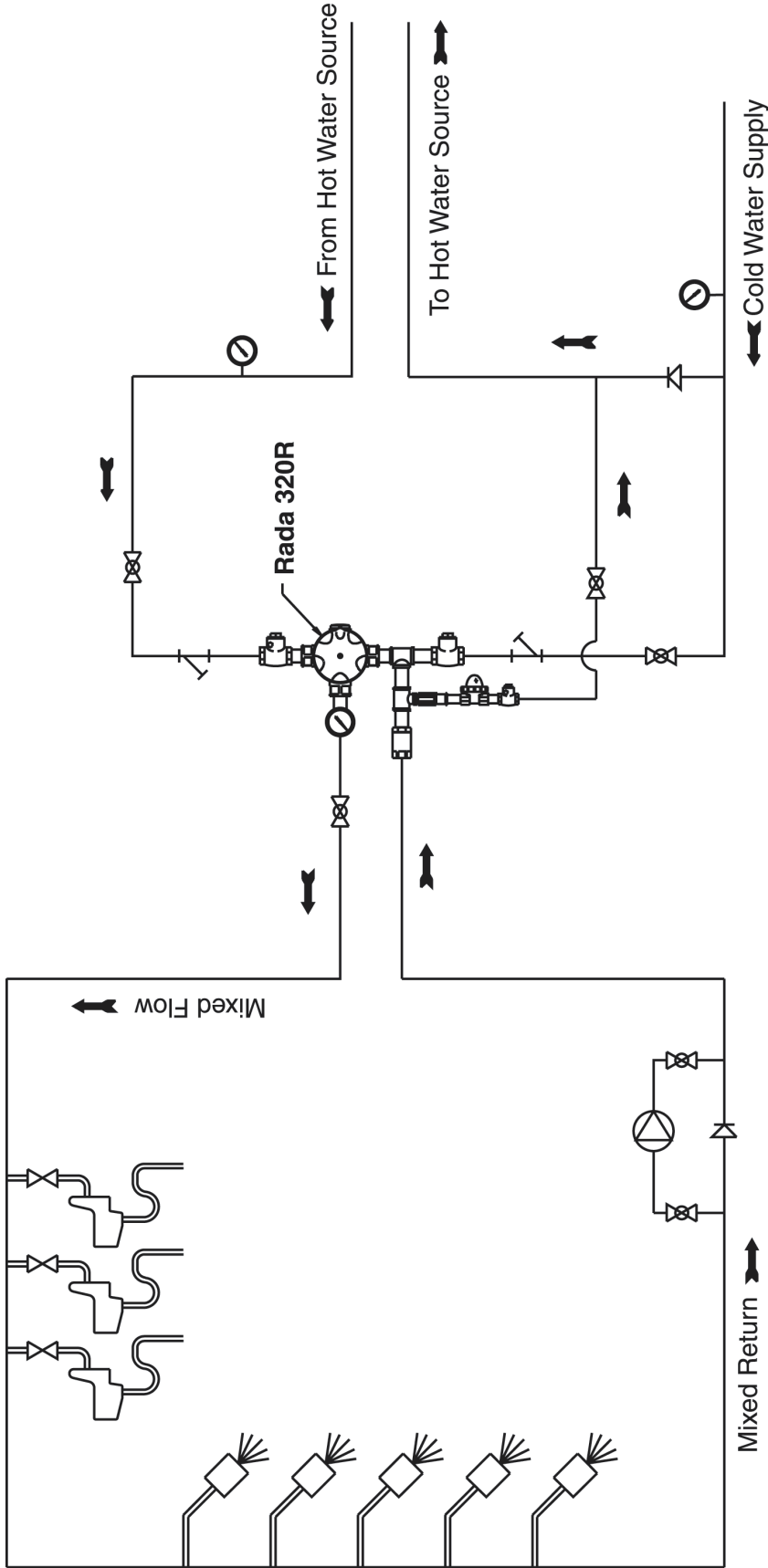

### SYSTEM LAYOUT

-LEGEND-

	Thermometer		Recirculation Pump
	Sink		Check Valve
	Shower		Isolation Valve
			Stop Valve
			Strainer

### RADA VALVE ASSEMBLY

-LEGEND-

	Thermometer		Swing Check Valve*
	Temp Limiter		Flow Indicator*
	In-Line Check Valve		

\*Oriented for piping schematic detail only. Must be installed in horizontal plane.

## Commissioning the Rada 320R and the System

---

**Commissioning must be carried out in accordance with these instructions, and must be conducted by designated, qualified and competent personnel.**

Flood the system by opening all isolation valves. Ensure that the hot and cold supplies are at their designated pressures and temperatures. Open a few mixed water outlets and wait until the hot and cold inlet temperatures are stable. Note the mixed water temperature.

If the mixed water temperature requires adjustment, turn the temperature control handle clockwise to reduce the temperature or counterclockwise to increase it. Allow a few seconds for the temperature to stabilize.

If the blend temperature required is not obtainable (not hot enough) it is likely that the mixing valve has reached the factory calibrated maximum temperature set point. To recalibrate set point see **Maximum Temperature** below.

When the mixed water temperature has been set, close the outlets which have been running and start the recirculation pump.

Observe the flow indicator while the recirculation pipework is heating up, the ball in the glass dome should be moving actively; (at this stage, the mixed water temperature may show a slight increase). When all the pipework has heated completely, the flow indicator will show a reduced flow and any temporary increase in mixed water temperature will return to normal.

**Remember:** When making temperature adjustments, two or three outlets must be running. When checking the recirculation temperature, all outlets must be closed; when outlets are running the flow indicator may show no flow, this is normal.

### **Maximum Temperature.**

After the system has been fully commissioned and monitored for performance and temperature control a second commissioning procedure is suggested. The maximum blend temperature obtainable through the mixing valve should be limited to prevent selection of a system temperature that is too hot.

Rada 320R is fully performance tested and the maximum temperature is pre-set to approximately 110°F (43°C) under ideal installation conditions at the factory.

Site conditions and design preference may dictate that the maximum temperature has to be re-set following installation.

### **Maximum Temperature Setting**

Check that an adequate supply of **hot** water is available at the hot inlet of the mixing valve.

For optimum performance the minimum temperature of the hot water must be at least 21°F (12°C) above the desired blend, however during resetting this should be close to the typical storage maximum to reduce the possibility of any blend shift due to fluctuating supply temperatures.

Temperatures should always be recorded using a thermometer with proven accuracy.

### **For Adjustable Temperature**

1. Remove the temperature knob screw using a 3 mm hexagonal wrench (supplied). Remove the temperature knob.
2. Pull off the black polymer hub assembly which may inadvertently remain attached to the inside of the temperature control handle. This is a “push fit” and can be “levered” out using a thin blade screwdriver or pliers.
3. Rotate the spindle until required maximum blend temperature is obtained at outlet point (**clockwise = decrease temperature, counterclockwise = increase temperature**). **When resistance is felt do not use force to turn any further, as this can damage the internal parts.**

## Commissioning the Rada 320R and the System

- Once the desired maximum blend temperature is achieved, re-fit the hub without disturbing the spindle: Position the hub so that the hub stop comes up against the cartridge stop (refer to Figure 6-1) preventing any further rotation in a counterclockwise direction. Check that blend temperature has not altered.
- Refit the temperature knob. Make sure that the indicator points to 9 o'clock.

**Figure 6-1**  
**Commissioning**

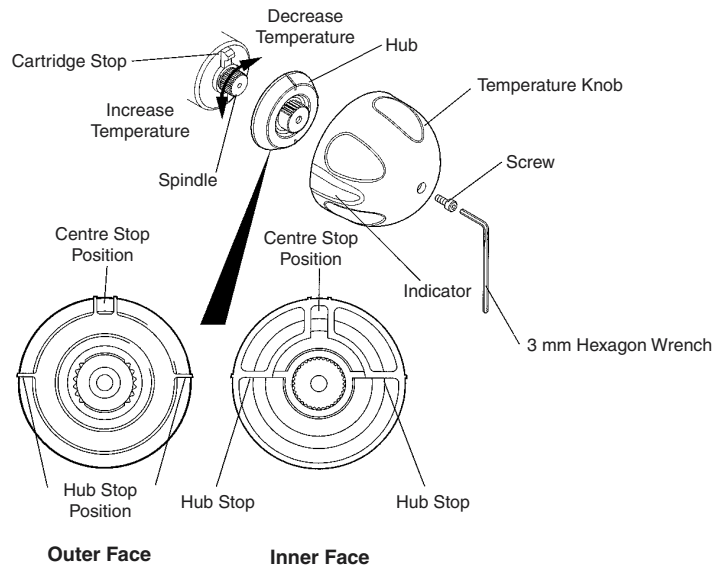

### For Locked Temperature

- Remove the temperature knob using a 3 mm hexagonal wrench (supplied).
- Pull off the black polymer hub assembly which may inadvertently remain attached to the inside of the temperature control handle. This is a "push fit" and can be "levered" out using a thin blade screwdriver or pliers.
- Rotate the spindle until required maximum blend temperature is obtained at outlet point (**clockwise = decrease temperature, counterclockwise = increase temperature**).  
**When resistance is felt do not use force to turn any further, as this can damage the internal parts.**
- Once the desired maximum blend temperature is achieved, re-fit the hub without disturbing the spindle, positioning it so that the center stop slot in the hub fits over the top of the cartridge stop (refer to Figure 6-1), preventing any further rotation in either direction. Check that the blend temperature has not altered.
- Refit the temperature knob. Make sure that the indicator points to 6 o'clock.

## Rada 320R Servicing and Maintenance

Rada 320R Thermostatic Mixing Valves should be inspected annually, or more frequently where acknowledged site conditions such as high mineral content water dictate.

It is highly recommended that as a function of the annual inspection that the two “racetrack” shaped o-seals within the valve are replaced.

Rada 320R Thermostatic Mixing Valve is of non-serviceable single “cartridge construction”. The cartridge can be removed from the valve for inspection or replacement by first removing the chromed brass temperature control handle using a 3 mm hex wrench. The black polymer hub assembly may inadvertently remain attached to the inside of the temperature control handle. This is a “push fit” and can be “levered” out using a thin blade screwdriver or pliers.

The chromed polymer temperature indicator ring, which fits beneath the temperature control handle can be “levered” off using a thin edged tool such as a razor blade knife.

**Before proceeding further be sure to isolate/by-pass the valve by turning off each inlet supply, the outlet and the return line.**

The complete cartridge assembly is accessed by first removing the 6 Phillips head-retaining screws and then smoothly drawing the cartridge out. Do not twist or apply “side load” leverage when extracting the cartridge.

When installing a new or reinstalling an existing cartridge note the raised “H” on the hot inlet of the cartridge and align to hot supply accordingly.

**Figure 8-1**

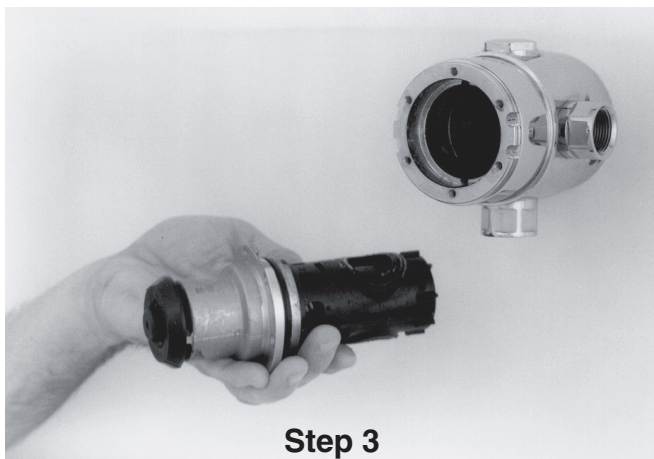
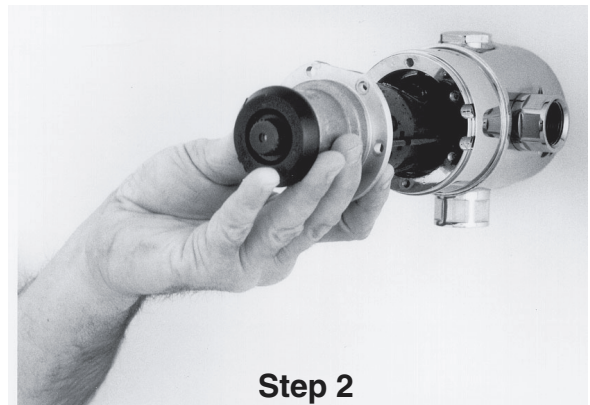
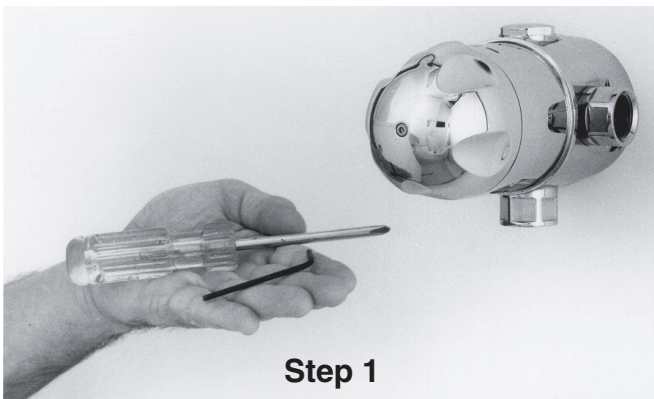

The Rada 320R Mixing Unit features a single “sealed for life” disposable internal cartridge. With an allen key (3 mm) to remove the handle retaining screw and a phillips head screwdriver to remove the 6 cartridge retaining screws, the entire mixing unit can be serviced and/or replaced in approximately 10 minutes.

## Rada 320R Spare Parts

Part No.	Description
036-414-14	Body, Rada 320 (Less Connectors)
036-414-43	Temperature Indicating Ring
036-414-51	Cartridge Assembly
036-414-80	Hub Pack
036-320-176	Inlet/Outlet Adapter, 3/4" Female
036-414-84	Seal Pack - Includes "A" Components
036-414-85	Screw Pack - Includes "B" Components
036-414-86	Backplate Kit - Includes "C" Components
036-414-92	Knob Pack
036-414-93	Blanking Cap

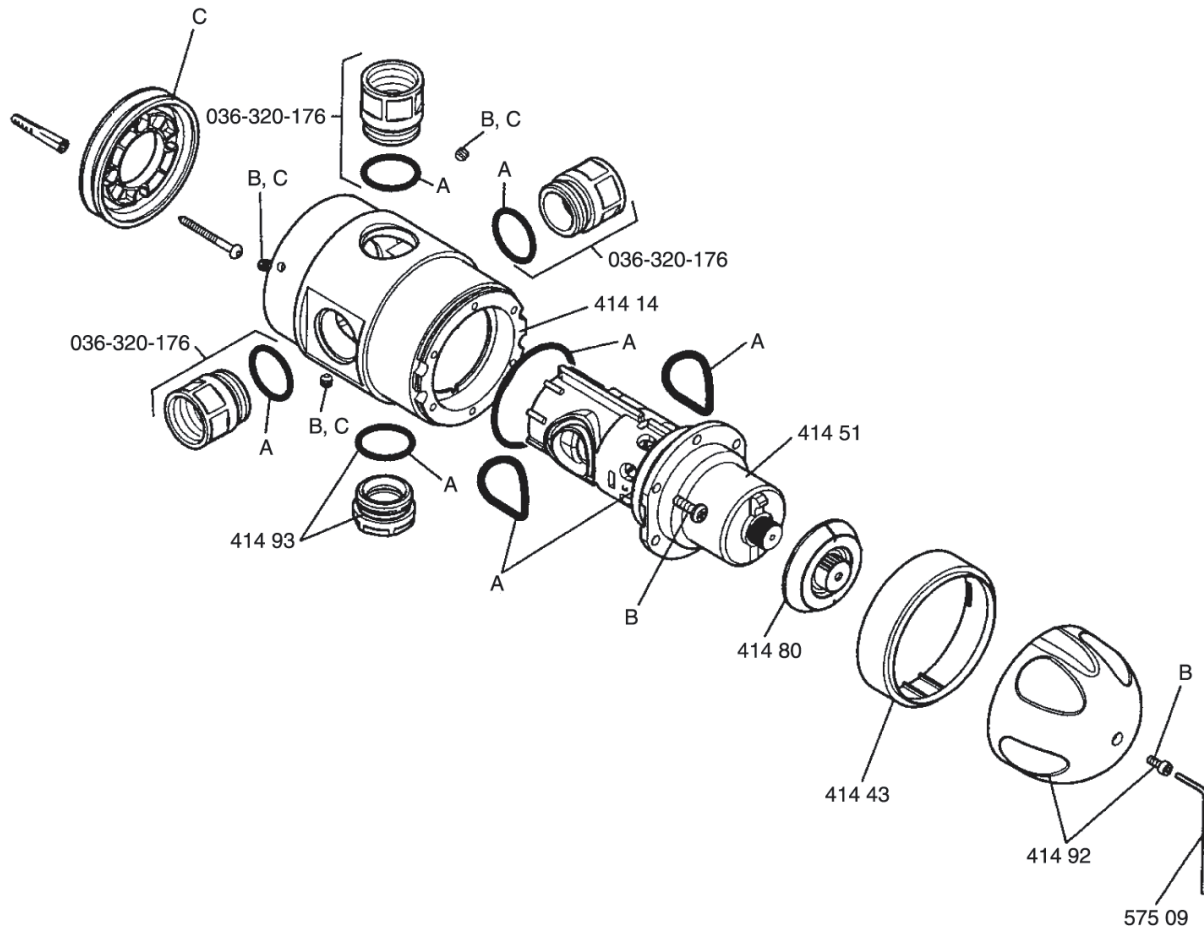

## Fitting or Replacing the Return Limiter (Part No. 036-500-034/035)

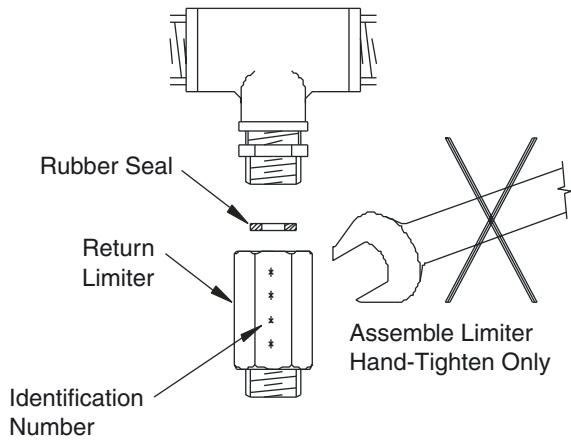

When fitting a new return limiter, make sure that its working temperature is correct for the application/system.

Tighten the limiter body in place using hand pressure only, the rubber washer will make the seal. Over-tightening with a wrench may cause damage.

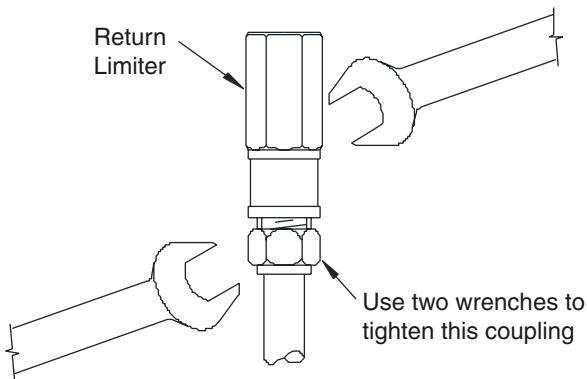

When tightening-up, or loosening-off the pipe coupling at the limiter outlet, use two wrenches so that torque is not transmitted through the limiter body.

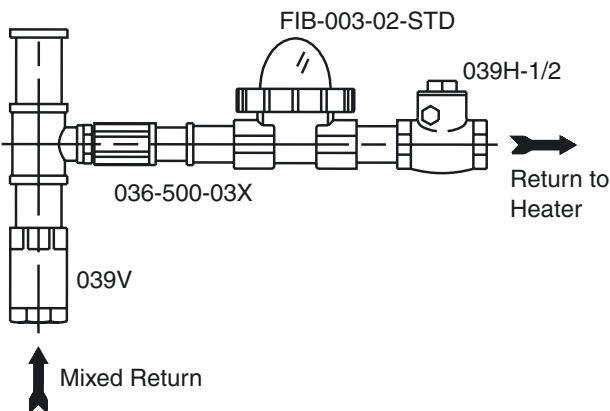

Ensure that the glass dome on the flow indicator is positioned vertically upwards. Note direction of flow.

### Rada 320R

Part No.	Description
036-500-034	1/2" Thermostatic Return Limiter Standard with Seat
036-500-035	1/2" Thermostatic Return Limiter High Temperature with Seat
FIB-003-02-STD	Ball Flow Indicator
039H-1/2	1/2" Check Valve (return line to heater)
039V	3/4" Check Valve (return line to TMV)
039H	3/4" Check Valve (TMV Inlet)

## Fault Diagnosis

Symptom	Cause	Action
1. Only hot or cold water from outlet when mixed water is being used.	a. Inlet supplies reversed (i.e.: hot to cold or vice-versa)	Check-Rectify. Note: Rada 320R is difficult to plumb with reversed lines due to the location of the integral mixed water return pipe work which must return to the cold side of the valve. If suspicion persists check rear of valve under polymer mounting plate for raised "H" (hot) on appropriate inlet. If sight evaluation is not possible consult factory Technical Support for additional diagnostic tips.
	b. No hot water available from hot water source.	Check-Rectify.
	c. Screens/filters occluded or inlet supply fittings plugged.	Check-Rectify.
	d. Refer to <b>Symptom 4 below.</b>	Refer to <b>Symptom 4 below.</b>
	e. Proportioning mechanism (shuttle) trapped against hot/cold seat.	Refer to Servicing/Maintenance on Pages 7 and 8 and Fig. 8-1. Inspect - Rectify - Replace.
2. No flow from Mixing Valve outlet.	a. Hot or Cold inlet supply failure; Thermostat holding correct shutdown function.	Check-Rectify.
	b. Screens/filters blocked or inlet supply fittings plugged.	Check-Rectify.
	c. Mixing valve has not been commissioned correctly and proportioning mechanism (shuttle) is located against cold seat preventing re-circulation flow.	Refer to Pages 6 and 7 and turn handle counterclockwise until flow commences.
3. Mixed water temperature at TMV outlet fluctuates and does not respond to adjustment.	a. Thermostat not operating correctly.	Replace cartridge 036-414-51.
	b. Mixing Valve operating below minimum required flow rate and return limiter not functioning correctly.	Check that at least 1 GPM is flowing through valve and/or return limiter is functional.
	c. Un-equal inlet supply pressures.	Check-Rectify.
	d. Inlet supply pressures fluctuating beyond valves capability to correct.	Check-Rectify.
	e. Hot water supply temperature fluctuating beyond valves capability to correct.	Check by <b>carefully</b> sensing inlet hot supply pipe work - rectify.
	f. Partially occluded screens/filters or partially blocked inlet fittings.	Check-Rectify.
4. Hot water in cold supply and vice-versa.	a. Indicates non-functioning check valve(s)	Diagnose by turning off mixed water outlet flow and pump and check to see if inlet hot pipe work becomes cold and vice-versa.
5. Mixed water temperature too high when mixed water is being used.	a. Mixing Valve has not been commissioned correctly and set too high.	Refer to Commissioning on Page 6 - Rectify.
	b. Mixing Valve has not been commissioned correctly and was set when the hot supply temperature was too low.	Refer to Commissioning on Page 6 - Rectify.
	c. Hot water is migrating into cold supply.	See Item 4 above.
	d. Thermostat not operating correctly.	Replace cartridge 036-414-51.
6. Mixed water temperature increases when no mixed water is being used (re-circulation system is under pump only demand).	a. Return limiter not operating correctly.	Replace Return Limiter Part No. 036-500-03X

## Fault Diagnosis (cont.)

Symptom	Cause	Action
7. Mixed water temperature too low when mixed water is being used.	a. Mixing Valve has not been commissioned correctly and is set too low.	Refer to Commissioning on Page 6 - Rectify.
	b. Hot water heater is not keeping up with demand.	Check-Rectify.
8. Mixed water temperature too low when no mixed water is being used (re-circulation system is under pump only demand).	a. Re-circulation has failed due to pump malfunction or system air locking.	Check-Rectify.
	b. Pump too small to adequately distribute water.	Refer to a trained and appropriate authority for system sizing assistance.
	c. See Item 7a above.	
9. Mixed water flow rate is reduced when mixed water is being used.	a. Partially occluded inlet screens/filters or partially blocked inlet fittings.	Check-Rectify.
	b. Inlet supply pressure has fallen.	Check-Rectify.
	c. Accumulated pressure losses within the system are too high.	Refer to a trained and appropriate authority for system sizing assistance.
	d. Additional demand has been placed on system.	Refer to a trained and appropriate authority for system sizing assistance.
10. Water leaking from valve body.	a. Seals worn or damaged.	Obtain Seal Pack 036-414-84.

## Limited Warranty and Remedy

Armstrong-Lynnwood, Inc. ("Armstrong") warrants to the original user of those products supplied by it and used in the service and in the manner for which they are intended, that such products shall be free from defects in material and workmanship for a period of one (1) year from the date of installation, but not longer than 15 months from the date of shipment from the factory. This warranty does not extend to any product that has been subject to misuse, neglect or alteration after shipment from the Armstrong factory. Except as may be expressly provided in a written agreement between Armstrong and the user, which is signed by both parties, Armstrong **DOES NOT MAKE ANY OTHER REPRESENTATIONS OR WARRANTIES, EXPRESS OR IMPLIED, INCLUDING, BUT NOT LIMITED TO, ANY IMPLIED WARRANTY OF MERCHANTABILITY OR ANY IMPLIED WARRANTY OF FITNESS FOR A PARTICULAR PURPOSE.**

The sole and exclusive remedy with respect to the above limited warranty or with respect to any other claim relating to the products or to defects or any condition or use of the products supplied by Armstrong, however caused, and whether such claim is based upon warranty, contract, negligence, strict liability, or any other basis or theory, is limited to Armstrong's repair or replacement of the part or product, excluding any labor or any other cost to remove or install said part or product, or at Armstrong's option, to repayment of the purchase price. As a condition of enforcing any rights or remedies relating to Armstrong products, notice of any warranty or other claim relating to the products must be given in writing to Armstrong: (i) within 30 days of last day of the applicable warranty period, or (ii) within 30 days of the date of the manifestation of the condition or occurrence giving rise to the claim, whichever is earlier. **IN NO EVENT SHALL ARMSTRONG BE LIABLE FOR SPECIAL, DIRECT, INDIRECT, INCIDENTAL OR CONSEQUENTIAL DAMAGES, INCLUDING, BUT NOT LIMITED TO, LOSS OF USE OR PROFITS OR INTERRUPTION OF BUSINESS.** The Limited Warranty and Remedy terms herein apply notwithstanding any contrary terms in any purchase order or form submitted or issued by any user, purchaser, or third party and all such contrary terms shall be deemed rejected by Armstrong.



Armstrong Hot Water Group

221 Armstrong Blvd., P.O. Box 408, Three Rivers, Michigan 49093 - USA Ph: (616) 279-3602 Fax: (616) 279-3130

www.armstrong-intl.com

Toll Free: (888) HOT-HOSE