

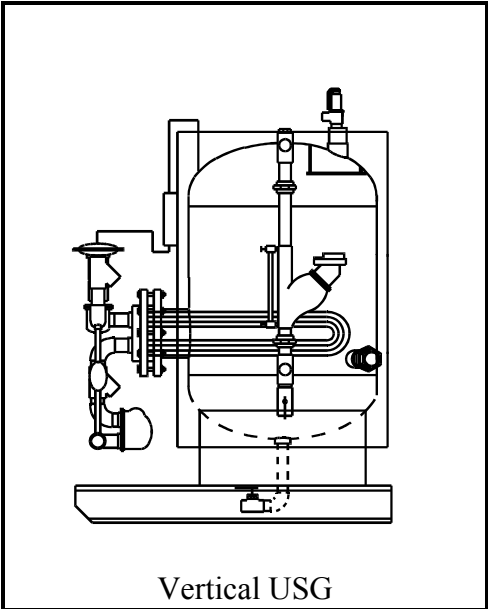

Installation, Operation and Maintenance

Unfired Steam Generators (Series RB)

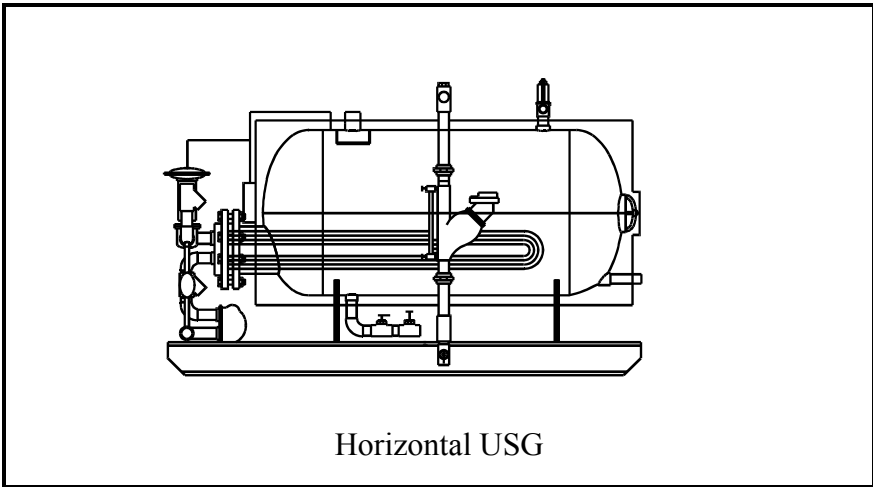

Disclaimers

This Installation, Operation, and Maintenance Manual is intended to be as complete and up to date as possible. It covers the installation, operation, and maintenance procedures for Armstrong's Unfired Steam Generators (USG Series). Armstrong reserves the right to update this manual and other product information concerning installation, operation, and / or maintenance, at any time and without obligation to notify product owners of such changes.

Armstrong is not responsible for inaccuracies in specifications, procedures, and / or the content of other product literature, supplied by the manufacturers of components used in Armstrong Unfired Steam Generators (i.e.: valves, pressure controls, gauges, etc.). Armstrong strives to use only the highest quality components in building the USG Series Unfired Steam Generators. However, Armstrong has no direct control over their manufacture, or their consistent quality.

Armstrong is not responsible for injury to personnel or product damage due to the improper installation, operation, and / or maintenance of Armstrong Unfired Steam Generators. All installation, operation, and maintenance procedures should only be performed by trained / certified personnel. All personnel performing these procedures should completely and carefully read and understand all supplied materials before attempting the procedures. All personnel should pay strict attention to all Notes, Cautions, and Warnings that appear within the procedures detailed in this manual.

Armstrong welcomes user input as to suggestions for product or manual improvement.

Table of Contents

<u>Section</u>	<u>Page</u>
General Information.....	1
Energy and Power Sources	1
Construction.....	2
Advantages and Benefits of Armstrong Unfired Steam Generators.....	4
Warranty Information	4
Contact Information	4
General Notes and Warnings	5
Notes	5
Warnings	6
Product Features and Specifications	8
Installation	9
Transporting and Unpacking the Unit	9
Examining the Unit	9
Mounting the Unit.....	9
Familiarization with the Unit and Components.....	10
Connecting the Feed Water Source and Generated Clean Steam Outlet.....	10
Connecting the Energy Source	11
Connecting the Steam Condensate Line or the Boiler Water / High Temperature Water Return Lines.....	12
Piping the Relief Valve to Vent and Drain	13
Connectin	
Electrically Activated Controls.....	13
Connecting Pneumatically Activated Controls.....	14
Connecting the Drain / Blowoff Line	14
RBCM-2002 Solid State Control Module Installation, Operation and Maintenance	15
Completing Installation.....	31
Operation	32
Startup Procedures	32
Shutdown Procedures	33
Daily Operation - Standard Unfired Steam Generator.....	34
Daily Operation - Unfired Steam Generator with Optional Equipment	36

Parts List	38
Replaceable Parts List.....	38
Suggested Spare Parts.....	38
Ordering Information.....	39
Inspection.....	40
Troubleshooting.....	41
Probable Cause and Remedy	41
Maintenance.....	44
Power Connections - Rewiring.....	44
Pneumatic (Instrument Air) Connections - Refitting.....	45
Heat Exchanger Coil and Gaskets - Inspection and Replacement.....	45
Level Controller - Inspection and Replacement	49
Inlet, Outlet, and Condensate / Water Return Line and Manual Shutoff Valves - Replacement.....	50
Pressure Gauge (Energy Source) - Replacement.....	51
Pressure Gauge (Clean Steam) - Replacement	52
Pressure Relief Valve (Tank) - Replacement	52
Solenoid Safety System - Inspection and Replacement.....	53
Strainers - Inspection and Replacement.....	54
Pressure Control Valve - Inspection and Replacement	55
Traps (Main and Auxiliary) - Replacement (Steam Systems Only).....	57
Appendix A.....	58
Appendix B.....	60

General Information

This Installation, Operation, and Maintenance Manual is designed as a procedural guide for all Armstrong Carbon (Black) or Stainless Steel Unfired Steam Generators. Covered in this manual are:

- ❖ USG Series Vertical Unfired Steam Generators; and
- ❖ USG Series Horizontal Unfired Steam Generators.

Energy and Power Sources

For Generating Steam

Armstrong Unfired Steam Generators can be configured and manufactured to use one (1) of three (3) possible energy sources for generating clean steam:

steam;
boiler water; or
high temperature water.

Note: Most Armstrong Unfired Steam Generators use steam as the energy source for generating clean steam. Therefore, procedures detailed in this manual will be geared towards the installation, operation, and maintenance of steam powered units. When procedures differ substantially for the installation, operation, and /or maintenance of units powered by either boiler water or high temperature water, notes will be included giving specific instructions for those units.

The following table lists the range of acceptable pressures at the inlet for each energy source.

Energy Source	Minimum Pressure (PSI)	Maximum Pressure (PSI)
Steam	0	150
Boiler Water	0	150
High Temperature Water	unknown	400

Note: Consult the design specifications for the unit, as well as the nameplate attached to the exterior of the tank and individual specification tags on pressure related components and controls, for design specifications and maximum pressure for the unit.

For Relays and Controls

Armstrong Unfired Steam Generators can be equipped with either electronically or pneumatically activated controls to regulate pressure and water level. The electronic controls used, depending on individual design specifications, can range in power requirements from 120 volt single phase to 480 volt three phase. Pneumatic controls, depending on individual design specifications, require instrument air in pressures ranging from 15 to 100 psi. Consult the individual design specifications for the unit and controls for the exact requirements.

Construction

All Armstrong Unfired Steam Generators are constructed from superior materials and utilize only the highest quality components. Each Unfired Steam Generator meets or exceeds all applicable American Society of Mechanical Engineers (A.S.M.E.) Code regulations.

Tanks and Linings

Depending on the unit purchased, Armstrong Unfired Steam Generators are equipped with either Carbon (Black) or Stainless Steel tanks. Each tank is designed and constructed in strict accordance with the latest A.S.M.E. Code regulations, stamped in accordance with the applicable section of the A.S.M.E. Code, and accompanied by the applicable certificates. Each tanks is manufactured using pressure vessel quality plate and welded by certified welders. All tanks are registered with the National Board of Boiler and Pressure Vessel Inspectors.

Each Armstrong Unfired Steam Generator is equipped with an A.S.M.E. approved relief valve and an external drain, providing a means to remove accumulated sediment.

Unfired Steam Generator Jackets

The jackets used for all Armstrong Unfired Steam Generators are constructed of twenty (20) gauge metal and professionally coated with a superior quality enamel paint. This procedure increases corrosion resistance and provides an attractive, easy to maintain surface.

A nameplate, mounted to the jacket, bears the model and serial numbers of the unit. ***These numbers should be included in all correspondence regarding the unit.***

Insulation

All Armstrong Unfired Steam Generators contain a two inch (2") layer of insulation between the tank and jacket. Depending on individual design specifications, the insulation consists of either fiberglass or foam.

Heat Exchanger Coils

The "U-Bend" heat exchanger coils are manufactured with steel or stainless tubesheet, with a cast iron or steel fabricated head.

Components

All other components included in Armstrong Unfired Steam Generators have been specifically selected to meet the individual design specifications of each unit. Each component is judged to be of highest quality to provide long life and superior performance.

Advantages and Benefits of Armstrong Unfired Steam Generators

- ❖ Offers years of reliable, trouble free service.
- ❖ High quality design, construction, and components.
- ❖ Built and "Packaged" to meet exact customer design specifications.
- ❖ Armstrong "Packaging" helps keep installation time to a minimum.
- ❖ Offers a wide range of configurations and capacities.
- ❖ Configured to utilize either steam, boiler water, or high temperature water as the energy source for generating clean steam.

Warranty Information

All components used in Armstrong Unfired Steam Generators are warranted for one (1) year from startup or eighteen (18) months from date of purchase, whichever comes first. In some cases, extended warranties are available on an individual basis, at extra cost.

Contact Information

For information concerning warranty information, or for questions pertaining to the installation, operation, or maintenance of Armstrong Unfired Steam Generators, contact:

Armstrong International, Inc.
816 Maple Street
Three Rivers, MI 49093
www.armstrong-intl.com
USA Phone: (616) 273-1415
USA Fax: (616) 273-9500

To order replacement parts, contact Armstrong International, Inc., at the address listed above.

Note: Please include the model and serial number of the unit for which the parts are being ordered. If ordering by phone, please have this information readily available.

General Notes and Warnings

Notes

- ❖ This manual is intended to cover installation, operation, and maintenance procedures for Armstrong Unfired Steam Generators. Since each unit is built to meet customer specifications, instructions may, at times, seem general in nature. Where procedures differ substantially between steam, boiler water, or high temperature water as the energy source for generating clean steam, specific notes will be given.

If questions are not answered by this manual, or if specific installation, operation, and / or maintenance procedures are not clearly understood, contact Armstrong for clarification before proceeding.

- ❖ All installation, operation, and maintenance procedures should be performed only by experienced, trained, and certified personnel. Personnel should be trained in correct piping and electrical procedures and methods, and should be experienced in working with steam and boiler water / high temperature water systems.
- ❖ Armstrong Unfired Steam Generators are designed for indoor use only, unless otherwise required by design specifications. Each unit requires at least two feet (2') of clearance around and above the unit. It should be located on a level surface (no more than one-half degree [$\frac{1}{2}^\circ$] of slope), capable of supporting the total weight of the unit when filled to capacity.

The unit should be mounted to the floor following applicable architectural and local code requirements for the specific installation site.

In areas prone to seismic activity, it is recommended that the unit be mounted to the floor according to recommended procedures and codes for the site / location, to make the units less susceptible to seismic damage.

- ❖ The high quality enamel paint, applied to the jacket of the unit, will provide years of protection against corrosion. If it is necessary to clean the outside of the unit, a mild cleaning agent should be used that will not damage the paint.
- ❖ Inspection procedures, troubleshooting, and periodic maintenance, as well as suggested intervals, are detailed on pages 40 to 55 of this manual.
- ❖ Armstrong Unfired Steam Generators are available in a wide range of operating pressures. For the specific ranges for your unit, refer to the design specifications and accompanying literature supplied with the unit.

- ❖ If the unit is damaged during installation, operation, or maintenance, complete the following steps.
 1. Turn off the power to the unit.
 2. Turn off the energy source inlet (steam, boiler water, or high temperature water) valve(s).
 3. Turn off the energy source (steam, boiler water, or high temperature water) return valves.
 4. Turn off the clean steam and condensate outlet valves.
 5. Turn off feed water inlet valves.
 5. Contact in-house maintenance personnel or Armstrong for instructions.

- ❖ For all piping connections, the use and / or type of joint compound or sealer on the joints should be determined by referring to local codes, accepted standards, and / or the requirements of the installing contractor.

Warnings

As with any piece of equipment that utilizes steam, boiler water, or high temperature water under pressure, as well as electricity, ***the potential exists for severe personal injury*** if proper installation, operation, and maintenance procedures are not followed. Listed on the following pages are specific warnings pertaining to Armstrong Unfired Steam Generators. In addition, throughout this manual, warnings are restated when procedures are described pertaining to areas of potential danger. ***All warnings should be carefully read and understood.*** All precautions contained in the warnings should be carefully followed to reduce the chance of injury.

Note: Throughout this manual, warnings will be denoted by the symbol ☒.

All documentation for each major component has been included with the unit. It is strongly recommended that each document be reviewed ***before*** attempting any installation, operation, or maintenance procedures.

The documentation for each major component may also contain warnings and cautions identified by the manufacturer of each component. These warnings and cautions may be specific for the particular component, and therefore not covered in this general Installation, Operation, and Maintenance Manual. They should also be carefully reviewed before attempting installation, operation, or maintenance procedures.

- ☒ Areas of potential danger:
 1. all steam / boiler water / high temperature water lines, joints, valves, and pressure regulators;
 2. all steam outlet lines, joints, valves, and pressure regulators;
 3. all power connections and cables; and
 4. all pneumatic (instrument air) lines and joints.

- ☒ Before attempting any installation, operation, or maintenance procedures pertaining to the unit:
 1. assure that the energy source (steam or boiler water / high temperature water) has been turned off at the manual shutoff valve;
 2. if the unit has been in operation, allow the clean steam and water in the tank, as well as all components and surfaces (outlet steam lines, energy source inlet lines, etc.) to cool before starting the procedure;
 3. assure that all power has been shut off / disconnected before attempting any procedures;
 4. assure that all incoming and outgoing steam, condensate, and energy source lines have been turned off at the manual shutoff valves; and
 5. assure that the pneumatic (instrument air) source has been turned off and the pressure bled from the lines.

- ☒ Steam, boiler water, or high temperature water present situations that can be **very dangerous** due to the fact they are under pressure and at very high temperatures. To avoid possible injury or death, use common sense and follow all accepted and recommended procedures when performing installation, operation, and maintenance procedures.

- ☒ The combination of electricity and water can pose a **very dangerous situation**. Assure that all power has been shut off / disconnected before attempting any installation or maintenance procedures.

Product Features and Specifications

Congratulations on purchasing a Armstrong Unfired Steam Generator. The unit purchased will offer years of superior dependable service.

Armstrong Unfired Steam Generators, employing the "U-Bend" heat exchanger coil, are the most economical method of furnishing clean steam when steam, boiler water, or high temperature water are used as the energy source. All Armstrong Unfired Steam Generators are "Packaged" and ready for installation. All components are sized, mounted, piped, and tested prior to shipment. Each unit is built to exact customer design specifications and requires only connection to energy, water, power, and / or pneumatic sources to be ready for operation.

The "Packaging" concept provides a compact size that is ideal for new installations, or for use as replacement of existing steam generators. The compact size requires less space for installation, and makes moving the unit through doorways, work areas, etc., less of a problem.

Each unit employs either a Carbon (Black) or Stainless Steel tank, providing years of trouble free service. All components used in the unit are of highest quality and meet or exceed all customer design specifications and American Society of Mechanical Engineers (A.S.M.E.) Code regulations.

Each Unfired Steam Generator is accompanied by this Installation, Operation, and Maintenance Manual, a detailed Submittal sheet and C.A.D. drawing, as well as all documentation supplied by the manufacturer of each major component. If any of these documents are missing, contact either Armstrong or your authorized sales representative before attempting installation, operation, or maintenance procedures.

Installation

Transporting and Unpacking the Unit

Most Armstrong Unfired Steam Generators are crated, as necessary, at the factory. The crating is designed to provide protection for the unit during transportation, and to provide a safe means by which to lift and move the unit with a fork lift or hand truck. Larger horizontal units are shipped uncrated, but fitted with lifting lugs attached to the tank to provide a safe means for lifting and moving the unit.

- ☒ The unit should only be lifted at the areas indicated on the crate, or by the lifting lugs provided. Improper lifting of the unit may result in damage to the unit.

Location Requirements

Armstrong Unfired Steam Generators are designed for indoor use only, and require at least two feet (2') of clearance around and above the unit, unless otherwise required by the design specifications. The unit should be located on a level surface (no more than one-half degree [$\frac{1}{2}^\circ$] of slope), capable of supporting the total weight of the unit when filled to capacity.

If crated when shipped, once the unit has been set in place, the crating should be carefully removed.

Examining the Unit

After the unit has been set in place and uncrated, it should be carefully examined to assure that neither the main unit nor any of the components have been damaged during shipping. If any evidence of damage is detected that could affect the safe operation of the unit, contact Armstrong International, Inc., or your authorized sales representative, to report the damage and to receive instructions on how to proceed.

After the unit and all components have been inspected for damage, it is suggested that all pressure and control components be checked to assure that they meet or exceed design specifications. This can be done by reviewing the design specifications (included with the unit) and the specification tags / plates attached to each component. If any discrepancy is found (that is below design specifications), contact Armstrong International, Inc., or your authorized sales representative, before proceeding with the installation.

Mounting the Unit

The unit should be mounted to the floor, following applicable architectural / local code requirements, or accepted standards for the specific installation site and for the unit purchased.

In areas prone to seismic activity, it is recommended that the unit be mounted to the floor, according to recommended procedures for the site, to make the units less susceptible to seismic damage.

Familiarization with the Unit and Components

Armstrong Unfired Steam Generators are designed to make installation a relatively simple procedure. Because the unit is "Packaged," after placing and mounting the unit, installation involves:

1. connecting the feed water source to the feed water inlet;
2. connecting the generated clean steam outlet to the clean steam outlet;
3. connecting the energy source (steam, boiler water, or high temperature water) to the unit;
4. connecting the condensate and steam / water return line and piping it to the recycling system;
5. piping the pressure relief valve to an acceptable vent and drain system;
6. wiring the applicable source of power (if the unit is packaged with an electrically activated pressure or control component); and
7. connecting the appropriate instrument (control) air source.

Each unit is supplied with a Submittal sheet and C.A.D. drawings that indicate the location and specifications for each connection that must be made. In addition, the drawings will enable the installer(s) to determine the flow direction of both the steam and energy source.

Connecting the Feed Water Source and Generated Clean Steam Outlet

Note: Before making any connections of feed water inlet or generated clean steam outlet to the unit, assure that all piping is clean and free of foreign material or scale. This can usually be accomplished by "blowing out" the pipe. Any foreign material or scale entering the unit can adversely affect operation and performance.

Feed Water Source

The first step in the installation process is to connect the feed water source to the feed water inlet port. The exact location of this port for the specific unit, as well as inlet pipe diameter and thread size, can be determined from the C.A.D. drawings supplied with the Submittal sheet.

A manual shutoff valve should be installed upstream on the feed water source as an isolation device. Refer to the supplied Submittal sheet and C.A.D. drawing to determine if the feed water is controlled by either a solenoid valve or feed water pump. If so, the shutoff valve must be installed upstream from the valve or pump.

The shutoff valve should be in the closed position and remain so until the installation is complete.

Note: *For all piping connections, the use and / or type of joint compound or sealer on the joint should be determined by referring to local codes, accepted practices, or the requirements of the installing contractor.*

Generated Clean Steam Outlet

The next step in the installation process is to connect the generated steam system piping to the clean steam outlet port. The exact location of this port for the specific unit, as well as outlet pipe diameter or flange size, can be determined from the C.A.D. drawing supplied with the Submittal sheet.

A manual shutoff valve and automatic check valve should be installed downstream on the generated clean steam line as isolation devices in case the unit must be disconnected from the system. The shutoff valve should be in the closed position and remain so until the installation is complete.

Note: *Refer to local codes and specifications for site specific shutoff and check valve requirements. For all piping connections, the use and / or type of joint compound or sealer on the joint should be determined by referring to local codes, accepted practices, or the requirements of the installing contractor.*

Connecting the Energy Source (Steam, Boiler Water, or High Temperature Water)

- ☒ Steam, boiler water, or high temperature water present situations that can be **very dangerous** because of the high temperatures and pressures. Use common sense and follow all accepted and recommended procedures when performing installation, operation, and maintenance procedures to avoid possible injury or death.

Assure that a manual shutoff valve is installed upstream in the steam, boiler water, or high temperature water line (energy source), and that it is functioning properly. If any doubt exists concerning the integrity of the shutoff valve, replace the valve before attempting installation. All energy source valves should be closed and remain closed throughout the installation process.

Connect the energy source to the line(s) leading to the pressure control valve. The exact location of the pressure control valve for the specific unit, as well as energy source pipe diameter and thread size, can be determined from the C.A.D. drawing supplied with the Submittal sheet.

Note: For all energy source piping connections, the use and / or type of joint compound or sealer on the joint should be determined by referring to local codes, accepted practices, or the requirements of the installing contractor.

Connecting the Steam Condensate Line or the Boiler Water / High Temperature Water Return Lines

Steam Condensate Return Line

As the heat is extracted from the energy source and transferred to the clean steam generating system, condensate will form. This condensate must have a means by which it can drain from the unit and return to the steam system. The condensate return line serves this purpose. Do not attempt to lift condensate with float and thermostatic traps.

The condensate return line should be connected to the unit at the condensate return port. The condensate port is normally located downstream from the main and auxiliary traps. The exact location of this port for the specific unit, as well as the condensate return pipe diameter and thread size, can be determined from the C.A.D. drawing supplied with the Submittal sheet. The condensate line should be piped back into the site's steam system for recycling. Do not attempt to lift condensate with a float and thermostatic steam trap.

A manual shutoff valve should be installed downstream in the condensate return line to allow the unit to be isolated from the system. The condensate shutoff valve will prevent back flow of steam or condensate if the line is disconnected.

Boiler Water and High Temperature Water Return Line

After the boiler water or high temperature water has passed through the heat exchanger coil, and the heat has been extracted and transferred to the clean steam generating system, the water must return to the system. The water return line serves this purpose.

The water return line should be connected to the unit at the return port. Unlike the steam condensate return line, the return lines for boiler and high temperature water do not have in-line condensate traps. The return port is normally located downstream from the heat exchanger coil. The exact location of this port for the specific unit, as well as the water return pipe diameter and / or flange size, can be determined from the C.A.D. drawing supplied with the Submittal sheet.

A manual shutoff valve should be installed downstream in the water return line to allow the unit to be isolated from the system. The water return shutoff valve will prevent back flow of boiler water or high temperature water if the line is disconnected.

Piping the Relief Valve to Vent and Drain

All Armstrong Unfired Steam Generators are equipped with a pressure relief valve for the tank. In most applications, the pressure relief valve should be vented to atmosphere (generally through the roof). The piping used in the vent system **must be of adequate size to handle the capacity of the pressure relief valve and vent**. The vent piping system should incorporate a "drip pan elbow" to allow for condensate drainage. The drip pan elbow should be piped to a suitable drain.

Piping the pressure relief valve to a suitable vent and drain will prevent both water and heat damage to the unit, as well as reduce the risk of injury from released steam. All pressure relief venting and piping should comply with local codes. It is the responsibility of the purchaser / installing contractor to assure this compliance.

- ☒ **Do not** install a valve between the pressure relief valve and the vent or in the vent line. Doing so could cause serious injury or death if the pressure is released and the manual valve is closed. This would cause excessive buildup of pressure in the clean steam generator tank which could result in an explosion.

Connecting Electrically Activated Controls

Armstrong Unfired Steam Generators can be equipped with electrically activated pressure and water level control valves. If the unit being installed is so equipped, the correct power source(s) must be connected.

- ☒ The combination of electricity and water can pose a **very dangerous situation**. Assure that all electric power has been turned off before attempting any installation or maintenance procedures.

Reference the wiring C.A.D. drawing that is included with the Submittal sheet, or the installation instructions contained in the Installation Manual for the component, for specific wiring instructions.

Armstrong Unfired Steam Generators are designed so that if a power failure or cutoff should occur, the unit will automatically shutdown. This is accomplished through a "solenoid safety system" incorporated in the unit. The solenoid safety system requires power to operate. If the power supply is disrupted, the solenoid safety system closes the energy source feed valve.

If permitted by local codes, the Unfired Steam Generator can be wired into the site's emergency power system, to allow continued operation during a power failure. Consult

local codes before connecting the unit to an emergency power source to assure compliance.

Note: *All power connections should be performed by trained, certified electricians.*

Connecting Pneumatically Activated Controls

Armstrong Unfired Steam Generators can be equipped with pneumatically activated controls. In most cases where pneumatically activated controls are used, they require instrument air with pressure ranges from 15 to 100 psi. Refer to the supplied C.A.D. drawing, Submittal sheet, and specific installation and operation materials for each component to determine the requirements for that component.

- ☒ Assure that the pneumatic feed line has been shutdown, and air pressure bled from the system by acceptable methods, before attempting any connections.

Reference the C.A.D. drawings that are included with the Submittal sheet, or the installation instructions contained in the Installation Manual for the component, for specific piping instructions.

Note: *For all pneumatic connections, the use and / or type of joint compound or sealer on the joint should be determined by referring to local codes, accepted practices, or the requirements of the installing contractor.*

Connecting the Drain / Blowoff Line

Armstrong Unfired Steam Generators are equipped with a drain / blowoff line. Each generator has one or more manual blowoff valves connected to the bottom of the vessel. The blowoff from these valves is at the pressure and temperature of the generated steam and can cause severe injury or death if not properly piped. It is recommended that the blowoff lines be connected to a Armstrong blowoff (CBO) tank / condensate cooler before being discharged to drain. Check with local codes, accepted practices, or the requirements of the consulting engineer.

- ☒ The blowoff from the unfired steam generator can flash to steam when introduced to atmospheric pressure.

Some unfired steam generators are equipped with automatic blowoff valves. The blowoff from these valves should also be piped to the blowoff tank / condensate cooler as previously described.

The level controller line will have a blowoff valve at the low point for blowing off the level control piping. This valve should also be piped to the blowoff tank / condensate cooler as previously described.

General Notes and Warnings

Notes

- ❖ This manual is intended to cover installation, operation, and maintenance procedures for Armstrong RBCM 2002 control module.

If questions are not answered by this manual, or if specific installation, operation, and/or maintenance procedures are not clearly understood, contact Armstrong for clarification before proceeding.

- ❖ All installation, operation, and maintenance procedures should be performed only by experienced, trained and certified personnel. Personnel should be trained in and familiar with correct piping and electrical procedures and methods, and should be experienced in working with hot/boiler water systems and steam systems.
- ❖ Armstrong RBCM 2002 control module and other electronic controls are designed for indoor use only, unless otherwise required by design specifications.
- ❖ If the unit is damaged during installation, operation, or maintenance, complete the following steps:
 1. Turn off and lock out the electric power supply to the unit in an approved manner.
 2. Turn off all incoming steam/hot water valves.
 3. Contact in-house maintenance personnel or Armstrong for instructions.

Warnings

As with any piece of equipment that utilizes hot/boiler water or steam and electricity, **the potential exists for severe personal injury** if proper installation, operation, and maintenance procedures are not followed. Listed on the following pages are specific warnings pertaining to Armstrong Electronic Controls. **All warnings should be carefully read and understood.** All precautions contained in the warnings should be carefully followed to reduce the chance of injury.

Note: Throughout this manual, warnings will be denoted by the symbol ▼ .

All documentation for each major component has been included with the unit. It is strongly recommended that each document be reviewed before attempting any installation, operation, or maintenance procedures.

The documentation for each major component may also contain warnings and cautions identified by the manufacturer of each component. These warnings and cautions may be specific for the particular component, and therefore not covered in this general Installation, Operation, and Maintenance Manual. They should also be carefully reviewed before attempting installation, operation, or maintenance procedures.

- ▼ The combination of electricity and water can pose a **very dangerous situation**. Assure that all power has been **shut off/disconnected and locked out** in an appropriate manner, before attempting any installation or maintenance procedures.
- ▼ Areas of potential danger:
 1. all electric power leads and connections;
 2. all hot/boiler water lines, steam lines, joints, valves, and relief valves; and
 3. all joints at valve, gauges, etc.
- ▼ Before attempting any installation, operation, or maintenance procedures pertaining to the unit.
 1. assure that the electric power supply has been turned off and locked out in an approved manner;
- ▼ Hot/boiler water and steam present a situation that can be very dangerous due to the fact it is under pressure and at very high temperatures. To avoid possible injury or death, use common sense and follow all accepted and recommended - procedures when performing installation, operation, and maintenance procedures.

Connecting the Electric Power Source

- ▼ All installation procedures involving electric power connection should only be performed by trained, certified electricians.
- ▼ Hot/boiler water and steam present a situation that can be very dangerous because of the high temperatures and pressures. Use common sense and follow all accepted and recommended procedures when performing installation, operation, and maintenance procedures to avoid possible injury or death.
- ▼ The combination of electricity and water can pose a very dangerous situation. Assure that all power has been shut off/disconnected and locked out in an approved manner, before attempting any installation or maintenance procedures.

The Armstrong Steam Generators have been wired during assembly. Connecting the - electric power supply to the unit consists of connecting the correct voltage, phase, and amperage power leads to the terminal strip or circuit breaker. The exact voltage, phase, and amperage requirements for the unit can be determined from the rating plate affixed to the jacket of the unit, or from the Submittal Sheet and Wiring Diagrams supplied with the unit.

The Controller - Overview

Armstrong RBCM 2002 control module is a solid state controller designed to control limit, water feed, alarm, and timed blowdown functions for Armstrong unfired steam generators.

The Solid State Control Module is supplied with a LED backlit LCD display. LED pilot lights are supplied to indicate On-Off, high pressure, low pressure, low water, high water, water feed, and blow down. The solid state control module allows the owner to set pressure limits on the display screen. The solid state control module has a flashing red alarm light and alarm horn with built in alarm silence relay. The solid state control module is supplied with dry contact closure outputs to indicate to building automation control (BAC) Power on, Low water, High pressure, Water feed, High water, Low pressure and Blow down occurring. The control module allows the BAC to turn the Unfired Steam Generator on or off through a remote relay suitable for 24 VAc, 1 amp. The control module allows the BAC to remotely monitor the operating pressure. The control module is supplied with an on-off switch and is mounted in a NEMA 4 enclosure.

Built in remote start stop: This feature allows the Unfired Steam Generator to be started or stopped from a remote location. Typically this would be accomplished from the Building Automation Control (BAC). Requires a dry contact suitable for 24 VAc and 1 amp. Terminals P2 on the panel are where the BAC on-off is wired.

Built in On-Off Switch: Allows for local on-off and is convenient for service in the unlikely event service is required. This switch is mounted in the side of the panel.

Built in Alarm Horn: The alarm horn will sound and fault LED will light (blinking red) on low water or high pressure. If either high water or low pressure options are selected the alarm horn will also sound and the alarm light will light (blinking red) in the event of high water or low pressure. The 2002 RB Control Module also features an alarm silence relay which will silence the alarm but not the fault light when the generator is being serviced. When the fault is cleared both the alarm and fault light will automatically reset.

Built in timer for timed blow down: If the timed blowdown option is selected the time and duration of blow down can be easily selected in the 2002 RB Solid State Control Module.

Built in relay for water feed: the Armstrong 2002 RB Solid State Control Module operates in conjunction with the level control to signal the feed water solenoid or feed water pump to maintain the correct water level in the unfired steam generator.

Built in operating pressure readout: The 2002 RB Control Module features an easy to read LED digital readout of the operating pressure.

Built in high pressure cut off and alarm: In the event of high pressure the 2002 RB Solid State Control Module will close the source steam or HTHW supply valve and sound an alarm.

Built in low water cut off and alarm: In the event of low water the 2002 RB Solid State Control Module will close the source steam or HTHW supply valve and sound an alarm.
 Built in low pressure alarm: If activated, the 2001 Solid State Control Module will sound an alarm if a low pressure condition occurs.

Built in optional input / output.

Built in LED display of functions and alarms: The 2002 RB Solid State Control Module is designed for the user to tell at a glance how the system is operating. The built in LED displays make troubleshooting simple.

Function	LED Indicator 1	LED Indicator 2
Power ON	Green = Power On	Blank = No power
Low water	Green = Water level not low	Red = Low water
High pressure	Green = Normal pressure	Red = High pressure
Water feed	Green = Water feeding	Blank = Water not called for
High water	Green = Water level normal	Red = High water
Low pressure	Green = Pressure not low	Red = Low pressure
Blow down operating	Green=Blowdown occurring	Blank = No blowdown
Optional input/output		

Built in contacts to notify BAC (Reliable interface with the BAC via dry contact closures so the BAC can monitor the unfired steam generator building) of functions and alarms: This control allows for simple and from a remote location. The BAC can also start and stop the unfired steam generator.

Power ON
Low water
High water
Water feed
High pressure
Low pressure
Blow down operating
Optional input / output
Alarm
Operating pressure (via a 0-10 Vdc signal)

Contractor Wiring

All Power Connections should be performed by a trained , certified electrician. Be sure the factory supplied on-off switch is in the OFF position before connecting to building power.

Field wiring: Installer must run feed wires to terminals on panel mounted on-off disconnect switch and green ground wire to ground lug. *Units are normally wired for 120 volt single phase input.*

Warning: Before drilling hole in panel for conduit connection of power carefully open door and verify that nothing in panel will be interfered with. BE CAREFUL not to get any drill shavings or metal slug on board or transformer or disconnect switch.

Panel is normally factory shipped for 120 Volt/ 1 phase/60/50 Hz. If so desired 220/1/50 or 60 Hz power can be used. To convert to 220 volt input it is necessary to reconfigure the 24 volt output transformer. Below is the wiring diagram for 120 volt and 220 volt input.

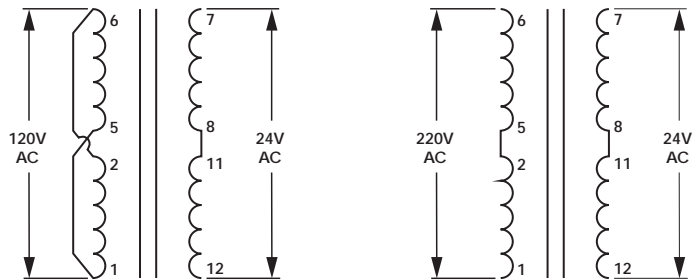

▼ **CAUTION:** Before attempting to rewire the transformer be sure power coming to the unit is turned off and locked out in an approved manor.

Ratings

Input: selectable 120/220 VAC – 50/60 Hz
 @120 Vac min 90 volt max 130 volt
 Output Contacts: 1 amp at 24 Vac
 Building Automation outputs: Dry contacts,
 NO/NC .5 amp maximum, non inductive
 Display: LED display with resolution of
 .3 % of scale
 Available pressure ranges: 0-30 PSI,
 30 – 150 PSI in 10 PSI increments
 Operating ambient temperature: Min 32 °F
 max 140 °F
 Operating Humidity: 5% to 95% relative
 humidity (RH) non condensing
 Alarm approximately 103 db.
 NEMA 4 enclosure

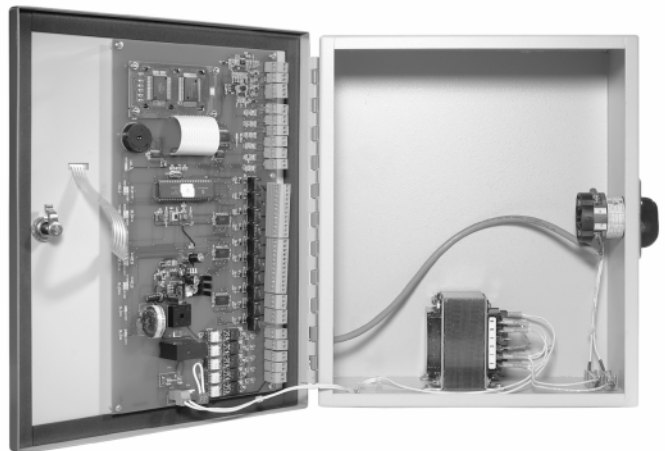

The Armstrong RBCM 2002 is a self contained board and can not be field repaired. For a replacement board contact Armstrong International, Inc. at the address shown on page 4 of this manual.

Controller Screens

Controller screens:

There are two tactile keys on the front of the panel. The left key, labeled NEXT, is pushed to select the desired function. The right key, labeled SELECT, is pushed to access the desired screen. Both the function and setting are read on the LED backlit LCD display.

Pushing the left key will display, in sequence, the following screens :

Next

Select

Screen 1 (Home)

Mode	[Normal]
Pressure PSI	[XXX]

Screen 2

B-Down Duration

Screen 4

B-Down Interval

Screen 5

High Pressure

Screen 5

Low Pressure

Screen 6

Differential

Screen 7

Pressure Sensor

Screen 8

Level Control

Screen 9

Initial Settings

Screen 10

Diagnostics

Screen 11

About

Screen 12

Quit

After 60 seconds in any screen "Home" screen will be displayed

Setting the Controller

Setting the controller

There are two tactile keys on the front of the panel. The left key, labeled NEXT, is pushed to select the desired function. The right key, labeled SELECT, is pushed to access the desired screen. Both the function and setting are read on the LED backlit LCD display. The sequence to access and change any screen is as follows:

1. Press “NEXT” (left key) key until desired function appears on the screen.
2. Press “SELECT” (right key) and a setting will appear on the second line of the screen.
3. Press “NEXT” key to change setting. Continue pressing “NEXT” key, which will scroll through available settings until desired setting is on screen.
4. Press “SELECT” key which will store last screen setting into memory and return to controller screen to “HOME”

Instructions for setting each screen:

Home Screen

This is the screen which should be displayed during normal operation:

Screen 1 (Home)

Mode	[Normal]
Pressure PSI	[XXX]

MODE can be either NORMAL or ALARM. The mode will read normal in normal operation and alarm if any alarm condition occurs. If an alarm condition is cleared the mode will switch back to normal reading.

Pressure psi: This is the pressure of the generated steam.

Timed Blow down

If timed blow down is an option which was purchased the duration and interval of the blow down can be selected. Duration is the length of time the blow down occurs (in seconds) and interval is the number of hours between blow downs.

To set the duration of blow down:

1. Press the NEXT key once and the following screen will appear

Screen 2

B-Down Duration

2. Press the SELECT key and the screen will read.

Screen 2

B-Down Duration

Seconds [XXX]

3. Press the NEXT key to scroll through the various seconds settings until the desired number of seconds of blow down appears on the screen. The seconds will read 0-250 seconds in 10 second increments.
4. Press SELECT key to place setting in memory and to return to home screen.
NOTE: To disable the timed blow down set duration to zero (0)

To set the interval:

1. Press the NEXT key twice and the following screen will appear:

Screen 3

B-Down Interval

2. Press the SELECT key and the screen will read:

Screen 3

B-Down Interval

Hours [XXX]

3. Press the NEXT key to scroll through the various hour settings until the desired number of hours between blow downs appears on the screen. The hours will read 0-30 hours in one hour increments and 40 through 160 hours in 10 hour increments.

4. Press SELECT key to place the setting in memory and return to home screen.

NOTE: To disable the timed blow down set interval to zero (0)

High pressure cut out

This is the pressure limit which is set 10-20% higher than the desired operating pressure. When the high pressure cut out pressure is reached the controller will cause the main control valve to close.

▼ **CAUTION:** The operating pressure is set by the control valve controller, see USG IO & M manual for setting the operating pressure.

1. Press the NEXT key three times and the following screen will appear:

Screen 4

High Pressure

2. Press the SELECT key and the screen will read:

Screen 4

High Pressure Cut Off PSI [XXX]

3. Press the NEXT key to scroll through the pressure settings until the desired pressure setting appears on the screen.. The settings from 0-50 psi are in 1 psi increments and from 50 through 150 psi in 5 psi increments. NOTE: THE MAXIMUM SETTING IS LIMITED BY THE RANGE OF THE PRESSURE SENSOR. **The high pressure setting should be set lower than the relieving pressure the ASME relief valve supplied with the generator.** The pressure rating of the relief valve is labeled on the relief valve body.

4. Press SELECT key to place the setting in memory and return to the home screen.

Low pressure alarm

If desired a low pressure alarm can be set. This will alarm if the generated steam pressure falls below the low pressure setting.

To set the low pressure alarm:

1. Press the NEXT key four times and the following screen will appear:

Screen 5

Low Pressure

2. Press the SELECT key and the screen will read:

Screen 5

Low Pressure
Alarm PSI [XXX]

3. Press the NEXT key to scroll through the pressure settings until the desired low pressure setting appears on the screen.. The settings from 0-50 psi are in 1 psi increments. The maximum low pressure setting is equal to the high pressure setting set on screen 4.
4. Press SELECT key to place setting in memory and return to home screen.

NOTE: To disable the low pressure alarm set the pressure to zero (0).

High and low pressure reset differential

This is the pressure differential from the set point at which the high or low pressure will reset. Normally it is set at 2 psi but can be set from 1 to 10 psi. NOTE: There is only one differential setting and it will be the same for both high and low pressure.

To set the pressure differential:

1. Press the NEXT key five times and the following screen will appear:

Screen 6

Differential

2. Press the SELECT key and the screen will read:

Screen 6

Differential Reset PSI [XXX]
--

3. Press the NEXT key to scroll through the psi settings until the desired psi differential is displayed.. The range is 1-10 psi.
4. Press the SELECT key to place setting in memory and return to the home screen.

Setting Pressure Sensor Range

The pressure sensor supplied with the Unfired Steam Generator will have a specific range, normally 0-30 psi or 0-60 psi or 0-150 psi. **It is extremely important that the range of the pressure sensor and the range listed in the solid state controller be the same range.** The generator is factory shipped with matched ranges. The range of the sensor will be printed on the body of the sensor. The range of the controller can be determined and if necessary changed as follows:

1. Press the NEXT key six times and the following screen will appear:

Screen 7

Pressure Sensor

2. Press the SELECT key and the screen will read:

Screen 7

Pressure Sensor Range PSI [XXX]

3. Verify that the psi range shown is equal to the range of the supplied sensor. The range shown on screen is the upper end of the range. 0-30 will appear as 30 on the screen, 0-60 will appear as 60 on the screen , etc. **IF AND ONLY IF** the range of the sensor is different than the screen setting should the screen setting be changed. To change the screen setting press the NEXT key to scroll through the various pressure settings. Available ranges are 30-150 psi in 10 psi increments. When the desired pressure range appears on the screen verify that this matches the pressure of the sensor.

4. If both pressures match press the SELECT key to place the setting in memory and return to home screen

Level control type

There are two types of level controllers, either one of which may be supplied with the Unfired Steam Generator. The first type is a 4 ball float assembly type mounted in a stainless steel body with a shape as shown below. This is TYPE [0]. The second type is a one ball float type with multiple switches in a cast iron body with a shape as shown below. This is TYPE [1].

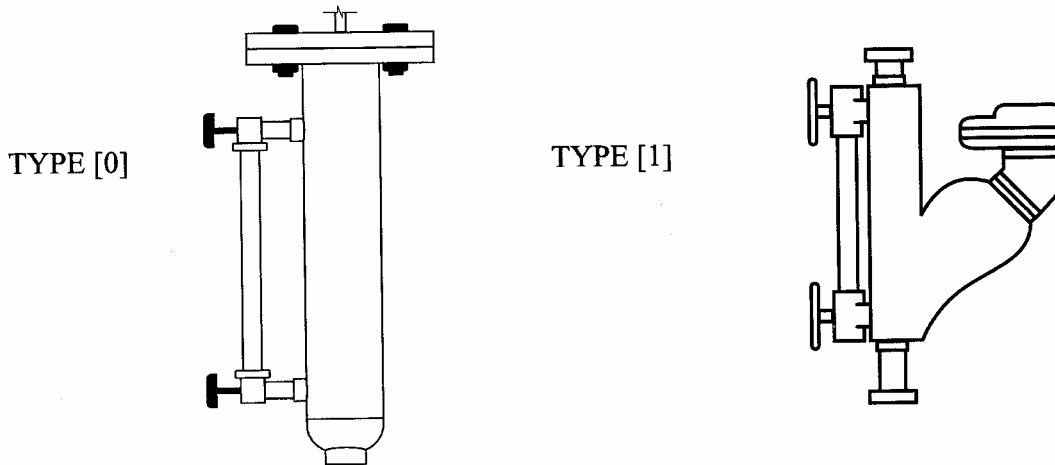

It is extremely important that the type of level control supplied and type listed in the solid state controller be the same. The generator is factory shipped with matched types.

1. Press NEXT key 7 times and the following screen will appear:

Screen 8



2. Press SELECT key and the screen will read:

Screen 8

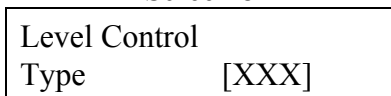

3. Verify that the type listed on screen and type supplied on Unfired Steam Generator are the same. IF AND ONLY IF the type of level control is different than the screen setting should the screen setting be changed. To change the screen setting press the NEXT key to scroll through the two types.
4. If both types match press the SELECT key to place the setting in memory and return to the home screen

Initial Settings

The initial settings are for factory use only and can not be accessed

Diagnostics

Are used for factory testing and are not field useable. To go to “home” screen press Alarm Silence.

Screen 10

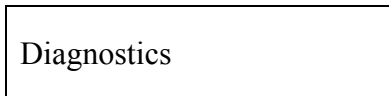

About

This screen lists the version of the controller. When contacting the factory about the controller be sure to mention the version.

1. Press the NEXT key 10 times and the following screen will appear:

Screen 11



2. Press the SELECT key and the screen will read:

Screen 11



3. Be sure to note the version when contacting the factory.

4. Press the SELECT key to return to the home screen.

Quit screen

This screen is **only** used to return to the home screen

1. Press NEXT key eleven times and the following screen will appear:

Screen 12



2. Press Select key and the program will return to the home screen

Note: After 60 seconds in any screen “home” screen will be displayed

Terminal Board Layout

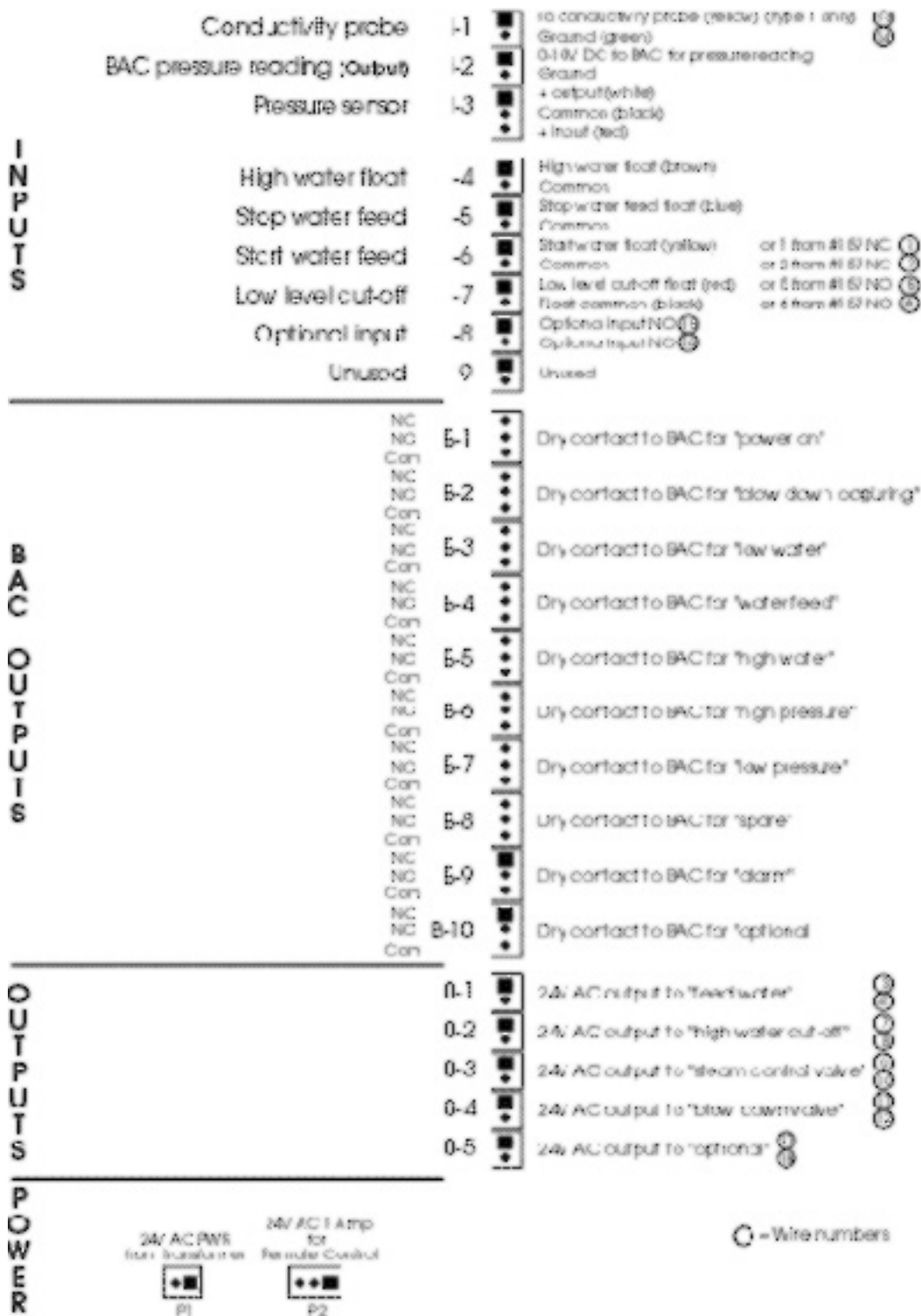

Building Automation Control (BAC) Interface

The Armstrong RBCM 2002 has built in contacts to interface with the building automation control (BAC).

Remote On-Off:

Terminal block P-2 is a three pole block with the two outside poles connected in series with the 24 VAc incoming power from the supply transformer. The Unfired Steam Generator is shipped with a jumper installed between terminals 1- 3 of terminal block P-2. To wire for remote on-off remove this jumper and install a switch or relay contacts connecting terminals 1 and 3. Do not connect anything to terminal 2 of P-2.

▼ **CAUTION: TERMINALS 1 -3 ARE 24 VAC AND WILL HAVE A LOAD OF 1 AMP. BE SURE THE SWITCH OR RELAY CONNECTED TO THESE TERMINALS IS RATED FOR A MINIMUM OF 24 VAc 1 AMP.**

Built in contacts to notify BAC of functions and alarms: This control allows for simple and reliable interface with the BAC via dry contact to enable the BAC to monitor the following functions from a remote location:

Power ON
Low water
High water
Water feed
High pressure
Low pressure
Blow down operating
Optional input / output
Alarm

Refer to the “Terminal Board Layout” page of this manual for the key to and location of terminal connections to the BAC. Note that all of the function relays give either a COM-NO or COM-NC dry contact output. The rating of the dry contacts are 1 amp at 24 VAc or .5 amp at 120 VAc.

▼ **CAUTION: Do not connect any voltage above 120 volts across the BAC contacts on terminal block.**

Contact closure as follows:

Power ON	COM - NO contact made when power is on
Low water	COM - NO contact made when in low water condition
High water	COM - NO contact made when high water occurs
Water feed	COM - NO contact made when water is feeding
High pressure	COM - NO contact made when high pressure occurs
Low pressure	COM - NO contact made when low pressure occurs
Blow down operating	COM - NO contact made when blow down occurs
Optional input	COM - NO contact made when optional contact close
Alarm	COM - NO contact made when any alarm occurs

Operating pressure (via a 0-10 Vdc signal);

Terminal block I-2 will output a 0-10 VDC signal. This signal will be scaled to the pressure range of the supplied pressure sensor. To scale the BAC : Determine the the pressure range printed on the body of the supplied sensor and scale the 0-10 Vdc output signal to this range. This range should also be listed in the submittal supplied for the generator.

- ▼ **CAUTION: The bottom terminal of I-2 is connected to an isolated chassis ground. This may interfere with the BAC system. BAC engineering should determine if BAC needs isolation for this signal.**

- ▼ **CAUTION: No current should be applied to terminals I-2.**

Completing Installation

Installation of the Armstrong Unfired Steam Generator is now complete. All documentation supplied with the unit should be passed along to maintenance personnel for future reference.

Operation

After all installation procedures have been completed, and all clean steam, feed water, energy source, pneumatic joints, and power connections have been double checked, the unit is ready for operation. As a precaution, it is strongly suggested that the following startup and shutdown procedures be followed.

Startup Procedures

1. Assure that all manual shutoff valves on clean steam, feed water, energy source, and pneumatic lines are closed.
2. Because the unit is equipped with a level controller, the power and pneumatic (instrument air) sources should be turned on to allow the controls to regulate filling operations.
3. Slowly open the manual shutoff valve on the feed water inlet line, checking to assure that there are no leaks at the valve or any joints. During initial filling, hold the pressure relief valve open to allow air to bleed out of the tank. This will speed the filling process.
4. The filling process should stop automatically when the correct water level has been reached. This can be verified via a gauge (level) glass located in the water column of the level controller. The filling process should stop when water is visible in approximately the bottom one-third (1/3) of the gauge glass.

If the filling process stops before water is visible in the gauge glass, or before it fills the bottom third of the gauge glass, consult page 49 of this manual for instructions. If the filling process does not stop by the time one-half (1/2) of the gauge glass is filled, shut off the feed water control valve, and turn off the power and instrument air sources. After turning off the feed water, power, and instrument air, consult page 49 of this manual for instructions.

If the unit has filled to the correct level, proceed to the next step.

5. Adjust the operating pressure control to the desired operating pressure. See the Submittal Sheet and the operating pressure control component manual, included with the unit, for the exact location of the control and detailed adjusting procedures.
6. Set the high pressure limit at five to ten pounds per square inch (5 to 10 psi) above the desired operating pressure. See the Submittal Sheet and the high pressure control manual, included with the unit, for the exact location and detailed adjusting procedures.

7. Open the steam condensate return valve or boiler water / high temperature water return valve.
8. Slowly open the manual shutoff valves on the power source inlet and clean steam outlet lines, and create a load / demand situation of approximately ten to twenty-five percent (10% to 25%) of the system design conditions. As the valves are being opened, check for leaks at all valves and joints. For pneumatically controlled valves, open the instrument air supply valve.

Note: *This procedure is similar for both boiler water or high temperature water energy sources.*

- Steam, boiler water, or high temperature water present situations that can be **very dangerous** because of the high temperatures and pressures. Use common sense and follow all accepted and recommended procedures when performing installation, operation, and maintenance procedures, to avoid possible injury or death.
9. If no leaks are found, slowly continue to open the manual shutoff valves on the power source inlet and clean steam outlet.
10. As the unit is initially heating the water and creating clean steam, carefully reinspect the feed water inlet, clean steam outlet, power source inlet (steam, boiler water, or high temperature water), and condensate return lines and joints for signs of leakage.
11. As unit approaches the desired operating pressure, check that the pressure within the unit is within the desired range. If necessary, readjust the pressure control valve. See the Submittal sheet and the pressure control valve component manual, included with the unit, for the exact location of the valve and detailed adjusting procedures.
12. After the unit has reached operating pressure, reinspect all joints for signs of leakage. In addition, check all gauges and controls to verify that the clean steam and energy source pressures are within design specifications.
13. The unit is now ready for normal operation.

Shutdown Procedures

1. Close all valves in the energy source inlet line (steam, boiler water, or high temperature water).
2. Turn off all power to the electric controls, if so equipped.
3. Turn off the pneumatic (instrument air) source.

4. Where possible, relieve the pressure from the energy source line (steam, boiler water, or high temperature water), between the shutoff valve and the unit.
5. Close all remaining valves in the system in this order:
 - the clean steam outlet line;
 - the feed water inlet line; and
 - the condensate return line (or boiler / high temperature water return line).
6. Relieve the pressure within the unit by means of the pressure relief valve and vent system.
7. After the system has cooled, drain the unit by opening the tank drain valve and holding the pressure relief valve in the open position. This will prevent the formation of a vacuum and to the increase the drainage flow.
8. Proceed with the required maintenance or repairs.
9. After performing the required maintenance or repairs, return the unit to operation by following the startup procedure detailed on page 32.

Daily Operation - Standard Unfired Steam Generator

The clean steam and energy source pressures should be checked at the respective pressure gauges **at least twice a day**.

Depending on the options purchased with your Armstrong Unfired Steam Generator, two (2) additional procedures may be required on a daily basis: blowdown and feed water makeup. If the unit has been equipped with an Automatic Feed Water Makeup System or Automatic Blowdown Timer and TDS Sampling System, these procedures are automated and need not be carried out by operating personnel.

Blowdown

Armstrong Unfired Steam Generators are equipped with a drain / blowoff line. Each generator has one or more manual blowoff valves connected to the bottom of the vessel. The blowoff from these valves is at the pressure and temperature of the generated steam and can cause severe injury or death if not properly piped. It is recommended that the blowoff lines be connected to a Armstrong blowoff (CBO) tank / condensate cooler before being discharged to drain. Check with local codes, accepted practices, or the requirements of the consulting engineer.

- The blowoff from the unfired steam generator can flash to steam when introduced to atmospheric pressure.

Some unfired steam generators are equipped with automatic blowoff valves. the blowoff from these valves should also be piped to the blowoff tank / condensate cooler as previously described.

The level controller line will have a blowoff valve at the low point for blowing off the level control piping. This valve should also be piped to the blowoff tank / condensate cooler as previously described.

The buildup of scale and dirt within the unit can effect operation and shorten the life of the unit. The unit should be blown down a **minimum of once a day**. To blowdown the unit:

1. Slowly open the blowdown valve located on the bottom of the unit.

Steam and high temperature water present situations that can be *very dangerous* because of the high temperatures and pressures. Use common sense and follow all accepted and recommended procedures when performing blowdown activities. Failure to do so could result in possible injury or death.

2. Observe the stream of water exiting the blowoff tank / condensate cooler. If scale or dirt is evident in the stream, allow the unit to continue to drain until the water runs clear.
3. Close the blowdown valve.
4. If the unit is not equipped with an automatic feed water makeup system, follow the procedure detailed below to restore the desired water level within the unit. If the unit is equipped with an automatic feed water makeup system, the water level within the unit will automatically return to the proper level. The water level can be checked via the gauge glass located on the water column of the level controller.

The frequency of necessary blowdown is directly effected by the minerals, chemicals, and contaminants contained in the feed water. **Depending on the water, the blowdown interval may need to be altered (either more or less frequently) for each site.**

Feed Water Makeup

Armstrong International, Inc., Unfired Steam Generators are equipped with a level controller which will activate a feed water valve or feed water pump to maintain the correct water level in the generator. The level controller will feed water to the generator when the level falls to a preset level and will stop feeding water when the water level reaches a higher preset point. Normally there is a one to one and a half inches (1" - 1½") water level change in the fill cycle.

The level controller also has a low water cut off position which will activate if the water falls approximately one inch (1") below the water fill position. If a low after condition occurs, the control valve for source steam will be closed and, if furnished, the alarm will sound.

- ☒ Steam and high temperature water present situations that can be *very dangerous* because of the high temperatures and pressures. Use common sense and follow all accepted and recommended procedures when examining water level by means of the tricocks. Failure to do so could result in possible injury or death.

Note: As the feed water level is being raised, pressure may be released from the pressure relief valve to the atmosphere.

The feed water level should be checked **a minimum of twice a day**.

Daily Operation - Unfired Steam Generator with Optional Equipment

No matter what optional equipment was included with the unit, the clean steam and energy source pressures should be checked at the respective pressure gauges **at least twice a day**.

The optional equipment available with Armstrong Unfired Steam Generators includes:

- Alarm Bell;
- Remote Control;
- Automatic Blowdown Timer; and
- Automatic Blowdown TDS Sampling System.

The following is a short description of their function.

Alarm Bell

The alarm bell circuit sounds an alarm bell if the water level drops below a set level or if the pressure within the system exceeds the set limit. The alarm bell

itself can be turned off, but a red warning light will remain lit until the detected condition is remedied.

Remote Control

The Unfired Steam Generator can be fitted with a remote control that typically would activate or deactivate the solenoid controlling the control valve. This in effect would turn the unit on or off.

Automatic Blowdown Timer

The automatic blowdown timer is a seven (7) day, twenty-four (24) hour timer, by which the blowdown schedule can be set. It can be set in frequencies as close as every two (2) hours and as far apart as once every seven (7) days. The main timer signals an interval timer that determines how long the blowdown will be. The interval timer can be set for durations of two (2) seconds to one-hundred eighty (180) seconds.

Automatic Blowdown TDS Sampling System

The Automatic Blowdown TDS Sampling System serves two (2) purposes. First, it acts as a normal Automatic Blowdown Timer. Second, it samples the blowdown water and measures the level of solids (scale, dirt, chemicals, etc.) contained in the blowdown water. If excess amounts of solids are detected, the system will keep the blowdown valve open until the level of solids detected in the water is within acceptable levels.

As can be seen from the preceding descriptions, the optional equipment available can directly affect the normal daily operation of the unit by automating many of the tasks.

Parts List

Replaceable Parts List

The following is a list of parts that are generally replaceable, by trained / certified personnel, on Armstrong International, Inc., Unfired Steam Generators. The replaceable parts may vary, depending on the unit and the particular design specifications to which the unit was constructed. If there are questions concerning the replaceable parts for the unit, refer to the original design specifications, or contact Armstrong International, Inc.

Please have the unit's model and serial number available when contacting Armstrong.

Replaceable Parts Armstrong Unfired Steam Generators - Vertical and Horizontal

Note: Replaceable Parts may vary depending on design specifications of the unit.

Control Valve - Pressure
Gaskets - Coil
Heat Exchanger Coil
Level Controller
Pressure Gauge - Clean Steam
Pressure Gauge - Energy Source Steam
Relief Valve - Pressure
Solenoid Safety System
Strainer
Trap - Auxiliary
Trap - Main

Suggested Spare Parts

For One (1) Year of Duty

Because of the built-in quality and long life of Armstrong Unfired Steam Generators, there are no spare parts suggested for stock during the first year of service.

For Five (5) Years of Duty

It is recommended that the user stock a replacement heat exchanger coil unit and gaskets for possible replacement during the first five (5) years of duty. If suggested maintenance procedures are performed, the heat exchanger coil should not need to be replaced during the first five (5) years of duty.

For the replacement heat exchanger coil model number, refer to the nameplate mounted on the jacket of the unit.

Ordering Information

All replacement parts for Armstrong Unfired Steam Generators can be ordered through your local Armstrong Representative. If you are unsure who your local factory representative, please contact us for help in locating them.

Armstrong International, Inc.
P. O. 408
Three Rivers, MI 49093
www.armstrong-intl.com

Phone: (616) 273-1415
Fax: (616) 273-9500

Please include the model and serial number of the unit for which the parts are being ordered. If ordering by phone please have this information readily available.

Inspection

The following table summarizes the recommended time intervals for inspections of the Unfired Steam Generator, components, feed water inlet, clean steam outlet, energy source lines (steam, boiler water, or high temperature water), and power and pneumatic connections.

Recommended Inspections

Time Interval

To Be Inspected	Per Manu. Specs.	Daily	Weekly	Monthly	Quarterly	Semi- Annually	Annually	Bi- Annually
Blowdown		✓ minimum						
Control Valves - Pressure	✓							
Feed Water Level		✓ minimum						
Gauges - Pressure					✓			
Heat Exchanger Coil & Gaskets								✓
Level Controller	✓ minimum							
Lines - Inlet, Outlet, & Return					✓			
Pneumatic Connections					✓			
Power Connections					✓			
Pressure - Clean Steam & Energy Source		✓ minimum						
Pressure Relief Valve	✓							
Shutoff Valves - Manual			✓					
Solenoid Safety System						✓		
Strainers					✓			
Traps - Main & Auxiliary							✓	

If any problems are detected during inspections, refer to either the Troubleshooting (page 41) or Maintenance (page 44) sections of this manual for specific actions and instructions.

Troubleshooting

The following table summarizes problems that may be encountered over the life of a Armstrong Unfired Steam Generator, and the procedures to remedy those problems. The left-hand column lists the symptoms. The remaining columns are suggested procedures or "remedies" that should be followed to identify and correct the problem. If a "✓" appears in a remedy column, the corresponding procedure(s) should be followed to identify and correct the problem.

Symptom	Probable Cause and Remedy #										
	1	2	3	4	5	6	7	8	9	10	11
Unfired Steam Generator does not maintain the required pressure at the rated capacity.	✓	✓	✓			✓	✓		✓	✓	
Feed water level incorrect or inconsistent.											✓
Outlet pressure is too high.	✓		✓		✓		✓				
Outlet pressure fluctuates widely.		✓	✓		✓		✓		✓		
Excess or insufficient condensate (steam, boiler water, or high temperature water) being returned from the unit.			✓								
Steam being discharged into the condensate drain.										✓	
Pressure relief valve "pops".					✓		✓	✓			
Unfired Steam Generator shuts down at or too close to (above or below) the design clean steam outlet pressure.								✓			
A loud banging in the Unfired Steam Generator, primary piping, or condensate / water return piping (not to be confused with a normal clicking noise made during operation).			✓	✓							

Probable Cause and Remedy

1. The pressure gauge is not correctly sensing the clean steam pressure.
 - Check the clean steam pressure with a pressure gauge that is known to be correct. Replace the pressure gauge if it is found to be incorrectly sensing the clean steam pressure. (Reference pressure gauge replacement procedure on pages 51 and 52.)

2. Inlet energy source pressure is too low.
 - Check the primary energy source pressure gauge. If the reading is low, adjust the inlet pressure to meet the design requirements. If there is a restriction in the primary energy source line, the gauge reading will drop

excessively when the generator calls for full energy, even though the pressure seems to be normal during light demand. If the primary pressure is correct, its pressure gauge reading should reach design pressure for energy source in the coil as the pressure in the unfired steam generator approaches shutoff.

3. The condensate / water return piping has not been installed properly, allowing the condensate / water to drain freely (by gravity); the condensate / water drain line is restricted; or the condensate / water check valve is leaking or has failed.
 - Reconfigure the condensate / water return piping and check valve to allow for proper drainage. Check to assure that there is no restriction in the condensate / water drain line. Replace the check valve if it is leaking or has failed. Also, check to assure that there is no restriction in the condensate / water drain line.
4. Primary / inlet steam line is not properly trapped (steam as energy source only).
 - Reconfigure the primary / inlet steam line to allow main and auxiliary (drip) traps to function properly.
5. The primary / inlet pressure control valve is not closing properly.
 - See the adjustment and testing instructions contained in the supplied Installation / Operations Manual for the specific temperature control valve installed on the unit. Replace the valve if necessary. (Reference replacement procedure on page 55.)
6. The primary / inlet pressure control valve is not opening properly.
 - See the adjustment and testing instructions contained in the supplied Installation / Operations Manual for the specific temperature control valve installed on the unit. Replace the valve if necessary. (Reference replacement procedure on page 55.)
7. The energy source pressure control system is not operating properly.
 - See the adjustment and testing instructions contained in the supplied Installation / Operations Manual for the specific pressure control system installed on the unit. Replace the valve if necessary. (Reference replacement procedure on page 55.)
8. The over-pressure limit system is out of adjustment, or some component of the system has failed.

- Check the individual components of the system and repair or replace the failed component(s) as necessary.
9. There is a leak in the heat exchanger coil or the condensate / water return line causing water to leak from the tank or energy source system.
- To verify the existence of a leak, shut off the primary energy source to the unit and carefully break a connection in the condensate / water return line.

CAUTION: The system still contains the primary energy source, possibly under pressure, and could present a serious potential for injury. Use extreme caution when breaking any connection in the system.

Energy source steam condensate or boiler / high temperature water will drain from the coil initially, but the flow should stop after a short period of time. If the flow continues, water is leaking from the tank into the coil. Disassemble, inspect, repair (if possible), or replace the heat exchanger coil and reassemble the unit. (Reference heat exchanger coil replacement procedure on page 45.)

10. The heat exchanger coil is heavily scaled or damaged.
- Call Armstrong, or an authorized sales agent, for instructions on repair or replacement. Refer to the nameplate for the model and serial numbers of the unit and heat exchanger coil. **Include these numbers in all correspondence.**
11. The level controller is not functioning correctly or the floats within the controller have not retained their original position.
- Shut down the system following the shutdown procedures on page 33. Follow the maintenance procedures on page 49 to remove the level controller and to check for correct float positioning. Readjust the floats if they are determined to be out of position, or replace the level controller if found to be defective.

Maintenance

The information contained in this section will detail service and maintenance procedures for the inspection and replacement of the components of Armstrong Unfired Steam Generators. Remember, this manual serves all Armstrong Unfired Steam Generators. Therefore, the maintenance procedures may be general in some instances. If there are any questions concerning maintenance procedures that are not clearly explained in this manual, contact Armstrong International, Inc. Be sure to have the model and serial numbers of the unit and heat exchanger coil available before making contact.

Note: *Many of the maintenance procedures detailed in this section will require the unit to be taken off-line before the procedure is performed; and put back on-line after the procedure is completed. It is recommended that the maintenance personnel performing these procedures review the startup and shutdown procedures, detailed on pages 32 and 33 of this manual, before attempting any maintenance procedure.*

Any component(s) directly connected or linked to the component being replaced should carefully be examined before maintenance procedures are started. If any of the related components show signs of wear or improper operation, they should be considered for replacement at the same time.

Power Connections - Rewiring

If any of the power connections must be rewired at the electrically activated controls or junction boxes, follow the steps listed below.

- ☒ The combination of electricity, steam, and water can pose a **very dangerous situation**. Turn off / disconnect all electric power before attempting any maintenance procedure.
- 1. Follow Steps 1 through 6 of the shutdown procedure (page 33) to take the unit off-line before attempting any electrical service.
- 2. After assuring the power has been turned off, disconnect and rewire the electrical connections in question.
- 3. Turn the power on and check that the component that has been rewired is functioning properly.
- 4. Follow the startup procedure on page 32 of this manual to return the unit to operation.

Pneumatic (Instrument Air) Connections - Refitting

If any of the pneumatic (instrument air) connections must be refit at the pneumatically activated controls, follow the steps listed below.

- ☒ Instrument air, at pressures as high as 150 psi, can be required pneumatically activated controls. Air pressure at this level can pose a *very dangerous situation*. Assure that the air source has been shutdown and that the line pressure has been bled before breaking any pneumatic connection.
1. Follow Steps 1 through 6 of the shutdown procedure (page 33) to take the unit off-line before attempting pneumatic service.
 2. After assuring the air source has been turned off, break and redo the pneumatic connections in question.
 3. Turn the air supply on and check that the component that has been reconnected is functioning properly.
 4. Follow the startup procedure on page 33 of this manual to return the unit to operation.

Heat Exchanger Coil and Gaskets - Inspection and Replacement

The "U-Bend" heat exchanger coil is the heart of Armstrong Unfired Steam Generators. It should be removed and inspected every two (2) years. There are two (2) gaskets, one (1) between the tube face of the coil and the flange welded to the tank, and one (1) gasket with a divider to fit between the head and the tubesheet.

- ☒ Clean steam and energy source steam, boiler water, or high temperature water present situations that can be *very dangerous* because of the high temperatures and pressures. To avoid possible injury or death, use common sense and follow all accepted and recommended procedures when performing installation, operation, and maintenance procedures.
 - ☒ The combination of electricity, steam, and water can pose a *very dangerous situation*. Turn off / disconnect all electric power before attempting any maintenance procedures.
1. Follow Steps 1 through 7 of the shutdown procedure (page 33) to take the unit off-line before attempting to remove and inspect the heat exchanger coil.
 2. Assure that the energy source, condensate / water return line, feed water inlet, and clean steam outlet have been shut off; that the pressure has been bled from both the clean steam and energy source systems; that the tank has been completely drained; and that the steam, water, all components, and surfaces have cooled.

3. Carefully break the joint between the heat exchanger coil head and the small line leading to the energy source pressure gauge.
4. Carefully break the connections between the heat exchanger coil head and the energy source inlet and outlet lines.

Note: *It may be necessary to break the lines at a second location, and for the lines to be rotated to allow clearance for the heat exchanger coil to be removed from the tank. If it is necessary, care should be taken to insure that in-line components are not damaged.*

5. Remove the bolts and nuts that secure the heat exchanger coil head to the tank, and remove all bolts from the unit.
6. Carefully separate the heat exchanger coil head from the mounting flange and remove the coil assembly from the tank.
- There may still be residual steam condensate (or boiler / high temperature water) in the coil that can run out during removal of the coil from the tank. If sufficient time has not been allowed for cooling, this residual condensate / water could present **a danger of injury**.
7. Examine the heat exchanger coil for scale buildup and signs of leakage. If no leakage is detected, carefully clean the excess scale from the coils and prepare the heat exchanger coil for installation. If leakage is detected between the coils and water in the tank, either repair the leaking coil(s) or replace the heat exchanger coil.
8. Remove the old gaskets and completely clean the mating surfaces. Install the two (2) new gaskets: one (1) between the tube face of the coil and the flange welded to the tank, and one (1) gasket with a divider to fit between the head and the tubesheet.
9. Carefully insert the heat exchanger coil into the tank. The coil should be installed so that the divider in the head lines up with the coil, and that the divider is parallel to the horizon.
10. After assuring that the heat exchanger unit is correctly aligned, clamp the flanges together and proceed with the torque procedure detailed below.

Note: *Bolts used to secure the heat exchanger unit in Armstrong Unfired Steam Generators are rated as either Grade A or Grade 5. Grade A bolts have no marking on the head. Grade 5 bolts are designated by three (3) slash marks on the head (///).*

- a. Lubricate the bolt threads and the nut faces with a suitable lubricant.
- b. Insert the bolts through the flanges, then start and finger tighten the nuts.
- c. Number all bolts so that torquing requirements can be followed.

Note: *Appendix A contains drawings depicting the typical flange configurations (number of bolts, location, tightening sequence, etc.) for Armstrong Unfired Steam Generators. Reference the applicable drawing for the unit being serviced.*

- d. Apply torque in twenty percent (20% [1/5]) steps of required final torque, loading all bolts at each step before proceeding to the next step. The following tables list ANSI approved target torques for both Grade A and Grade 5 bolts. The correct target torque can be determined by the nominal pipe size, number and grade of bolts used to secure the flange, and the size of the bolt used.

Be sure of the bolt grade used in the unit. Do not tighten a Grade 5 bolt to the torque specification of a Grade A bolt, or vice versa. When replacing bolts, be sure to use the same type of bolt and corresponding nuts. Grade 5 bolts can be used in all cases. Grade A bolts can only be used to replace Grade A bolts.

**Garlock Bolt Torque Values
Grade A Bolts**

.062" Ring Gaskets

ANSI - 150# Flanges

Nominal Pipe Size (IN)	Number of Bolts	Size of Bolts (IN)	Grade A Target Torque (FT - LBS)
2"	4	5/8"	96
2 1/2"	4	5/8"	96
3"	4	5/8"	96
3 1/2"	8	5/8"	96
4"	8	5/8"	96
5"	8	3/4"	160
6"	8	3/4"	160
8"	8	3/4"	160
10"	12	7/8"	184
12"	12	7/8"	184
14"	12	1"	250
16"	16	1"	250

**Garlock Bolt Torque Values
Grade 5 Bolts**

.062" Ring Gaskets

ANSI - 300# Flanges

Nominal Pipe Size (IN)	Number of Bolts	Size of Bolts (IN)	Grade 5 Target Torque (FT - LBS)
2"	8	5/8"	86
2 1/2"	8	3/4"	113
3"	8	3/4"	160
3 1/2"	8	3/4"	160
4"	8	3/4"	160
5"	8	3/4"	160
6"	12	3/4"	160
8"	12	7/8"	256
10"	16	1"	392
12"	16	1 1/8"	568
14"	20	1 1/8"	521
16"	20	1 1/4"	730

- e. Tighten bolts in the applicable sequential order (0 - 180°, 90° - 270°, 45° - 225°, 135° - 315°, etc.) at each step until final target torque is reached (see applicable diagram contained in Appendix A).

- f. Use rotational tightening until all bolts are stable at final torque level. Two (2) complete times around is usually required.
11. Reconnect the energy source inlet and clean steam outlet lines to the heat exchanger coil. If these lines were broken at an additional location to allow for removal of the coil, be sure to also tighten those connections. Follow recommendations contained in the manufacturer's documentation, local codes, or accepted contractor practices as to the use and / or type of joint compound or sealer at the connections.
12. Reconnect the small line leading to the energy source pressure gauge.
13. Follow the startup procedures (page 32) to put the unit back on-line. Carefully check all connections for any sign of leakage.

Level Controller - Inspection and Replacement

The level controller supplied on all Armstrong Unfired Steam Generators controls the level of the water within the unit, assuring that the unit will function safely and effectively. If the level controller must be removed for inspection, adjustment, or replacement, follow the steps detailed below.

- ☒ Clean steam and energy source steam, boiler water, or high temperature water present situations that can be *very dangerous* because of the high temperatures and pressures. To avoid possible injury or death, use common sense and follow all accepted and recommended procedures when performing installation, operation, and maintenance procedures.
 - ☒ The combination of electricity, steam, and water can pose a *very dangerous situation*. Turn off / disconnect all electric power before attempting any maintenance procedures.
1. Follow Steps 1 through 7 of the shutdown procedure (page 33) to take the unit off-line before attempting to remove and inspect the level controller.
 2. Assure that the energy source, condensate / water return line, feed water inlet, and clean steam outlet have been shut off; that the pressure has been bled from both the clean steam and energy source systems; that the tank has been completely drained; and that the steam, water, all components, and surfaces have cooled.
 3. If equipped, slowly open the tricocks located on the body of the level controller. Follow accepted practices in opening the tricocks. If not completely drained and bled, steam or boiling water may exit the tricocks.

Note: *Throughout the removal and installation process, care should be taken to assure that the water column gauge glass is not damaged or broken.*

4. Disconnect the wires leading from the level controller to the junction box at the slide connector.
5. Carefully break the joint at the top of the level controller and the top of the tank.
6. With the level controller secured or held in place by an assistant, carefully break the joint at the bottom of the level controller.

Note: *It may be necessary to break the lines at a second location to allow clearance for the level controller to be removed from the tank. If it is necessary, care should be taken to insure that in-line components are not damaged.*

7. After breaking both the top and bottom joints, continue loosening the connections until the level controller can be removed.
8. Examine the level controller for damage or incorrect positioning of the floats. For the exact procedure for examination or repositioning the floats, refer to the manufacturer's information included with the unit.

If the unit is fitted with a Armstrong Level Controller, refer to appendix B of this manual for examination and float repositioning procedures.

9. To install the level controller, align the controller with the feed lines and start the fittings. Follow recommendations contained in the manufacturer's documentation, local codes, or accepted contractor practices as to the use and / or type of joint compound or sealer at the connections.
10. After assuring that the level controller is correctly aligned, tighten the fittings.
11. Follow the startup procedures (page 32) to put the unit back on-line. Carefully check all connections for any sign of leakage.

Inlet, Outlet, and Condensate / Water Return Line and Manual Shutoff Valves - Replacement

If any of the inlet, outlet, return lines, or shutoff valves are damaged and must be replaced, follow the steps outlined below.

The combination of electricity, steam, and water can pose a ***very dangerous situation***. Turn off / disconnect all electric power before attempting any maintenance procedures.

1. Follow Steps 1 through 7 of the shutdown procedure (page 33) to take the unit off-line before attempting to replace damaged lines or shutoff valves.

- ☒ While it might seem feasible to replace inlet, outlet, condensate / water return lines, and shutoff valves without shutting down the entire unit, ***it is not advised***. Unless the unit is completely shutdown, and the clean steam and energy source are isolated from the system, failure of a manual shutoff valve during the replacement process could result in serious injury.
- 2. Assure that the energy source, condensate / water return line, feed water inlet, and clean steam outlet have been shut off; that the pressure has been bled from both the clean steam and energy source systems; that the tank has been completely drained; and that all components and surfaces have cooled.
- 3. Carefully break the joint between the unit and the line or valve to be replaced.
- 4. Remove the section of line or valve to be replaced.
- 5. Replace the damaged section of line or valve.
- 6. Reconnect the line or valve to the unit. Follow recommendations contained in the manufacturer's documentation, local codes, or accepted contractor practices as to the use and / or type of joint compound or sealer at the connections.
- 7. Follow the startup procedures (page 32) to put the unit back on-line. Carefully check all connections for any sign of leakage.

Pressure Gauge (Energy Source) - Replacement

If the pressure gauge for the energy source does not function correctly and must be replaced, follow the procedures outlined below.

- ☒ The combination of electricity, steam, and water can pose a ***very dangerous situation***. Turn off / disconnect all electric power before attempting any maintenance procedure.
- 1. Follow Steps 1 through 7 of the shutdown procedure (page 33) to take the unit off-line before attempting to replace the energy source pressure gauge.
- 2. Carefully disconnect the small line connecting the pressure gauge with the heat exchanger coil head from both the head and gauge.
- 3. Remove the gauge from its mounting.
- 4. Mount the new gauge.
- 5. Reconnect the small line to both the heat exchanger coil head and the gauge. Follow recommendations contained in the manufacturer's documentation, local codes, or accepted contractor practices as to the use and / or type of joint compound or sealer at the connections.

6. Follow the startup procedures (page 32) to put the unit back on-line. Carefully check all connections for any sign of leakage.

Pressure Gauge (Clean Steam) - Replacement

If the pressure gauge for the water tank is not functioning correctly and must be replaced, follow the procedures outlined below.

- ☒ The combination of electricity, steam, and water can pose a *very dangerous situation*. Turn off / disconnect all electric power before attempting any maintenance procedures.
1. Follow Steps 1 through 7 of the shutdown procedure (page 33) to take the unit off-line before attempting to replace the clean steam pressure gauge.
 2. Carefully disconnect the small line connecting the pressure gauge with the tank. This line should only be disconnected at the gauge.
 3. Remove the gauge from its mounting.
 4. Mount the new gauge.
 5. Reconnect the small line to the gauge. Follow recommendations contained in the manufacturer's documentation, local codes, or accepted contractor practices as to the use and / or type of joint compound or sealer at the connections.
 6. Follow the startup procedures (page 32) to put the unit back on-line. Carefully check all connections for any sign of leakage.

Pressure Relief Valve (Tank) - Replacement

If the water pressure relief valve mounted on the tank is not functioning correctly and must be replaced, follow the procedures outlined below.

- ☒ The combination of electricity, steam, and water can pose a *very dangerous situation*. Turn off / disconnect all electric power before attempting any maintenance procedure.
1. Follow Steps 1 through 7 of the shutdown procedure (page 33) to take the unit off-line before attempting to replace the water pressure relief valve.
 2. After assuring that the pressure has been relieved from the tank, disconnect the vent line leading from the pressure relief valve to atmosphere (usually through the roof), and via a drip elbow, to drain.
 3. Carefully unscrew the pressure relief valve from the port in the tank.

4. Install the new valve by screwing it into the pressure relief valve port in the tank. Follow recommendations contained in the manufacturer's documentation, local codes, or accepted contractor practices as to the use of joint compound or sealer at the connections.
5. Reconnect the vent line leading from the pressure relief valve to atmosphere and, via drip elbow, to drain.
6. Follow the startup procedures (page 32) to put the unit back on-line. carefully check all connections for any sign of leakage.

Solenoid Safety System - Inspection and Replacement

The solenoid safety system acts as a fail-safe for Armstrong Unfired Steam Generators. The system requires power to operate, therefore in the case of a power failure, the system will totally shutdown the unit. If it is mandatory that the unit remain in operation during power failures, it should be wired into the buildings emergency power system. **Before this is done, it is the duty of the installer / operator to check local codes and requirements to assure that this is an acceptable configuration.**

When power is supplied to the solenoid safety system, the system allows the electrically operated controls to feed water to the system and generate clean steam. The system should be checked semi-annually. (See manufacturer's documentation for the solenoid safety system provided with the unit for specific inspection intervals and test routine). If the system is found to be malfunctioning and must be replaced, follow the procedure outlined below.

Note: The exact location and configuration of the solenoid safety system can vary between units. See the C.A.D. drawing supplied with the Submittal sheet and design specifications supplied with the unit for the exact placement and configuration.

- ☒ The combination of electricity, steam, and water can pose a ***very dangerous situation***. Turn off / disconnect all electric power before attempting any maintenance procedure.
1. Follow Steps 1 through 7 of the shutdown procedure (page 33) to take the unit off-line before attempting to replace the solenoid safety system.
 2. Carefully disconnect the small line connecting the solenoid safety system to the energy source control valve. This line should only be disconnected at the safety system.

3. Carefully disconnect the small line connecting the solenoid safety system to the tank or clean steam outlet line. This line should only be disconnected at the safety system.
4. If the system is electrically activated, turn off the power and disconnect the electric leads from the safety system.
5. If the system is pneumatically activated, turn off the instrument air source and disconnect the pneumatic lines from the solenoid safety system.
6. Remove the solenoid safety system from its mounting.
7. Mount the new safety system.
8. Reconnect the small line from the tank or clean steam outlet line to the safety system. Follow recommendations contained in the manufacturer's documentation, local codes, or accepted contractor practices as to the use and / or type of joint compound or sealer at the connections.

Note: *For steps 8 & 9, the use and type of joint sealer should be determined from local codes or the specifications of the installing contractor.*

9. Reconnect the small line from the energy source control valve to the safety system.
10. If any were disconnected, reconnect all electric and pneumatic lines and restore power and instrument air to the system .
11. Reference the manufacturer's documentation for the safety system that was supplied with your unit for additional installation / setup instructions.
12. Follow the startup procedures (page 32) to put the unit back on-line. Carefully check all connections for any sign of leakage.

Strainers - Inspection and Replacement

The strainers are installed upstream of the energy source shutoff valve for both the coil and the main traps. These strainers must be blown down periodically (approximately every three (3) to six (6) months) to prevent the build up of any sediment.

☒ The combination of electricity, steam, and water can pose a ***very dangerous situation***. Turn off / disconnect all electric power before attempting any maintenance procedures.

1. Follow Steps 1 through 7 of the shutdown procedure (page 33) to take the unit off-line before attempting to replace the energy source pressure gauge.

2. The exact location of the strainers can differ between units. Reference the C.A.D. drawing supplied with the Submittal sheet for the unit to identify the location of the strainers on the unit.
3. Carefully break the line connections on the inlet side of both strainers.
4. Carefully break the line connection on the outlet side of the strainers.
5. Remove and examine the strainers.
6. Remove any sediment that is present in the strainers. If they can not be satisfactorily cleaned, replace with new strainers.
7. Place the strainers back in-line in the system.
8. Reconnect the inlet and outlet lines to each strainer. Follow recommendations contained in the manufacturer's documentation, local codes, or accepted contractor practices as to the use and / or type of joint compound or sealer at the connections.
9. Follow the startup procedures (page 32) to put the unit back on-line. Carefully check all connections for any sign of leakage.

Pressure Control Valve - Inspection and Replacement

The pressure control valve is installed upstream of the heat exchanger coil and ***must be interlocked*** with the high pressure cutoff solenoid. The manufacturer documentation included with the unit gives specifics for operation and maintenance of the control valve. The Submittal sheet and C.A.D. drawing included with the unit will give the exact location, as well as interlocks with other components. This information should be reviewed before removal / replacement of the temperature control valve.

- ☒ Steam, boiler water, or high temperature water present situations that can be ***very dangerous*** because of the high temperatures and pressures. Use common sense and follow all accepted and recommended procedures when performing installation, operation, and maintenance procedures to avoid possible injury or death.
 - ☒ The combination of electricity, steam, and water can pose a ***very dangerous situation***. Turn off / disconnect all electric power before attempting any maintenance procedures.
1. Follow Steps 1 through 7 of the shutdown procedure (page 33) to take the unit off-line before attempting to remove and inspect the temperature control valve.

2. Assure that the energy source, condensate / water return line, feed water inlet, and clean steam outlet have been shut off; that the pressure has been bled from both the steam and energy source systems; that the tank has been completely drained; and that all components and surfaces have cooled.
3. If the pressure control valve is electrically activated, turn off the power and disconnect the leads to the valve.
4. If the pressure control valve is pneumatically activated, turn off the instrument air source, bleed the pressure from the line, and disconnect the lines to the valve.
5. Carefully break the joints between the pressure control valve and feed water valve, solenoid safety unit, and the auxiliary trap line.
6. Carefully break the connections between the energy source inlet line and the heat exchanger coil.

Note: It may be necessary to break the lines at a second location, and for the lines to be rotated to allow clearance for the temperature control valve to be removed from the system. If it is necessary, care should be taken to insure that in-line components are not damaged.

7. Remove the pressure control valve from the system.
8. Follow the supplied manufacturer instructions for inspecting the valve. If found to be malfunctioning, replace the valve.
9. Carefully replace the pressure control valve into the system by reattaching it to the energy source inlet line and the heat exchanger coil outlet line. Follow recommendations contained in the manufacturer's documentation, local codes, or accepted contractor practices as to the use and / or type of joint compound or sealer at the connections.
10. Align the valve as it was situated before removal and tighten the connections. If lines were broken at an additional location to allow for removal of the valve, be sure to also tighten those connections.
11. Reconnect the pressure control valve to the feed water valve, solenoid safety unit, and the auxiliary trap line.
12. Follow the startup procedures (page 32) to put the unit back on-line. Carefully check all connections for any sign of leakage.

Traps (Main and Auxiliary) - Replacement (Steam Systems Only)

The main and auxiliary traps are installed upstream of the condensate shutoff valve on units that use steam as the energy source. The traps are designed to maintain the flow of condensate with the rise and fall of the float as changes in condensate level occur within the body of the trap. If the traps are not functioning properly and must be replaced, follow the procedures outlined below.

- ☒ The combination of electricity, steam, and water can pose a *very dangerous situation*. Turn off / disconnect all electric power before attempting any maintenance procedures.
1. Follow Steps 1 through 7 of the shutdown procedure (page 33) to take the unit off-line before attempting to replace the main or auxiliary traps.
 2. The exact location of the traps can differ between units. Reference the Submittal sheet and C.A.D. drawing supplied with the unit to identify the location of the traps on the unit.
 3. Carefully break the joint on the inlet side of both traps.
 4. Carefully break the joint on the outlet side of the traps.
 5. Remove and examine the traps.
 6. If the traps are not functioning properly, replace them with new traps.
 7. Place the traps back in-line in the system.
 8. Reconnect the inlet and outlet lines to each trap. Follow recommendations contained in the manufacturer's documentation, local codes, or accepted contractor practices as to the use and / or type of joint compound or sealer at the connections.
 9. Follow the startup procedures (page 32) to put the unit back on-line. Carefully check all connections for any sign of leakage

Appendix A

Bolt Torque Procedure

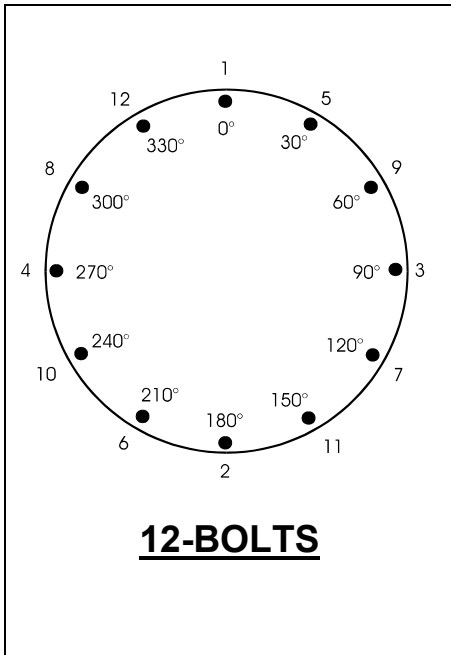
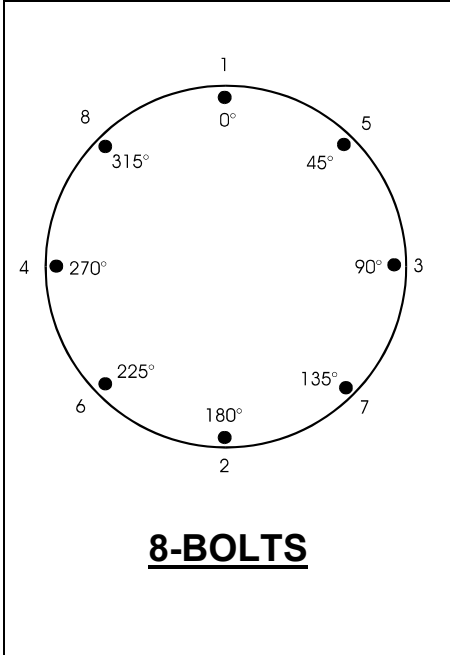

Appendix A (cont'd)

Bolt Torque Procedure

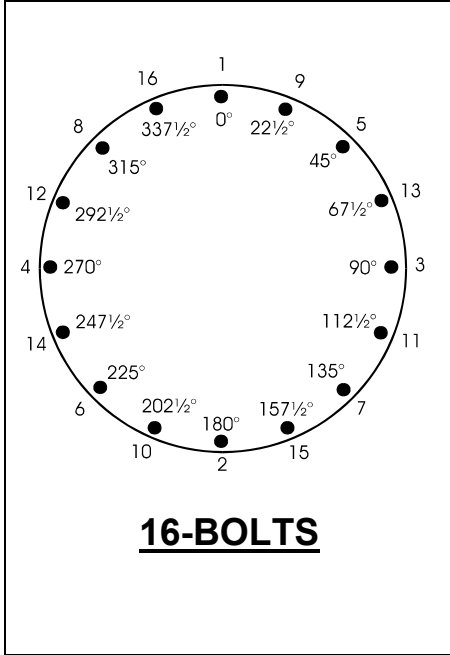

Sequential Order

- 1 - 2
- 3 - 4
- 5 - 6
- 7 - 8
- 9 - 10
- 11 - 12
- 13 - 14
- 15 - 16

Rotational Order

- 1
- 9
- 5
- 13
- 3
- 11
- 7
- 15
- 2
- 10
- 6
- 14
- 4
- 12
- 8
- 16

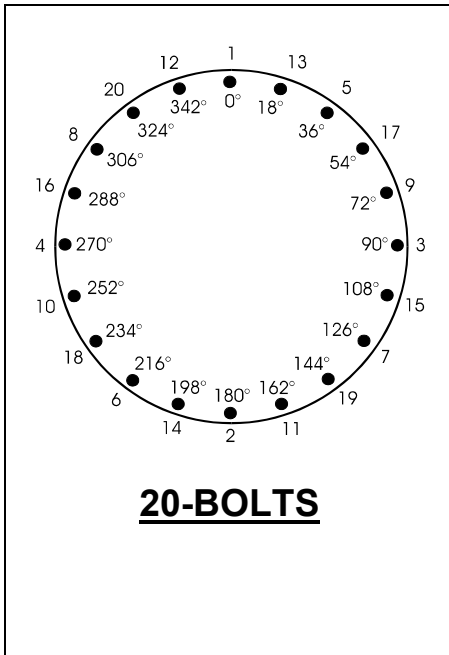

Sequential Order

- 1 - 2
- 3 - 4
- 5 - 6
- 7 - 8
- 9 - 10
- 11 - 12
- 13 - 14
- 15 - 16
- 17 - 18
- 19 - 20

Rotational Order

- 1
- 13
- 5
- 17
- 9
- 3
- 15
- 7
- 19
- 11
- 2
- 14
- 6
- 18
- 10
- 4
- 16
- 8
- 20
- 12

Appendix B

Armstrong Stainless Steel Level Controller Adjustment and Maintenance

The Stainless Steel Level Controller, supplied with your Unfired Steam Generator, has been preset at the factory to control the feed water level within the unit according to design specifications. However, it is possible for the preset float position to become incorrect due to rough handling during shipping. If the level controller is not functioning properly after installation (i.e.: incorrect feed water level within the tank), follow the procedures detailed below to verify the float positions and to reset the floats if necessary.

- ☒ Clean steam and energy source steam, boiler water, or high temperature water present situations that can be ***very dangerous*** because of the high temperatures and pressures. To avoid possible injury or death, use common sense and follow all accepted and recommended procedures when performing installation, operation, and maintenance procedures.
- ☒ The combination of electricity, steam, and water can pose a ***very dangerous situation***. Turn off / disconnect all electric power before attempting any maintenance procedures.

Removal and Dismantling Procedures

1. Follow Steps 1 through 8 of the level controller inspection and replacement procedures (page 49) to take the unit off-line and to remove the level controller from the system.

Note: Care should be taken throughout all procedures to assure that the sight (level) glass is not damaged.

2. After removing the level controller, it should be placed on a firm, level surface, free of dirt or debris, on which dismantling and reassembly procedures can be carried out.
3. Remove the four (4) bolts and nuts securing the top flange to the body of the unit (see Figure B-1).
4. Carefully remove the top flange and float assembly from the body of the level controller by breaking the gasket seal and withdrawing it from the body of the level controller.

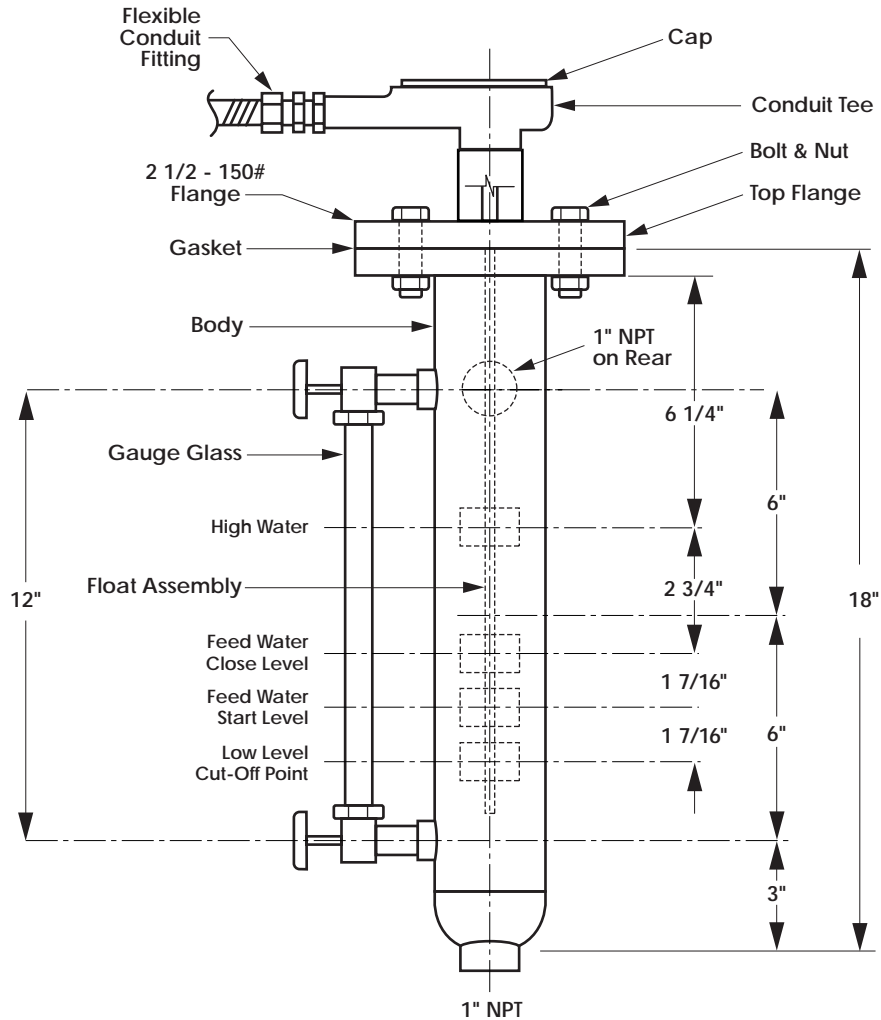

Figure B-1: Armstrong Stainless Steel Level Controller Schematic

Inspection and Adjustment

After removing the top flange and float assembly from the body of the level controller, examine the floats for signs of physical damage. If no visible damage is detected, check to assure that the floats are still in the factory preset position. Figure B-2 illustrates the float assembly and lists the normal float positions.

Note: *If the float settings for the particular unit vary from the normal float positions contained in Figure B-2, the proper settings for the unit will be listed in the design specifications and C.A.D. drawing supplied with the unit.*

The upper and lower travel limit of each float is controlled by lock rings secured by set screws. If the floats are found to be out of adjustment, complete the following procedures to reset the floats.

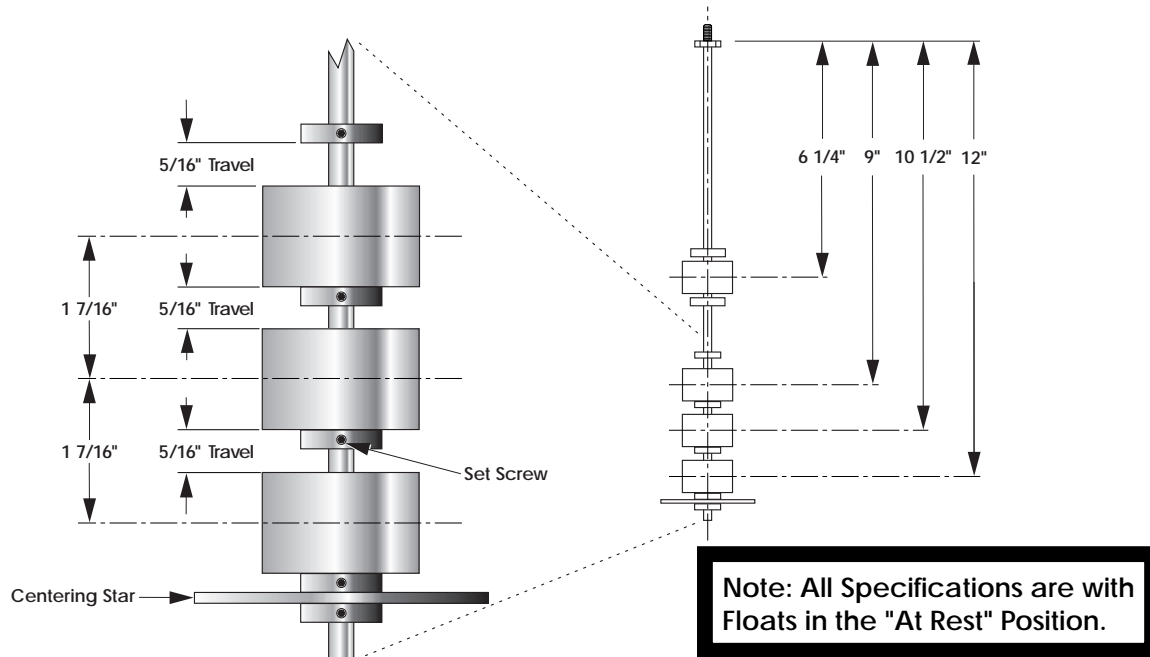

Figure B-2: Detail of Typical Float Settings

1. The "At Rest" position for the bottom float (float resting on bottom lock ring - lower travel limit) should be set first. With the top flange and float assembly held vertically, the distance from the bottom of the threads of the float shaft (bottom of the flange) to the center of the float should be 12". To adjust this distance, loosen the set screw (Allen screw) securing the lock ring and move to the desired position. After the position is correct, tighten the set screw.
2. The "At Rest" position for the middle float should be set so that the distance between the centers of the bottom and middle floats is 1-7/16". Again, loosen the set screw, reposition the lock ring, and tighten the set screw if the position must be adjusted.

3. The "At Rest" position for the top float should be set so that the distance between the centers of the middle and top floats is 1-7/16". Again, loosen the set screw, reposition the lock ring, and tighten the set screw if the position must be adjusted.
4. The position of the top locking ring should be set to give 5/16" travel for the top float.

Test for Reed Switches

To test the operation of the reed switches in the level controller float assembly, connect an ohm meter to the black wire and in succession the red, yellow, and blue wires. With the bottom float in the "At Rest" position (float resting on the locking ring) and the meter connected to the black and red wires, the meter should read zero (0) ohms (closed circuit). With the float up, so its top touches the locking ring above, the ohm meter should read infinite ohms (open circuit)

Connect the ohm meter to the black and yellow wires and repeat the same test for the middle float.

Connect the ohm meter to the black and blue wires and repeat the same test for the top float.

If any of the floats do not show closed circuit in the "At Rest" position and open circuit in the raised position (and the float settings have been adjusted), one or more of the reed switches in the float assembly is defective and the float assembly should be replaced.

Caution: The reed switches in the float assembly are suitable for no more than 100 VA at 120 volts. Do not connect any load other than the ohm meter, or the relays supplied with the level controller to these switches.

Reassembly

1. Remove all traces of the original gasket between the top flanges and install a new gasket. Follow local codes, or accepted contractor practices, as to the use of joint compound or sealer on the gasket and mating surfaces.
2. After all floats have been repositioned, and the new positions verified one last time, the float assembly is ready to be inserted into the body of the level controller.
3. Once the float assembly is repositioned in the body of the level controller, and the correct positioning of the gasket is confirmed, install and tighten the four (4) bolts and nuts that secure the flanges. The bolts should be torqued to 96 ft/lb, using the rotational technique detailed in Appendix A.

4. Reinstall the level controller in the system by following Steps 9 through 11 of the level controller inspection and replacement procedures on page 50 of this manual.
5. Return the unit to operation by following the startup procedures on page 32 of this manual.