

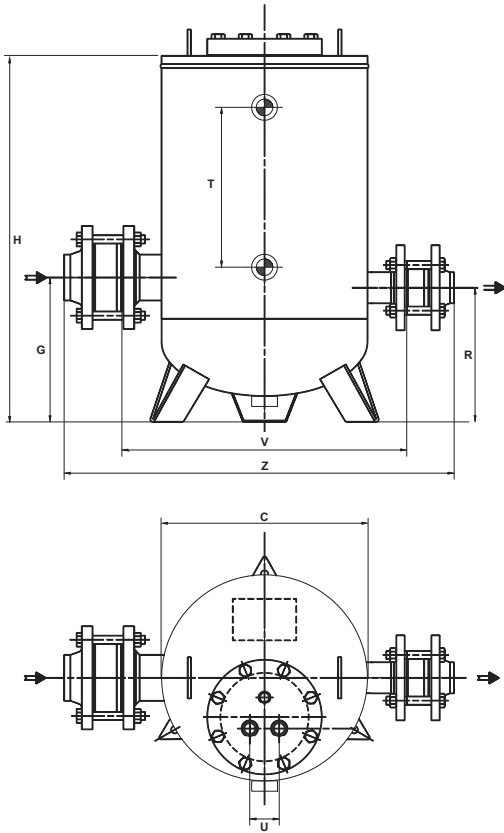

# EPT-400 Series Pumping Trap

Carbon Steel, In-Line Connections

For capacities up to 7 310 kg/h (steam motive)... Discharge per cycle 29 liters



Condensate Recovery Equipment

The Armstrong EPT-400 Series Vertical Pump Trap is the low maintenance, non-electric solution to move condensate or other liquids from low points, low pressures or vacuum spaces to an area of higher elevation or pressure. Condensate can be returned at temperatures well above the 99°C limit of conventional electric condensate pumps without the headaches of leaking seals or cavitation problems.

## Features

- Non-electric – Uses inexpensive steam, air or gas to operate the pump trap
- Explosion proof – Intrinsically safe
- AD-Merkblätter carbon steel or stainless steel body vessel
- Low maintenance – No leaking seals, impeller or motor problems
- All stainless steel internals with durable Inconel X-750 springs
- Externally removable/replaceable seats – Valve and seats can be replaced or cleaned without removing pump cap from body

**Table CRE-224-1. EPT-400 Pumping Trap Physical Data**

Model Number	EPT-404	EPT-406	EPT-408	EPT-412
	mm	mm	mm	mm
"C" (diameter)	400	400	400	400
"G"	260	260	260	260
"H"	710	710	710	710
"R"	240	240	240	240
"T"	305	305	305	305
"U"	57	57	57	57
"V"	552	552	552	552
"Z"	680	710	730	750
Cap Removal	400	400	400	400
Weight (kg)	67	71	75	88
Number of Cap Bolts	8	8	8	8

Maximum Allowable Pressure (Vessel Design) 10 barg @ 250°C.  
Maximum Operating Pressure 9 barg.  
All models are CE Marked according to the PED (97/23/EC).

*All dimensions and weights are approximate. Use certified print for exact dimensions. Design and materials are subject to change without notice.*

Armstrong International SA • Parc Industriel des Hauts-Sarts (2<sup>e</sup> Avenue) • 4040 Herstal • Belgium

Tel.: +32 (0)4 240 90 90 • Fax: +32 (0)4 240 40 33

www.armstronginternational.eu • info@armstronginternational.eu

# EPT-400 Series Pumping Trap

Carbon Steel, In-Line Connections

For capacities up to 7 310 kg/h (steam motive)... Discharge per cycle 29 liters



	EPT-404	EPT-406	EPT-408	EPT-412
Inlet	DN 25	DN 40	DN 50	DN 80
Inlet Check Valve	DN 25	DN 40	DN 50	DN 80
Outlet	DN 25	DN 40	DN 50	DN 50
Outlet Check Valve	DN 25	DN 40	DN 50	DN 50
Motive Valve	1/2" BSPT			
Vent Valve	1" BSPT			
Body Drain	1/2" NPT			
Gauge Glass	1/2" BSPT			
Cycle Counter	1/2" BSPT			

Body and Cap	Fabricated Steel P265GH/P275H AD-Merkblätter
Cap Gasket	Compressed Non-Asbestos
Bolts	SA - 193 gr B7
Inlet Valve Assembly	Stainless Steel
Vent Valve Assembly	Stainless Steel
Valve Assembly Washers	Zinc-Plated Steel
Mechanism Assembly	Cast Stainless Steel
Plug	Steel
Springs	Inconel X-750

Motive Pressure	Total Lift or Back Pressure	EPT-404		EPT-406		EPT-408		EPT-412	
		DN 25 x DN 25		DN 40 x DN 40		DN 50 x DN 50		DN 80 x DN 50	
		Steam	Air	Steam	Air	Steam	Air	Steam	Air
bar	bar	kg/h	kg/h	kg/h	kg/h	kg/h	kg/h	kg/h	kg/h
1,0	0,35	945	1 120	1 545	1 670	2 245	2 420	3 740	4 045
		1 250	1 320	2 290	2 430	3 295	3 495	5 490	5 815
		1 545	1 610	2 440	2 454	3 540	3 680	5 840	6 060
		1 695	1 750	2 595	2 645	3 590	3 695	5 990	6 160
		1 750	On request	2 695	On request	3 640	On request	6 040	On request
		1 800	On request	2 745	On request	3 695	On request	6 090	On request
1,7	1,0	1 100	1 260	1 750	2 010	2 695	3 090	3 590	4 130
		1 300	1 400	2 045	2 210	3 145	3 395	5 190	5 615
		1 400	1 475	2 195	2 370	3 245	3 445	5 390	5 715
		1 545	On request	2 400	On request	3 345	On request	5 490	On request
		1 595	On request	2 440	On request	3 395	On request	5 590	On request
2,5	1,5	1 000	1 170	1 445	1 710	2 095	2 470	3 445	4 070
		1 200	1 335	2 000	2 245	2 895	3 195	4 840	5 410
		1 300	1 400	2 145	2 270	2 990	3 245	4 990	5 440
		1 400	On request	2 345	On request	3 050	On request	5 090	On request
		1 450	On request	2 980	On request	3 195	On request	5 190	On request
3,5	3,0	945	1 170	1 595	2 025	2 170	2 675	2 895	3 555
		1 100	1 300	1 800	2 125	2 545	3 000	3 445	4 070
		1 200	1 335	2 000	2 235	2 845	3 185	3 790	4 240
		1 250	On request	2 095	On request	2 990	On request	4 045	On request
		1 350	On request	2 245	On request	3 095	On request	4 240	On request
4,5	4,0	900	1 200	1 595	2 145	1 900	2 520	2 500	3 315
		1 000	1 220	1 750	2 320	2 045	2 580	2 695	3 445
		1 360	On request	1 850	On request	2 245	On request	2 995	On request
		1 200	On request	1 900	On request	2 395	On request	3 195	On request

Notes: Above capacities are the results of actual steam testing using a minimum 93°C condensate. Published capacities are based on the use of external check valves supplied by Armstrong. Fill head measured from drain point to top of pump cap. Discharge per cycle: 29 liters.

Model	Filling Head (mm)				
	0	150	300	600	900
EPT-404	0,70	0,85	1,00	1,30	1,40
EPT-406	0,70	0,85	1,00	1,20	1,35
EPT-408	0,70	0,70	1,00	1,20	1,35
EPT-412	0,70	0,85	1,00	1,08	1,20

Note: Filling head is measured from drain of receiver to top of pump's cap.

## Options

- Stainless 316L Body and Cap
- Gauge Glass Assembly with Guards (Brass or Cadmium Plated Carbon Steel)
- Digital Cycle Counter (Open or Closed Systems; with or without Auxiliary contacts)
- Insulation Jacket

This pump might be suitable for special applications. Please consult factory

All dimensions and weights are approximate. Use certified print for exact dimensions. Design and materials are subject to change without notice.