



EPT-104 Series Low Profile Pumping Trap

Cast Iron, In-Line or Same Side Connections

For capacities up to 900 kg/h (steam motive)... Discharge per cycle 7 liters

The patented Armstrong EPT-104 Mini Pump Trap is one of the smallest non-electric solution that can move condensate or other liquids from lower to higher points and from lower to higher pressures. Condensate can be returned at temperatures well above the 99°C limit of conventional electric centrifugal pumps without the headaches of leaking seals or cavitation problems. The EPT-104 Mini Pump Trap is the small solution for a big problem.

Features

- Non-electric – Operates using inexpensive steam, air or inert gas
- Low maintenance – No leaking seals, impeller or motor problems, reducing maintenance and downtime
- Small and compact – Low profile body fits in tight space requirements while allowing minimal fill head
- Reduced installation cost – Single trade required for installation and maintenance
- Explosion proof – Standard unit intrinsically safe
- All stainless steel internals – Corrosion resistant with long service life
- Long-lasting Inconel X-750 springs

Condensate Recovery Equipment

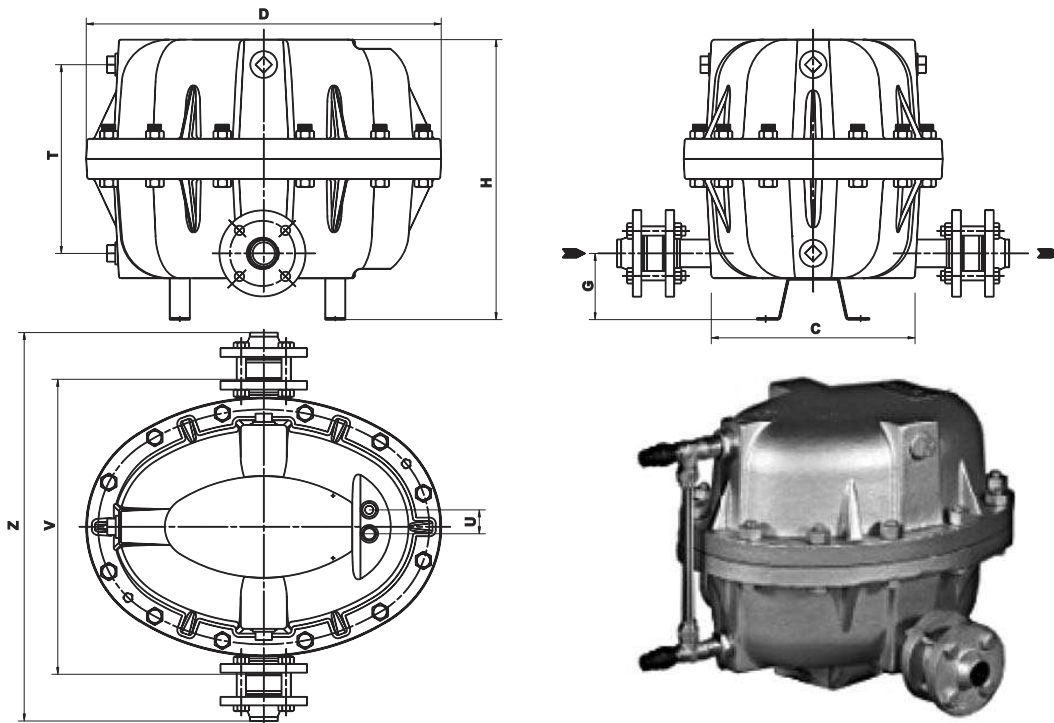

Table CRE-218-1. EPT-104 Pumping Trap Physical Data

Model Number	EPT-104
	mm
"C"	273
"D"	470
"G"	125
"H"	400
"T"	256
"U"	32
"V"	435
"Z"	570
Cap Removal	150
Weight (kg)	66
Number of Cap Bolts	12
Maximum Operating Pressure	6 bar
Maximum Allowable Pressure (vessel design)	10 bar @ 232°C

This model is CE Marked according to the PED (97/23/EC).

Table CRE-218-2. EPT-104 Pumping Trap Materials

Body and Cap	Cast Iron ASTM A48 cl.30
Motive / Vent Valves	Stainless Steel
Mechanism Assembly	Cast Stainless Steel
Spring	Inconel X-750
Bolts	SA 449
Nuts	ASTM A194 Gr. 2H
Plug	Cast Iron
Gasket	Compresses Non-Asbestos

Table CRE-218-3. EPT-104 Pumping Trap Connection Sizes

Inlet	DN 25
Inlet Check Valve	DN 25
Outlet	DN 25
Outlet Check Valve	DN 25
Motive Valve	1/2" NPT
Vent Valve	1/2" NPT
Gauge Glass	1" NPT
Cycle Counter	1" NPT

All dimensions and weights are approximate. Use certified print for exact dimensions. Design and materials are subject to change without notice.

Armstrong International SA • Parc Industriel des Hauts-Sarts (2^e Avenue) • 4040 Herstal • Belgium

Tel.: +32 (0)4 240 90 90 • Fax: +32 (0)4 240 40 33

www.armstronginternational.eu • info@armstronginternational.eu

EPT-104 Series Low Profile Pumping Trap

Cast Iron, In-Line or Same Side Connections

For capacities up to 900 kg/h (steam motive)... Discharge per cycle 7 liters

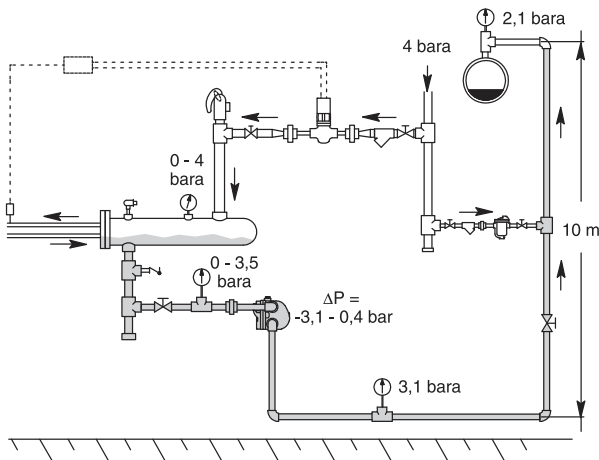

Big Problem = Maintenance Headache!

1. Space constraints – Heat exchanger equipment being low to the floor.
2. No condensate drainage – Back pressure exceeds system pressure.
3. Heat exchanger equipment floods, causing equipment damage from:
 - Water hammer – Steam and condensate occupying the same space
 - Corrosion – Non-condensable gases are reabsorbed into the condensate, forming carbonic acid
4. Production loss – Due to inaccurate temperature control.

Filling Head (mm)	0	150	300	600 or greater
EPT-104	0,7	1,0	1,2	Consult factory

Note: Filling head is measured from drain of receiver to top of pump's cap.

Options

- Gauge Glass Assembly with Guards (Brass or Cadmium Plated Carbon Steel)
- Digital Cycle Counter (Open or Closed Systems; with or without Auxiliary contacts)
- Insulation Jacket

This pump might be suitable for special applications. Please consult factory

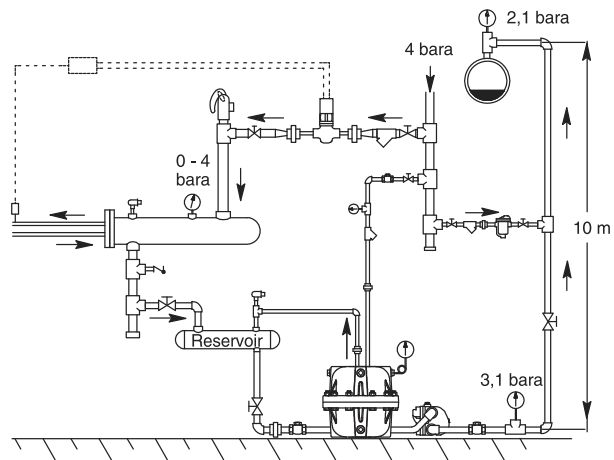

Small Solution = Long, trouble-free service life for heat exchanger equipment due to condensate and non-condensable gas evacuation.

1. Small and compact – EPT-104 Mini Pump Trap fits in tight spaces.
2. Condensate drainage – Motive pressure to EPT-104 Mini Pump Trap provides enough pressure to lift condensate to return lines.
3. Heat exchanger is free and clear of condensate due to proper drainage, provided by the EPT-104 Mini Pump Trap.
4. Accurate temperature control providing less product loss.

Motive Pressure	Total Lift or Back Pressure	Steam Motive	Air Motive
bar	bar	kg/h	kg/h
1,0	0,35	510	950
1,7		590	1 000
3,5		705	1 030
5,0	1,0	750	1 045
1,7		295	860
3,5		320	930
5,0	1,5	340	950
2,5		180	815
3,5		205	880
5,0	3,0	230	930
3,5		115	735
5,0		135	825

Notes: Above capacities are the results of actual steam testing using a minimum 93°C condensate. Published capacities are based on the use of external check valves supplied by Armstrong. Fill head measured from drain point to top of pump case. Discharge per cycle 7 liters.

Condensate Recovery Equipment