



Digital

BrainWave™ Model DMV2

Concealed electronic mixing valve with surface mount control panel for **individual shower** flow and +/-2°F (+/-1°C) temperature control.

Operational Specifications

- Programmable timed flow
- No touch on/off flow control
- No touch temperature adjustment
- Programmable minimum/maximum temperature access limits
- Programmable service flush
- Programmable thermal disinfection mode
- Data logging capabilities



BrainWave™ Model DMV2-Individual Shower

Concealed electronic mixing valve for showers offering programmable maximum, minimum and default temperatures, service flush and thermal disinfection with data logging capabilities.

Supplied complete with programmable software via PDA, power supply, check valves and strainers. Wall mounted control panel offering infra-red no-touch controls for flow and temperature adjustment and programmable timed flow control.



For a fully detailed certified drawing, refer to CDLW #1148.

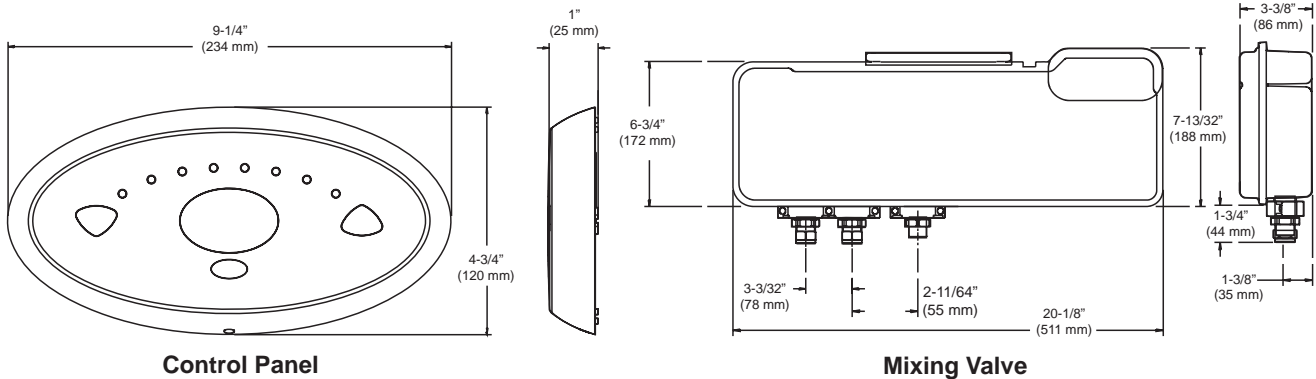

BrainWave™ Digital Mixing Valves

Model	Pressure Drop (psi)										Min. Flow	Max.* Flow	C _v
	5	10	15	20	25	30	35	40	45	50			
DMV1	3	4	5	6	6	7	7	8	9	9	1	7*	1.2
DMV2	6	8	10	11	12	14	15	16	17	18	1.6	16*	2.5
DMV3													
DMV23													

All dimensions and weights are approximate. Use certified print for exact dimensions. Design and materials are subject to change without notice.

Digital

BrainWave™ Model DMV2-Individual Shower

Technical Specifications

Connections

- Inlet and outlet connections: 1/2" NPT

Materials

- Control panel cover: Chrome ABS or optional stainless steel
- Mixing unit enclosure: PC/ABS
- Integral components: DZR brass stainless steel and engineering plastic

Temperatures

- Factory pre-set:
Min 86°F (30°C), Max 106°F (41°C),
Default 100°F (38°C)
- Programmable range:
Min 86°F - 117°F (30°C - 47°C),
Max 91°F - 122°F (33°C - 50°C),
Default 86°F - 122°F (30°C - 50°C)
Full cold can also be selected
- Minimum blend temperature differential from hot supply:
5°F (2°C)
- Optimum thermostatic control range:
86°F - 122°F (30°C - 50°C)
- Inlet Cold water range (recommended):
34°F - 68°F (1°C - 20°C)
- Inlet Hot water range (recommended):
122°F - 149°F (50°C - 65°C)
185°F (85°C) during disinfection

Performance

- Thermal shutdown upon inlet supply failure
- +/- 2°F (+/- 1°C) delivery temperature stability
- Minimum flow rate at recommended supply conditions:
1 GPM (4 LPM) at <72 psi maintained pressure
1.6 GPM (6 LPM) at >72 psi maintained pressure.

Thermal Disinfection

- Factory Settings
Min. Temperature: 140°F (60°C)
Min. Time: 5 minutes
- Programmable Range
Min. Temperature: 140 - 185°F (60 - 85°C)
Min. Time: 0 - 50 minutes
Reduced water flow during disinfection can be selected.

Environment

- Ambient temperature: 34°F - 104°F (1°C - 40°C)
- Maximum relative humidity: 95% non-condensing

Pressures

- Maximum static pressure: 145 psi (10 bar)
- Maximum inlet supply pressure differential:
3:1 (equal inlet pressure recommended)

IP Rating

- Control panel: IP45
- Overall valve enclosure: IP24
- Electronics compartment: IP45
- PSU: IP45

Electrical

- Supply Voltage: 120V 50-60Hz
- Maximum load: 20W at 12V DC
- Control panel cable length: 10 ft. (3m) supplied
- Maximum distance 20 ft. (6m)

Times - Factory settings

- Flow time: 15 seconds
- Service flush cycle: 2 minutes
- Service flush waiting period: 12 hours

Programmable range

- Flow time: 5 seconds - 60 minutes
- Service flush cycle: 1 minute - 59 minutes
- Service flush waiting period: 1 hour - 983 hours

Operation

- Temperature selector: Full no-touch temperature control
- Flow control: No-touch on/off - timed flow

Approvals

- ASSE 1016, CSA, UL

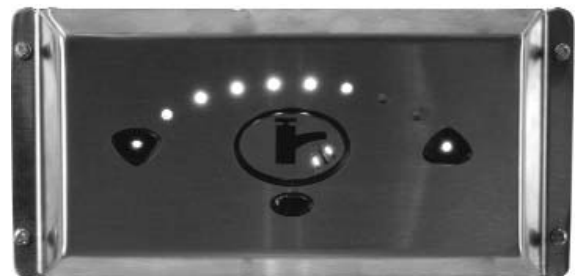

Optional Stainless Steel Control Panel

All dimensions and weights are approximate. Use certified print for exact dimensions. Design and materials are subject to change without notice.