

Armstrong Unfired Steam Generators are designed to produce pressurized clean steam using boiler steam or high temperature hot water as an energy source. Typical uses for this clean steam include humidification, sterilization, pharmaceutical applications and food processing.

Armstrong Unfired Steam Generators are constructed and stamped in accordance with ASME code and bear the UB stamp as required by the ASME code. All tanks are registered with the National Board of Boiler and Pressure Vessel Inspectors and an insurance compliance certificate is furnished. Unfired steam generators that generate 50 psi or greater steam will be 100% x-rayed in accordance with the ASME code.

Armstrong Unfired Steam Generators are carefully designed to provide the correct balance of steaming area, coil size and control components to meet the specified requirements.

Armstrong Unfired Steam Generators include an over pressure safety system that will shut the unit down on loss of electrical power. This over pressure safety system closes both the feed-water and source steam valves shutting the Unfired Steam Generator off.

Basic USG Package Includes:

- ASME Code constructed and National Board Registered Vessel
- 2 inch fiberglass insulation
- 20 gauge steel jacket with hammerstone enamel paint
- Structural I-beam support skid base
- ASME pressure relief valve
- Boiler steam pressure gauge
- Steam separator
- Steam traps - main and auxiliary
- Steam strainer - main
- Steam pressure control valve
- Built In:
 - Remote start stop
 - On-off switch
 - Alarm horn with alarm silence relay
 - Low water cut-off
 - Timer for timed blow down
 - Relay for water feed
 - Operating pressure readout
 - High pressure cut-out and alarm
 - Low pressure alarm
 - LCD display of functions and alarms
 - Power on
 - Low water
 - High water
 - Water feed
 - High pressure
 - Low pressure
 - Blow down operating
- Built in contacts to notify BMS of functions and alarms:
 - Power on
 - Low water
 - High water
 - Water feed
 - High pressure
 - Low pressure
 - Blow down operating
 - Operating pressure

Armstrong Unfired Steam Generators

Output steam pressure is maintained by a modulating source steam valve, which monitors the output steam pressure and varies the input of source steam to maintain a constant output steam pressure. Two types of steam controllers are available.

Pilot Operated

A pilot operated steam controller which uses a steam pilot to monitor output steam pressure and automatically modulate the flow of source steam and maintain a constant output steam pressure. A pilot operated controller is field adjustable.

Pneumatically Operated

A pneumatically operated steam controller uses building air which is connected to a furnished transmitter which monitors the output steam pressure and sends a varying air signal to the source steam controller to modulate the flow of source steam and maintain a constant output steam pressure. A 15 psi minimum air signal is required. Pneumatic set point is field adjustable.

Armstrong Unfired Steam Generators are completely packaged and ready for use. All components are sized, mounted and piped prior to shipment. When supplied with optional equipment for make-up water feeding, these reboilers come complete and require only connections to services. See "Optional Extras".

Optional Extras

Make-up Water Feeding

Make-up water must be furnished to the unfired steam generator.

This can be accomplished by a simple solenoid valve, which opens and closes on a signal from the water level controller. A solenoid feed system requires that there must be at least 10 pounds pressure difference between the steam pressure in the Unfired Steam Generator and the make-up water pressure. If there is less than 15 pounds pressure differential, a feedwater pump must be used.

The second method is to feed the water from a boiler feed pump unit with a condensate tank. The condensate tank is fed with make-up water and condensate. On a signal from the level controller on the Unfired Steam Generator, a pump is started which pumps the make-up water into the Unfired Steam Generator. When the water level in the Unfired Steam Generator is satisfied, an electrical signal from the level controller signals the water feed pump to stop.

A third method of feeding is a feed water pump, which is connected into the city water or make-up water line and is started and stopped on a signal, from the level controller. In all three cases, there should be a check valve in the line between the boiler and the solenoid, condensate feed pump or feed water pump.

Shell

All stainless steel grades furnished are typically T-304 or T-316 as required for the application. In a stainless steel Unfired Steam Generator, all components in contact with clean steam can be constructed of the grade of stainless steel specified.

Submerged Coils

All stainless steel U-bend heating coil rolled into a stainless steel tube sheet.

Piping

All Stainless steel piping on clean steam side

High Pressure Cut Off

Armstrong Unfired Steam Generators are furnished with a high pressure cut off of energy source via solenoid on pilot or incoming air signal. This safety system is designed to prevent the unfired steam generator from generating steam above the desired set point. This solenoid is also wired to the level controller to close the control valve on a low water condition.

Steam Generators with carbon steel shells and copper heat exchangers are available for applications not using ultra-pure feed water. Consult Factory.

Automatic Blowdown - Timer Based Blowdown is Standard (Less Solenoid Valve)

On Unfired Steam Generators using city water there will be an accumulation of mineral build up in the boiler. These minerals must be disposed of by a blowdown system. The blowdown system can be as simple as a manual blowdown where the maintenance person would blow the boiler off manually for a set period for a set frequency. It is advantageous to offer an automatic blowdown system. The simplest automatic blowdown system is one that operates from timers. There is a seven day, 24 hour interval timer and a duration timer connected to a solenoid valve, which will blow the boiler down. The interval timer can be set in frequencies as close as 2 hours and as far apart as once every seven days. This timer will signal a duration timer, which is adjustable from 2 to 180 seconds. The duration timer sends a signal to a solenoid valve, which opens and blows the boiler down. This is a simple system, but requires the owner of the Unfired Steam Generator to do some analysis to determine the correct frequency and duration timer settings.

Automatic Blowdown - TDS Sampling Method

There is a more sophisticated system, which samples the boiler water and blows the boiler down when the dissolved solids exceed a set point. This is a time sample method, which measures the total dissolved solids by opening the blowdown valve for an adjustable time period and measuring the blow off for dissolved solids. If the total dissolved solids exceed the trip point, the motorized valve will remain open until the fresh water make-up dilutes the boiler water to a safe level of total dissolved solids.

Armstrong Unfired Steam Generators—Horizontal

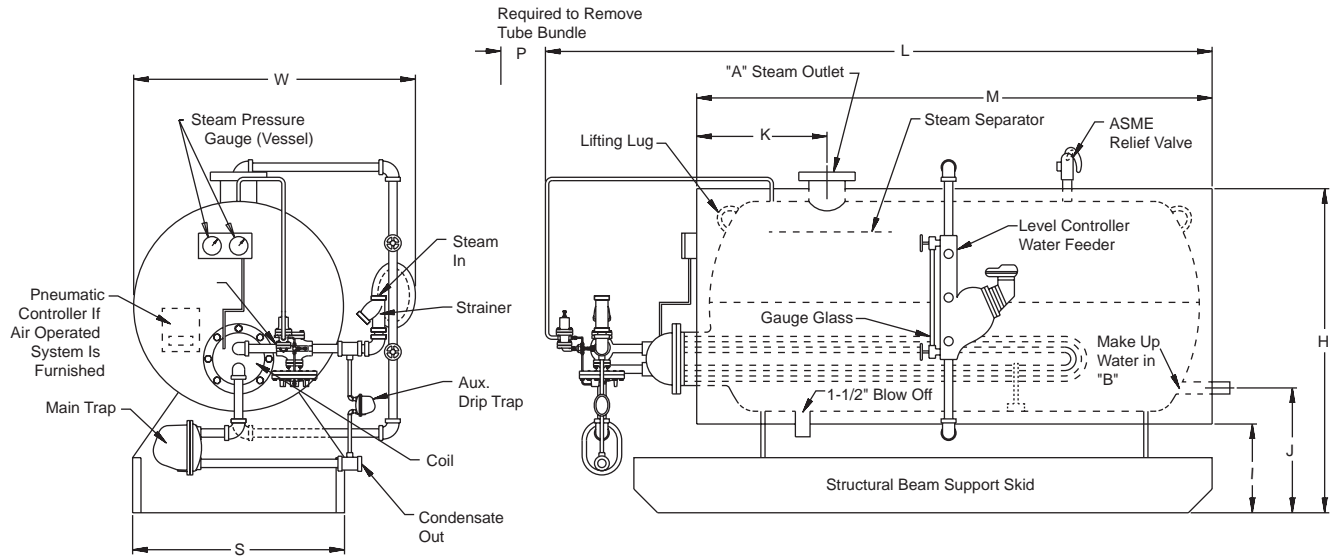

Table 103-1. Dimensions

Model No.	Boiler Vessel Size	W	H	L	S	M	I	J	K	P*	A	B
RB60H	20" x 48"	34"	42"	64"	24"	52"	18"	24"	17"	60"	1-1/2" NPT	3/4"
RB120H	24" x 63"	38"	46"	79"	28"	65"	18"	24"	17"	60"	1-1/2" NPT	3/4"
RB205H	30" x 72"	44"	49"	88"	34"	76"	15"	21"	18"	60"	2" NPT	1"
RB395H	36" x 96"	50"	52"	112"	40"	100"	12"	20"	20"	84"	3" NPT	1"
RB670H	42" x 120"	56"	58"	140"	46"	124"	12"	20"	22"	102"	4" FLG	1-1/2"
RB860H	48" x 120"	62"	64"	140"	52"	124"	12"	20"	24"	102"	5" FLG	2"
RB1085H	54" x 120"	68"	70"	140"	58"	124"	12"	22"	28"	102"	6" FLG	2"
RB1330H	60" x 120"	74"	76"	140"	64"	124"	12"	22"	28"	102"	8" FLG	2"

*This dimension is for the longest coil available, shorter coils with a corresponding shorter "P" dimension are available. Consult factory or your local Armstrong Representative.

All dimensions and weights are approximate. Use certified print for exact dimensions. Design and materials are subject to change without notice.



Armstrong Unfired Steam Generators—Vertical

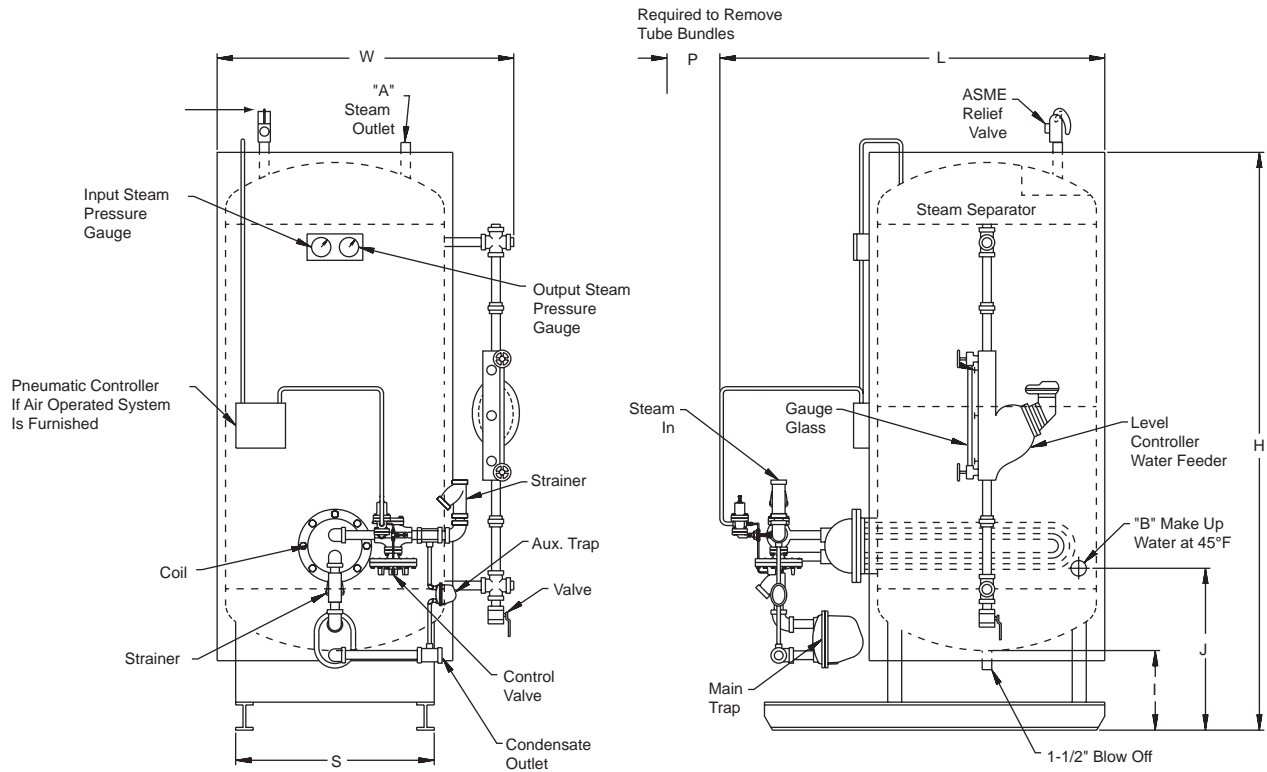

Table 104-1. Dimensions

Model No.	W	H	L	S	I	J	P	A	B
RB45V	34"	54"	36"	20"	12"	20"	10"	1-1/2"	3/4"
RB90V	38"	62"	42"	18"	12"	24"	14"	2"	3/4"
RB160V	44"	74"	48"	21"	12"	28"	20"	3"	1"
RB240V	50"	74"	54"	25"	12"	28"	26"	4" FLG	1"
RB320V	56"	74"	60"	32"	12"	30"	30"	5" FLG	1"
RB410V	62"	74"	66"	42"	12"	30"	38"	6" FLG	1-1/2"
RB510V	68"	74"	72"	44"	12"	31"	44"	8" FLG	1-1/2"

For Steam

To accurately size an Unfired Steam Generator, the following information is required:

1. Source Steam Pressure
2. Output Steam Pressure
3. Make-up Water Temperature
4. Pounds per hour of output steam required

Given this information, Armstrong or its authorized representative can size the Unfired Steam Generator.

All dimensions and weights are approximate. Use certified print for exact dimensions. Design and materials are subject to change without notice.