



Armstrong® Precise control and uniform distribution

Humidifier control must provide immediate response and precise modulation in order to accurately maintain the required relative humidity. Faulty control can lead to overloading the ducts with moisture and the creation of wet spots or failure to provide the required humidity level.

Two design factors affect the accuracy of humidifier control – the metering valve and the actuator that positions the valve.

Precise flow control can be achieved with a valve designed expressly for the purpose of adding steam to air. All Armstrong modulating humidifiers employ unique parabolic plug type valves. See Figure 52-1.

Armstrong uses an exclusive modified plug for the control valve to accomplish this. The modification of true linear characteristics provides more precise control when capacity requirements are

very low and the valve is just cracked off the seat. Notice in Chart 52-1 that at point A on the curve more than half the valve stroke is devoted to 40% of the unit's capacity. At point B, one-quarter of the stroke is devoted to only 10% of capacity. At point C, 10% of the stroke covers less than 5% of the unit's capacity.

How low can the unit control? Table 52-1 tabulates this function, called rangeability. Rangeability is the ratio between the maximum controllable flow and the minimum controllable flow of steam through the valve. The higher the rangeability of a valve, the more accurately it can control steam flow at low outputs.

To calculate this minimum flow, simply multiply Continuous Discharge Capacity by the percentage shown in Table 52-1. **For example**, a 9/32" orifice at 15 psi can discharge 75 lb/hr. The lowest output that can be controlled is 2.5% of 75 or 1 7/8 lb/hr.
Humidifier operators

| Table 52-1. Steam Humidifier Valve Rangeabilities | | | |
|---|--------------------------------|-------------------------|---------------------------|
| Humidifier Models | Valve Equivalent Diameter (IN) | Rangeability | |
| | | Ratio of Flow Max.:Min. | Minimum Flow % of Maximum |
| Model No. 94 | 1-1/2 | 63:1 | 1.6 |
| | 1-1/4 | 69:1 | 1.4 |
| | 1-1/8 | 61:1 | 1.6 |
| | 1 | 53:1 | 1.9 |
| | 7/8 | 44:1 | 2.3 |
| | 3/4 | 33:1 | 3.0 |
| Model No. 93 | 5/8 | 25:1 | 4.0 |
| | 3/4 | 118:1 | 0.8 |
| | 5/8 | 123:1 | 0.8 |
| | 9/16 | 105:1 | 0.9 |
| | 1/2 | 97:1 | 1.0 |
| | 15/32 | 85:1 | 1.2 |
| Model No. 92 | 7/16 | 75:1 | 1.3 |
| | 13/32 | 64:1 | 1.6 |
| | 1/2 | 97:1 | 1.0 |
| Model No. 90, 91 or 92 | 7/16 | 75:1 | 1.3 |
| | 3/8 | 70:1 | 1.4 |
| | 11/32 | 59:1 | 1.7 |
| | 5/16 | 49:1 | 2.0 |
| | 9/32 | 40:1 | 2.5 |
| | 1/4 | 31:1 | 3.2 |
| | 7/32 | 24:1 | 4.2 |
| | 3/16 | 18:1 | 5.6 |
| Model No. 90 or 91 | 5/32 | 59:1 | 1.7 |
| | 1/8 | 37:1 | 2.7 |
| | 7/64 | 28:1 | 3.5 |
| | 3/32 | 21:1 | 4.8 |
| | 5/64 | 15:1 | 6.9 |
| | 1/16 | 10:1 | 10.0 |

Figure 52-1. Parabolic Plug Metering Valve
Parabolic plug valve configuration permits accurate modulation of flow over the complete stroke of the valve.

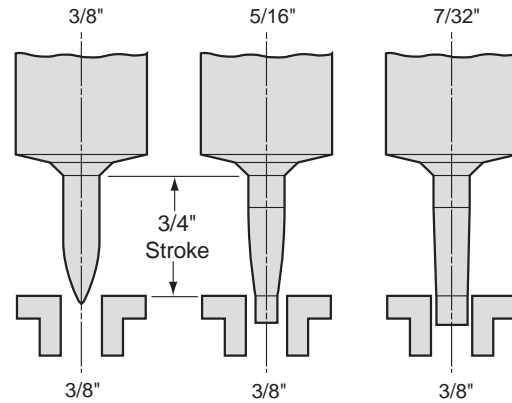
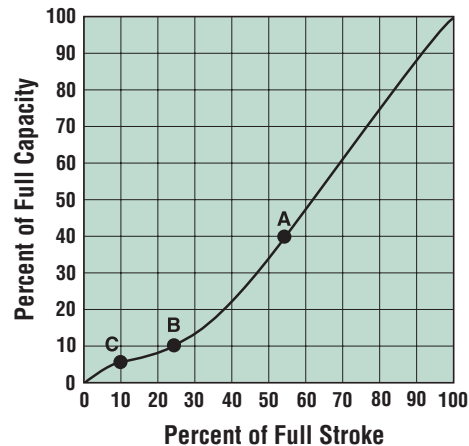

Chart 52-1. Modified linear characteristic curve for valves used under modulating control. The modification of true linear characteristics provides more precise control when capacity requirements are very low and the valve is just cracked off the seat.



All dimensions and weights are approximate. Use certified print for exact dimensions. Design and materials are subject to change without notice.

The operator for the valve is equally important to humidifier control, and several types are available to provide compatibility with the system in which they are installed. The operator must be able to position the valve in very nearly identical relationship to the seat on both opening and closing strokes. This is essential in order to provide consistent, accurate metering of steam discharged by the humidifier.

By their design, electric motor modulating actuators provide true linear positioning characteristics on both opening and closing cycles. Pneumatic operators may or may not be able to provide the precise positioning and holding characteristics essential to accurate control. Rolling diaphragm type pneumatic operators are recommended, providing they meet the following criteria:

1. Large diaphragm area – 12 square inches or more – to provide ample lifting force. This permits the use of a spring heavy enough to stabilize both the hysteresis effect and the flow velocity effect on the positioning of the valve stem versus air pressure to the operator.
2. Diaphragm material that is highly resistant to wear or weakening from continuous cycling and high temperatures.
3. Operator stroke long enough, in conjunction with valve plug and seat design, to provide high rangeability ratios.
4. Easy serviceability.

| Table 53-1. Operator Spring Ranges for Pneumatically Controlled Humidifiers | | | |
|--|--------------------------------|-------------------------|------------------------------------|
| Armstrong C-1801 | | Honeywell MP953D | |
| Operating Range | Adjustable Start Points | Operating Range | Non-adjustable Start Points |
| 5 lbs. | 3 psig minimum | 4 lbs. | 3 psig |
| *10 lbs. | 3 psig minimum | 5 lbs. | 8 psig |
| | | *7 lbs. | 4 psig |

*Standard spring - furnished when no spring range is specified.

All modulating operators, whether electric or pneumatic, should incorporate a spring return. This is necessary to ensure closing of the valve if there is an interruption of power or control air to the unit.

For industrial in-plant operation and for certain very limited duct applications, a solenoid operator may be used to provide simple on/off operation. This type of operator should not be specified for duct applications without a detailed analysis of the system.

Chart 53-2.

Desirable operating characteristic for pneumatic actuators. Position of valve is very nearly identical on both opening and closing strokes at any given air pressure to the actuator.

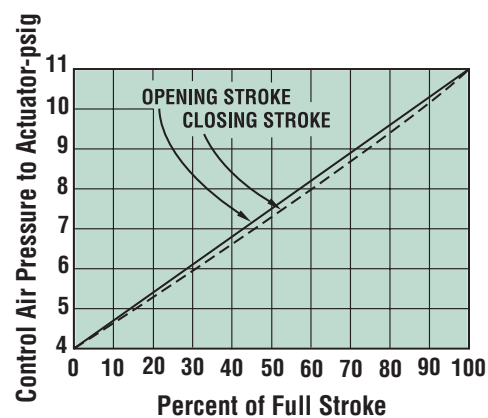

Temperature switches are recommended.

Temperature switches prevent humidifier operation until start-up condensate is drained and the entire unit is up to steam temperature, thus eliminating the possibility of spitting on cold start-up.

Either pneumatic or electric temperature switches are recommended in any system where the steam supply to the manifold jacket and humidifier body may be interrupted or turned off, such as summer cycles. Cold piping downstream of the on/off valves can generate spitting.



Operator Types



Armstrong C-1801 pneumatic operator for humidifiers under modulating control. Adjustable start points and various air pressure ranges. (See Table 53-1, Page 53.)



Standard Honeywell MP953D pneumatic operator for humidifiers under modulating control. Operating spring ranges and start points are shown in Table 53-1, Page 53. Operational start point adjustment is available in the form of a pilot positioner where required.



Standard electric operator for humidifiers under modulating electrical control. Choice of Honeywell M9182A operator (shown above 24V 60Hz), or Belimo AF24SR (24V 60 Hz), or Belimo NVF24 (shown below, 24V 60Hz standard). Transformers for other voltages available for all electric operators.



Standard ASCO electric solenoid operator for humidifiers under on-off control. **Caution:** On-off operation of humidifiers in air handling systems is advisable only for very limited, specialized applications. Consult your Armstrong Representative.

Humidifier operators in stock

1. Pneumatic Modulating

- Armstrong C-1801
- Honeywell M953D and F
- Invensys MK4421 and MK4411

2. Electric Modulating

- Honeywell M9182A
- Belimo AF24SR
NVF24

3. Solenoid

- Asco Class H Coil

Additional Humidifier operators that have been installed on Armstrong humidifiers*

1. Pneumatic Modulating

- Invensys MK-4411, 4421

- Johnson. PA 20/150

- Sauter AV42P10 with XSP31 positioner

Note: Please consult Armstrong for choice of pneumatic actuator on 94 size humidifier when steam pressure is above 30 psig.

2. Electric Modulating

- Invensys MP-361, MP-461

- Belimo AF24SR, NVF24

- Landis & Gyr and Staefa. . . SKD62

Note: Any operator with a reverse acting (lift to open) 3/4" stroke and spring return can usually be adapted. Consult factory for details.

*Request Armstrong Application Guideline APP-505 for details on control signal and power requirements.

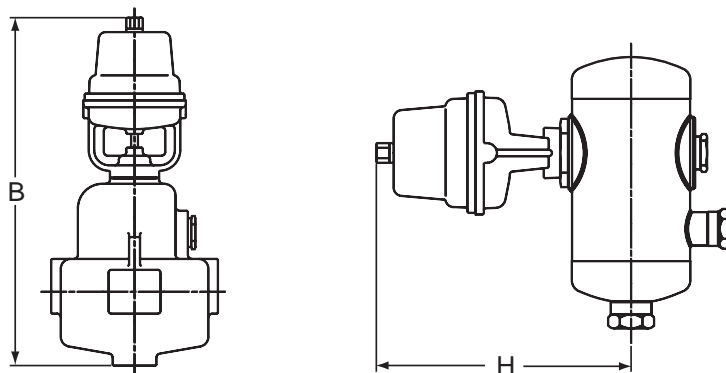
Table 55-1. Dimensions with Operators Installed

| Mode of Control | Pneumatic Modulating | | | Electric Modulating | | | Electric On-Off |
|--------------------|----------------------|------------------|--------------------------|---------------------|---------------|-----------------------|-----------------|
| | Armstrong C-1801 | Honeywell MP953D | Invensys MK4411 & MK4421 | Honeywell M9182A | Belimo AF24SR | Belimo NVF24-MFT-US-E | ASCO |
| "B" - 90 Size | 11-7/8" | 10-3/8" | 14-7/8" | 14-7/8" | 18-1/2" | 15" | 7" |
| 91 Size | 16" | 14-1/2" | 19" | 18-7/8" | 22-11/16" | 18-15/16" | 10-7/8" |
| 92 Size | 16" | 14-1/2" | 19" | 18-7/8" | 22-11/16" | 18-15/16" | 10-7/8" |
| 93 Size | 19-1/2" | 17-7/8" | 22-3/16" | 22-1/8" | 26-3/16" | 22-1/4" | 14-1/2" |
| 94 Size | — | 24-1/2" | — | 27-7/8" | 31-1/16" | 27-7/16" | — |
| "H" - 1100 Size | 9-3/8" | 8" | 12-1/2" | 13" | 16-1/16" | 14-9/16" | 4-3/8" |
| 1200 Size | 9-9/16" | 8-3/16" | 12-9/16" | 13-3/16" | 16-1/4" | 14-3/4" | 4-9/16" |
| 1300 Size | 10-3/4" | 9-1/4" | 13-3/4" | 14-1/4" | 17-5/16" | 15-13/16" | 5-5/8" |
| 1400 Size | — | 11-5/16" | 15-3/4" | 16-5/16" | 19-3/8" | — | — |
| Weight of Operator | 7-3/4 lbs. | 6 lbs. | 6-1/4 lbs. | 12 lbs. | 13 lbs. | 4-1/4 lbs. | 3/4 lbs. |

All dimensions and weights are approximate. Use certified print for exact dimensions. Design and materials are subject to change without notice.