



Series EHU-700 Electronic Steam Humidifier

Accurate Humidity Control with Virtually No Manual Adjustment



The Armstrong EHU wraps up accurate control and reliability in a well-designed package that's just too smart to be imitated. No other electronic humidifier does a better job of stabilizing and simplifying humidity control. That's because only Armstrong offers full modulation and a patented self-regulating maximum output feature. It's an exclusive combination—and powerful peace of mind when it comes to humidification.

When you install an Armstrong Series EHU Electronic Steam Humidifier, you can forget about tiresome manual adjustment and messy trial-and-error maintenance. A free videotape (available upon request) clearly explains proper installation, operation and maintenance procedures. So you get accurate, automatically adjusted humidity control that's virtually hands-free.

Self-Diagnostics. Now, That's Smart...

Very sensible indeed. Internal software routines automatically monitor the operation of the HumidiMinder and display messages to indicate the condition. The unit will report on 10 different conditions.

The Series EHU Humidifiers come in conveniently sized models. The largest provides steam output up to 240 lb/hr. No matter which unit you choose, you'll get the benefits of Armstrong's more than 60 plus years of problem solving experience in steam humidification.

...And Sensible Protection, Too

Accurate, reliable humidity control is a sensible precaution to protect your investment in materials, equipment and personnel. Increasing the temperature of indoor air without adding moisture decreases its relative humidity (RH). And when RH falls to levels commonly found in heated indoor environments, moisture-retaining materials such as wood, paper, textile fibers and a wide range of food and chemicals begin to deteriorate.

Dry air can also increase static electricity buildup, which may actually sabotage production and office equipment. Computer rooms, printing operations, clean rooms and laboratories are especially sensitive to static charges due to parched air.

When humidity levels are not properly controlled, indoor air quality also suffers. According to ASHRAE Standard 62-1999 on indoor air quality: "...Relative humidity in habitable spaces preferably should be maintained between 30% and 60% relative humidity... Steam is preferred as a moisture source for humidifiers but care should be exercised to avoid contamination from boiler water or steam supply additives."

Indoor air quality, proper control of moisture output, efficiency and ease of maintenance. Since steam scores high on all of these factors, a steam humidifier is clearly the best choice. And an Armstrong EHU may just be the smartest.

All dimensions and weights are approximate. Use certified print for exact dimensions. Design and materials are subject to change without notice.

How the Series EHU-700 Works

An Armstrong Series EHU converts ordinary tap water to steam and distributes it to bring the relative humidity up to the desired level. It's ideal for providing humidification where no steam is available or where a steam source is too remote for easy or economical piping.

The humidity demand, sensed by the humidistat, is indicated by the EHU demand display. A microprocessor converts this demand signal into an amperage requirement. The internal power contactor closes, applying voltage to the electrodes, and the fill valve begins to fill the tank.

Water enters the bottom of the steam generator tank and rises until it reaches the electrodes. Upon contact, electrical current flows through the water, causing it to boil and produce steam (Figure 137-1).

When the water level rises, as shown in Figure 137-2, increased electrical current flows through the water, producing more steam. This increase will continue until the required output of steam (i.e. amperage requirement) is reached.

At this point, the fill valve will cycle to maintain the required amperage. When the humidistat senses the added moisture in the air, the demand for humidity begins to drop. As the demand falls, the output of the unit modulates down by decreasing amperage, and therefore steam flow. The fill valve can then cycle at the lower steam output (amperage) requirement.

Figure 137-3 shows what happens when the humidistat demand signal drops below a minimum demand: The contactor is de-energized, and steam output stops.

A duct high-limit humidistat or an air flow interlock switch may also stop steam output. These devices prevent excess moisture and condensation in the duct. The Series EHU may also be used in combination with an Armstrong EHF-2 or EHF-3 Fan Package for direct area discharge of steam. A high-water float switch prevents water carryover into the duct due to too high a water level in the tank. An automatic drain cycle blows down mineral-laden water to extend tank life and reduce maintenance. An overcurrent protection circuit will drain water from the tank to reduce current flow and then de-energize the contactor to stop current flow if overcurrent still exists. After a period of no demand on the Series EHU-700, an "End of Season" drain is initiated to eliminate the potential for stagnant water to remain in the tank.

Figure 137-1. 100% demand. Filling with water. Low, increasing steam output.

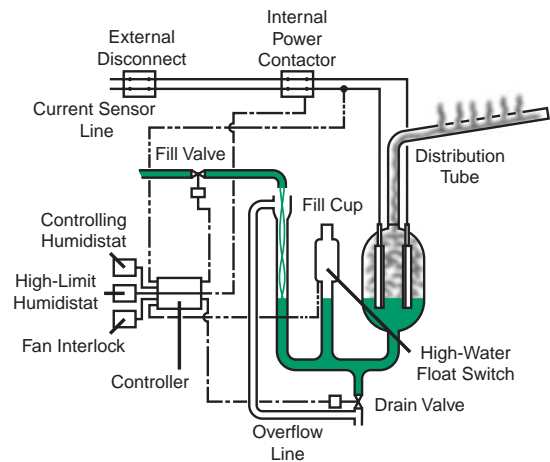

Figure 137-2. 100% demand. Fill valve cycling to maintain output. High water level. High, constant steam output.

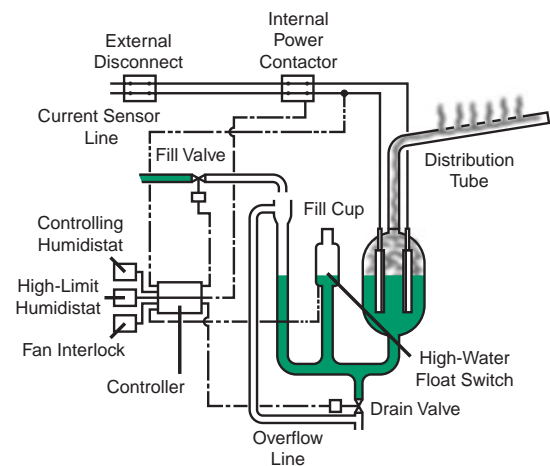
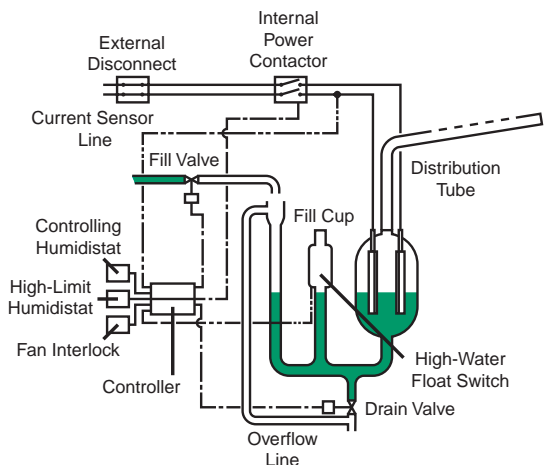

Figure 137-3. No demand. Contactor opens. No steam output.



■ Steam ■ Water



Self-Regulation Makes the Armstrong Series EHU-700 a Smart Choice

Standard full modulation stabilizes humidity.

As room humidity changes, the Series EHU-700 steam output changes to maintain set point. Since output varies with water level, the unit need only adjust the tank water level to achieve continuous modulating output (from 10% to 100% of capacity). Less efficient units simply turn on and off via a contactor in response to room changes. Due to its unique full modulating control feature, the output of the Armstrong Series EHU-700 is continuously adjusted to satisfy the necessary humidity requirements. Modulating control also means gradual increases in amperage.

Exclusive patented self-regulating maximum output improves control and consistency.

In low-demand situations, oversized units quickly shut down because a fraction of the output satisfies the requirement. This on/off behavior is called "hunting" because the unit never finds its set point. The EHU automatically adjusts maximum output in response to the operating history of the demand signal to virtually eliminate "hunting." Working in conjunction with full modulation, this feature provides better control under varying demands—with no manual adjustment of maximum output required. See Chart 138-1.

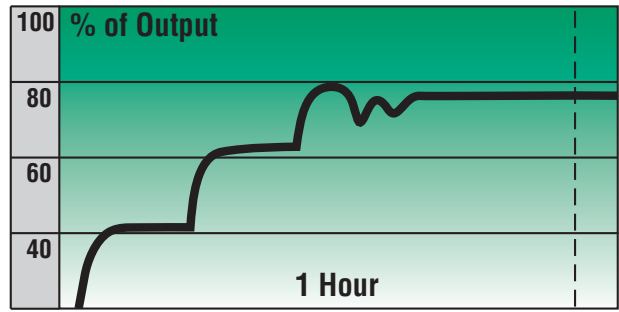

Chart 138-1. This chart represents the patented self-regulating maximum output of the EHU Series from start-up. To avoid hunting, the unit gradually increases capacity from 40% of maximum to 60% to 80%. In this case, the output satisfies the humidistat demand at a level below 80% of maximum capacity. The modulating feature then takes over and controls the unit output. The self-regulating maximum output can then adjust up (to 100% in this example) or down (to 60%) as demand history warrants. The feature intermittently "resizes" the humidifier's maximum capacity to avoid hunting and to provide humidity control.

As we have seen, Series EHU-700 makes steam from ordinary tap water. That's why they're ideal for humidification when no steam source exists or when providing a steam humidifier would be too impractical or costly. They're also ideal because they come with built-in Armstrong reliability, convenience and efficiency. See for yourself.

Clean steam discharge to duct manifold

Fill cup with integral air gap prevent backflow into water supply

Locking cabinet prevents tampering

Lightweight steam generator is repairable or replaceable

Large ported single drain connection (on single tank units)

Inlet strainer protects fill valve



Standard built-in diagnostics simplify maintenance, eliminate guesswork.

Internal software routines constantly monitor operating history of the EHU to detect patterns of abnormal operation. For the Series EHU-700, standard built-in diagnostics detect small problems before they become big ones so you can minimize the cost and expense of repair and cleaning. And in the event of a serious malfunction—a plugged drain line, for example—the unit is designed to attempt corrections before automatically shutting down.

Cleanable tank combines economical maintenance and convenience.

You can easily disassemble and inspect the Series EHU-700's steam generating tank. And thanks to the Dirty Tank Indicator, you'll know when to do so. Software routines analyze the operating history of the Series EHU-700 over a long period of time to detect conditions that indicate a need for tank cleaning. When it is necessary, you have the option to clean the tank or replace it entirely.

Adapts easily to humidistat signals so it saves you money.

The standard unit includes the Armstrong modulating control humidistat. You can easily adjust the unit in the field to accept any of the following common control signals: on/off (SPST relay), 1.9-3.9 Vdc, 4-20 milliamp or 0-10Vdc as the main control signal. Additional input terminals are provided for on/off air flow and duct high-limit humidity controls. Advanced controls include a VAV controls package that can include a modulating high limit humidistat and outdoor temperature reset. The setpoint can be adjusted by a dial on the front cover.

Automatic drain timer balances efficiency and long operating life.

The Series EHU-700 automatically varies tank flushing based on the operating history and the water's mineral content (conductivity). The result? Positive, self-regulating mineral control that responds automatically to changes in mineral accumulation caused by changing water supply or water consumption due to varying steam output. For you, that means simple operation—no controls to set, no seasonal adjustment—and a long, efficient service life.

Why the Series EHU-700 is Easier to Troubleshoot and Maintain

Running diagnostics.

Standard software routines continually monitor operation and display coded messages indicating the condition.

Connections to an external alarm circuit are provided. Under "alarm" conditions noted, a relay contact closes, allowing activation of an external Class 2 device.

Input/Output (I/O) diagnostics.

Installation errors account for most start-up problems. The I/O circuit diagnostics can help pinpoint simple problems and avoid unnecessary service calls.

Installation/Operation Video.

A free video tape is available to help ensure proper installation, operation and maintenance. Contact factory.

Display	Interpretation	Unit Response
C00	Normal operation	
C01	High-water condition	Stop water fill
C02	Tank needs cleaning	Alarm
C03	Interlock circuit open	Power off to tank
C04	High-limit stat open	Power off to tank
C05	Drain system malfunction	Alarm and shutdown
C06	Fill system malfunction	Alarm and shutdown
C07	Overcurrent malfunction	Alarm and shutdown
C08	Manual tank shutoff	Power off to tank
C09	I/O diagnostics	Perform I/O display

Engage the I/O diagnostics by pressing "Mode Select" switch until "Diagnostic" mode indicator light illuminates. In sequence, the unit will automatically:

1. Actuate the fill valve, drain valve, contactor and the related indicator lights.
2. Read and display the controlling stat signal as a percentage of demand.
3. Check the interlock and high-limit stat circuits and display any fault conditions.
4. Return to previous operation condition and display % humidistat demand.

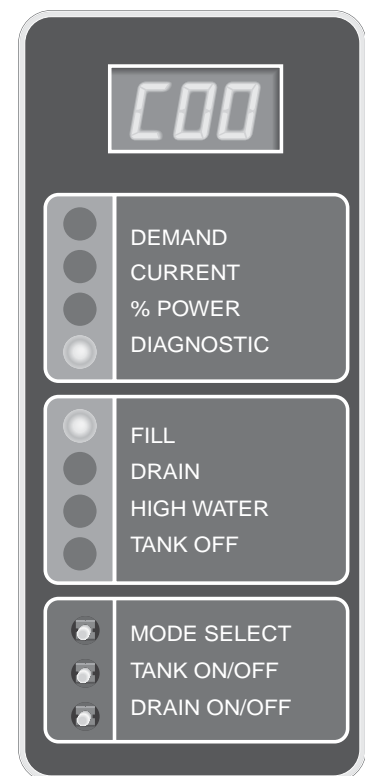

The Series EHU-700 is designed to provide maximum flexibility for steam distribution. Steam can be distributed through an air-handling system (normally an existing air duct) or directly into the area being humidified with the Armstrong EHF fan packages.

Duct-type distribution.

Where an existing air duct system is available, steam can be introduced into the duct through steam dispersion tube(s). (See Figure 140-2.)

The selection of the steam dispersion tube(s) should meet the duct requirements as noted in Table 140-1. As an example, if the air duct in which you are installing the humidifier has a width between 17" and 22", you should use steam dispersion tube Model D-1.5. If the steam dispersion tube would be located below the humidifier (see Figure 140-3), install a drip leg with water seal.

Area distribution method.

The Armstrong EHF fan packages provide humidity distribution where an air-handling duct system is not available. The attractive EHF-2 unit may be installed directly on top of the

Model EHU-600 or EHU-701 humidifier. The EHF-3 is designed to be direct mounted on a EHU-703. The EHF-2 and EHF-3 units may be hung on a wall and used in conjunction with any appropriate EHU humidifier.

The maximum humidity dispersion capacity of each EHF-2 area fan package is 30 lbs/hr (14 kg/hr). It incorporates a blower rated at 115 V-1.3 amp. CFM rating is 280 CFM @ 1,380 RPM.

The maximum humidity dispersion capacity of the EHF-3 unit is 120 lbs/hr (54 kg/hr). It incorporates a blower rated at 120 V-2.90 amp. CFM rating is 465 CFM @ 1,530 RPM.

The EHF-2 fan unit has an on-off switch that connects to the EHU and turns the humidifier on when the fan is on.

Note: The EHF-2 fan unit requires a separate 120 V power supply. The electrical power supply of the EHF-2 does not connect into the EHU humidifier.

The EHF-3 can be used (upon request) with power supplied to the EHU through a step-down transformer.

Figure 140-1. EHU Dispersion Tube and EHU Dispersion Tube with Drain Tube.

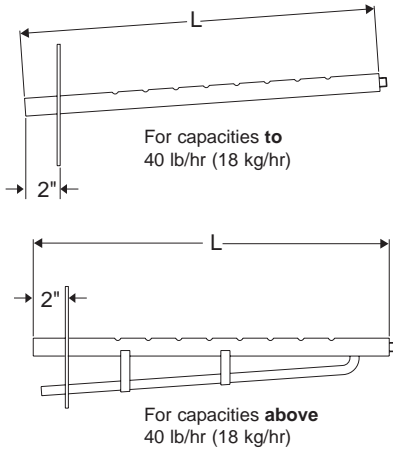

Figure 140-2. Duct-type distribution.

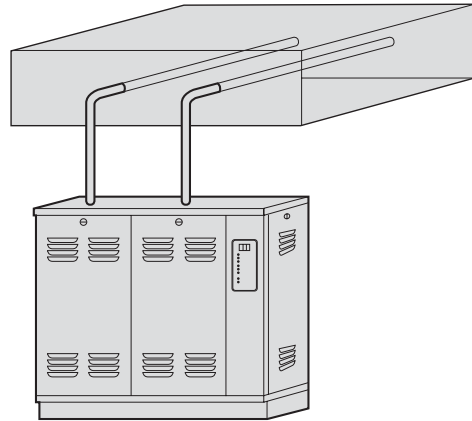
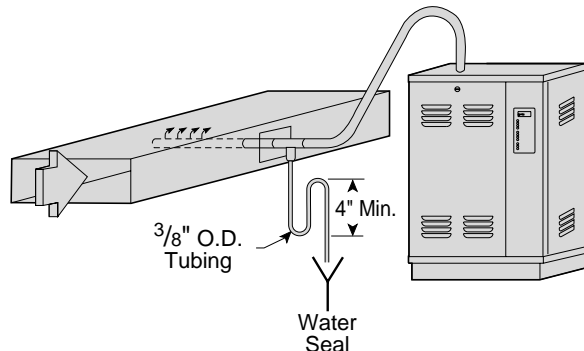

Table 140-1. Selecting Proper Steam Dispersion Tube

Steam Disp. Tube Model No.	Steam Disp. Tube Length		Duct Width				Weight	
	in	mm	Min.		Max.		lb	kg
D-1	12	304	11	279	16	406	3	1.4
D-1.5	18	457	17	432	22	559	3	1.4
D-2	24	609	23	584	34	864	4	2
D-3	36	914	35	889	46	1168	6	3
D-4	48	1219	47	1194	58	1473	8	3.6
D-5	60	1524	59	1499	70	1778	9	4
D-6	72	1829	71	1803	82	2083	10	4.5
D-7	84	2133	83	2108	94	2388	11	5
D-8	96	2438	95	2413	106	2693	12	5.5
D-9	108	2743	107	2718	118	2998	13	6
D-10	120	3048	119	3023	130	3302	14	6.4

See Figure 140-1. When unit has maximum capacity of above 40 lbs/hr (18 kg/hr), use steam dispersion tube with 1/2" drain.

Figure 140-3. Model EHU-703 with steam dispersion tube located below humidifier.



All dimensions and weights are approximate. Use certified print for exact dimensions. Design and materials are subject to change without notice.

Selection and Ordering Procedures for Series EHU-700



The following factors must be considered in the selection and ordering of the proper unit.

1. Capacity required.

You must compute the maximum amount of moisture required to determine which size unit is necessary.

Refer to the Humidification Engineering section of this catalog or Armstrong's Humid-A-ware™ Humidification Sizing and Selection Software (can be downloaded at www.armstronginternational.com) for detailed information on calculating humidification loads. Humidification loads are generally sized on a worst case basis where design conditions exist for a limited time, and do not require a safety factor. Output ratings for EHU humidifiers are average output. It is normal for steam output to decrease during and immediately following drain cycles. Consult your Armstrong Representative or the factory if this poses a control problem for your system.

Example: Assume the humidification load is 45 lbs/hr, and the available power supply is 480 V 3-phase. Starting at the top of the capacity table (Table 142-1, Page 142) and going down the 480 V column, we find the EHU-703 is required. Reading to the left, we find that current module CM 20 is needed, and the branch circuit should be rated for 25 amps.

2. Specify electric characteristics of unit required.

Specify the voltage, phase and cycles for unit on the order. Total amperage must be determined for installation purposes. (See Capacity Table 142-1, Page 142.)

3. Standard humidistat sensing range is 10-90% RH.

Specify room- or duct-type humidistat. Or you may provide your own humidistat and/or controller.

4. Use proper connecting materials.

Two short hose cuffs are provided (four with the EHU-704) to be used with hard copper tube to connect the generator tank to the steam dispersion tube. Armstrong recommends using insu-

lated copper tubing. If requested, flexible hose is available (for model EHU-701) in 10-foot lengths for installations which require flexibility. **The maximum recommended distance for running copper tubing is 40 feet equivalent pipe length. See Bulletin 527 for additional information.**

5. Specify spare steam generator.

If the humidifier is going to be in continuous service on a year round basis, Armstrong recommends the purchase of a spare steam generator to minimize the service interruption during inspection or cleaning.

Duct Unit

6. Specify steam dispersion tube (Table 140-1, Page 140).

Select the proper steam dispersion tube that meets the duct requirements. As an example, if the air duct in which you are installing the humidifier has a width between 17" and 22", you should use steam dispersion tube Model D-1.5.

7. Specify options required:

■ Duct high-limit stat (recommended). You may order a duct high-limit stat. A typical setting for the high-limit stat is 85 percent RH. Stat opens when relative humidity exceeds setting.

■ Fan interlock (recommended). A duct pressure switch may be ordered to activate the humidifier by sensing airflow in a duct system. The pressure switch prevents humidifier operation if there is insufficient air movement in the duct system.

Note: Please contact factory for duct applications offering high static pressure (>4" WC) or velocities over 2000 FPM. Avoid placing dispersion tube in downward, high velocity airflow.

Area Unit

8. Specify the EHF fan package.

Be sure fan package's capacity matches unit's capacity.
EHF-2 up to 30 lbs/hr (14 kg/hr).
EHF-3 up to 120 lbs/hr (54 kg/hr).

Figure 141-1. EHF-2 fan package mounted on EHU-701.

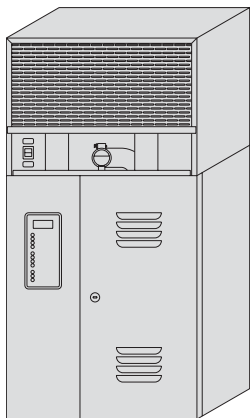

Figure 141-2. EHF-3 fan package mounted on wall above EHU-703.

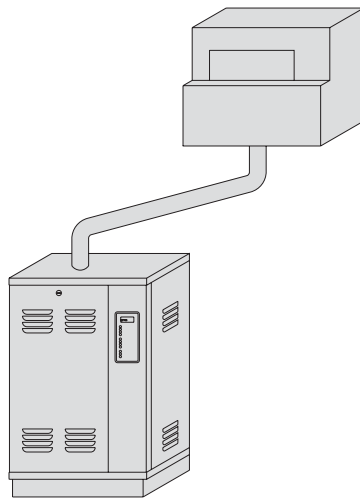
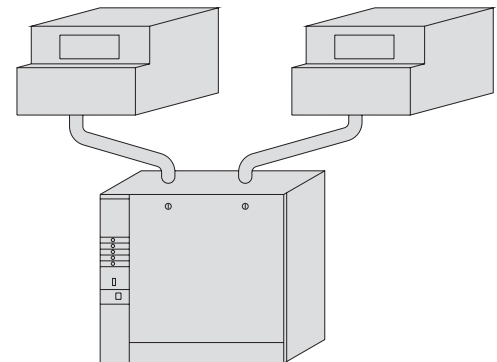

Figure 141-3. Two EHF-3 fan packages mounted on wall above EHU-704.





Armstrong® Series EHU-700 Capacities and Electrical Ratings

Table 142-1. Series EHU-700 Capacities and Electrical Ratings

Nom Amp Rating	Current Module	Recommended Branch Circuit		Output Per Hour @ Voltage Shown																					
		Wire	Circuit Breaker	Single Phase								Three Phase													
				120		208		240		277		208		240		346 ¹		380		415 ²		480		600	
				lb	kg	lb	kg	lb	kg	lb	kg	lb	kg	lb	kg	lb	kg	lb	kg	lb	kg	lb	kg	lb	kg
EHU-701 Humidifier (One Small Steam Generator)																									
7	CM 7	14	15	2	0.9	4	1.8	5	2.3	6	2.7	7	3.2	8	3.6	12	5.4	13	6	15	6.8	17	7.7	21	9.5
12	CM 12	14	15	4	1.8	7	3.2	8	3.6	10	4.5	12	5.4	14	6.3	21	9.5	23	10.4	25	11.3	29	13.2	36	16.3
14	CM 14	12	20	5	2.3	8	3.6	10	4.5	11	5	15	6.8	17	7.7	24	10.9	27	12.2	29	13.2	34	15.4	42	19
16	CM 16	12	20	6	2.7	10	4.5	11	5	13	6	17	7.7	19	8.6	28	12.7	30	13.6	33	15	38	17.2	—	—
20	CM 20	10	25	—	—	12	5.4	14	6.3	16	7.3	21	9.5	24	10.9	35	15.9	38	17.2	42	19	—	—	—	—
24	CM 24	10	30	—	—	14	6.3	17	7.7	19	8.6	25	11.3	29	13.2	42	19	—	—	—	—	—	—	—	—
32	CM 32	8	40	—	—	19	8.6	22	10	26	11.8	33	15	38	17.2	—	—	—	—	—	—	—	—	—	—
40	CM 40	8	50	—	—	24	10.9	28	12.7	32	14.5	42	19	—	—	—	—	—	—	—	—	—	—	—	—
EHU-703 Humidifier (One Large Steam Generator)																									
20	CM 20	10	25	—	—	12	5.4	14	6.3	16	7.3	21	9.5	24	10.9	35	15.9	38	17.2	42	19	48	21.8	60	27.2
24	CM 24	10	30	—	—	14	6.3	17	7.7	19	8.6	25	11.3	29	13.2	42	19	46	20.9	50	22.7	58	26.3	72	32.7
32	CM 32	8	40	—	—	19	8.6	22	10	26	11.8	33	15	38	17.2	55	24.9	61	27.7	66	29.9	77	34.9	96	43.5
40	CM 40	8	50	—	—	24	10.9	28	12.7	32	14.5	42	19	48	21.8	69	31.3	76	34.5	83	37.6	96	43.5	120	54.4
48	CM 48	6	60	—	—	29	13.2	33	15	39	17.7	50	22.7	58	26.3	83	37.6	91	41.3	100	45.4	115	52.2	—	—
EHU-704 Humidifier (Two Large Steam Generators)																									
40	CM 20	8	50	—	—	24	10.9	28	12.7	32	14.5	42	19	48	21.8	69	31.3	76	34.5	83	37.6	96	43.5	120	54.4
48	CM 24	6	60	—	—	29	13.2	33	15	39	17.7	50	22.7	58	26.3	83	37.6	91	41.3	100	45.4	115	52.2	144	65.3
64	CM 32	4	80	—	—	39	17.7	45	20.4	51	23.1	67	30.4	77	34.9	111	50.3	122	55.3	133	60.3	154	69.8	192	87.1
80	CM 40	3	100	—	—	48	21.8	56	25.4	64	29	83	37.6	96	43.5	138	62.6	152	68.9	166	75.3	192	87.1	240	108.8
96	CM 48	2	125	—	—	58	26.3	67	30.4	77	34.9	100	45.4	115	52.2	166	75.3	182	82.5	199	90.2	230	104.3	—	—

NOTES: ¹ 346 Volt units require 346/200 volt 4-wire system.
² 415 volt require 415/240 volt 4-wire system.
KW rating = humidity output (lbs/hr) x 0.345 (for energy calculations only; not for branch circuit sizing).

All dimensions and weights are approximate. Use certified print for exact dimensions. Design and materials are subject to change without notice.

Suggested Specification for Series EHU-700



Steam humidifier for distribution of humidity (steam vapor) into air-handling system or directly into space shall be of the self-contained, electrically controlled design.

- A. Humidifier shall generate steam from ordinary tap water.
- B. Humidifier(s) shall have all internal components contained in a steel cabinet with a key-locked access door to prevent unauthorized access.
- C. Humidifier shall have modulating control to provide 10% to 100% capacity.
- D. Maximum capacity of humidifier shall self regulate with no manual adjustment.
- E. Humidifier shall have tanks that can be taken apart for inspection, cleaning and, if needed, repair. Alternatively, the same tank can be disposed of and replaced. The humidifier shall monitor the tank and the display will indicate when it is dirty and needs cleaning or replacing.
- F. Drain cycle will be self regulating both in frequency and duration to maximize tank life while minimizing energy waste. The drain cycle will automatically control mineral buildup based on water conductivity, humidity demand history and steam output rate. Drain water will be tempered by the fill valve.
- G. Humidifier shall include "End of Season" drain.
- H. Humidifier shall have programmed diagnostics to display input and output circuit status.
- I. Humidifier shall have continuous self diagnostics checking to monitor the operation of the unit. The unit will shut down the tank (current to electrodes) to prevent unsafe operation and a visual display code will indicate cause of failure. Causes of failure include drain system malfunction, fill system malfunction and overcurrent malfunction.
- J. Humidifier shall incorporate a high-water float switch to mechanically sense a high-water condition. A high-water probe that electrically senses high water will not be acceptable.
- K. Humidifier will provide a relay contact closure to indicate a system failure or dirty tank condition. The contact closure will allow for activation of an external Class 2 alarm device (customer supplied). Circuit is rated to 1 ampere.
- L. Humidifier will have a digital display to monitor unit amperage draw, humidistat demand percentage, steam output (as a percentage) and diagnostic codes. The display mode will be user selectable. Lights will indicate fill and drain valves operation, tank off, high water and display mode selected.
- M. The humidifier fill water line(s) shall have an air gap to prevent backflow (siphoning) of contaminated water into the water supply system.
- N. Humidifier shall incorporate electrical terminals for installation of controlling stat, duct high-limit stat, fan interlock switch, and Class 2 alarm device.
- O. Humidifier shall be supplied with stainless steel steam dispersion tube(s) which provide uniform steam distribution over the entire tube length and shall be supplied at various lengths (through 10') to adequately span the widest dimension of the duct.
- P. When applicable, humidifier(s) shall have provisions for discharging steam vapor directly into room area using factory available fan distribution units as an accessory. These units shall be designed for either remote mounting or fit directly on top of humidifier.
- Q. Humidifier shall be supplied with two hose cuffs for connection to hard copper tube (customer supplied).
- R. Humidifier shall be supplied with a humidistat capable of modulating the steam flow, or be capable of working with the following common control signals without factory modification: 2-10 Vdc, 4-20 milliamp and on/off control (SPST relay).

All dimensions and weights are approximate. Use certified print for exact dimensions. Design and materials are subject to change without notice.



Armstrong® Dimensional Drawings and Physical Data for Series EHU-700

Materials	EHU-701	EHU-703	EHU-704	
Generator Tank	Polypropylene			
Cabinet Material	16 ga Steel	16 ga Top & Bottom; 18 ga Sides; Steel		
Cabinet Finish	Baked-On Epoxy Enamel Coating			
Electrodes	Type 430 Stainless	Galvanized Carbon Steel		
Hose Cuffs	EPDM (Ethylene Propylene) Rubber			
Dispersion Tube	Type 18-8 Stainless Steel			
Duct Model				
Dispersion Tube	Type 18-8 Stainless Steel			
Area Fan Unit Model EHF-2 and 3				
Cabinet	Steel - 18 ga. with Epoxy Enamel Coating			
Blower Fan EHF-2	120 VAC, 60 Hz., 1.3 amp 280 CFM @ 1,380 RPM			
Blower Fan EHF-3	120 VAC, 50/60 Hz., 2.9 amp 465 CFM @ 1,530 RPM*			
Weights				
Model No.	Approximate Shipping Weight		Maximum Operating Weight	
EHU-701	60 lb	27 kg	80 lb	36 kg
EHU-703	83 lb	38 kg	113 lb	51 kg
EHU-704	95 lb	43 kg	158 lb	72 kg
EHF-2 Package	33 lb	15 kg	32 lb	15 kg
EHF-3 Package	34 lb	15 kg	33 lb	15 kg

*208, 240, 480 and 600 VAC available

	EHU-701		EHU-703		EHU-704	
	in	mm	in	mm	in	mm
"A" Width	18	457	19-1/2	495	33-1/2	851
"B" Height	23	584	31	787	31	787
"C" Depth	11-1/2	292	14	356	14	356
"D" Tank Drain (Side)	6-5/8	168	3-1/4	83	3-1/4	83
"E" Tank Drain (Front)	10-5/16	262	14-3/4	375	14-3/4	375
"G" Tank #2 Drain	N/A	N/A	N/A	N/A	28-3/4	730
"H" Steam Outlet #1	12-1/2	318	12-1/2	318	12-1/2	318
"I" Steam Outlet #2	N/A	N/A	N/A	N/A	14	356
"J" Supply Water (Side)*	8-1/4	210	9-1/4	235	9-1/4	235
"K" Supply Water (Front)	15-1/2	394	3-3/4	95	3-3/4	95
"L" Electrical Power (Side)	3-1/8	79	2	51	2	51
"M" Electrical Power (Front)	4-1/2	114	2-1/2	64	2-1/2	64
"N" Fan Height (EHF-2)	13	330	N/A	N/A	N/A	N/A
"N" Fan Height (EHF-3)	16	406	16	406	16	406

*Water connection is 3/8" (10 mm) copper compression fitting.

Figure 144-1. General Installation Concept

Electronic steam humidifiers must be installed in locations that allow routine inspection and accessibility for maintenance operations.

Do not place electronic steam humidifiers in locations where unusual instances of malfunction of the humidifier or the system might cause damage to non-repairable, unreplaceable, or priceless property.

Proper installation of electronic steam humidifiers discharging to air handling systems should always include a high limit humidistat and an air proving switch or fan interlock.

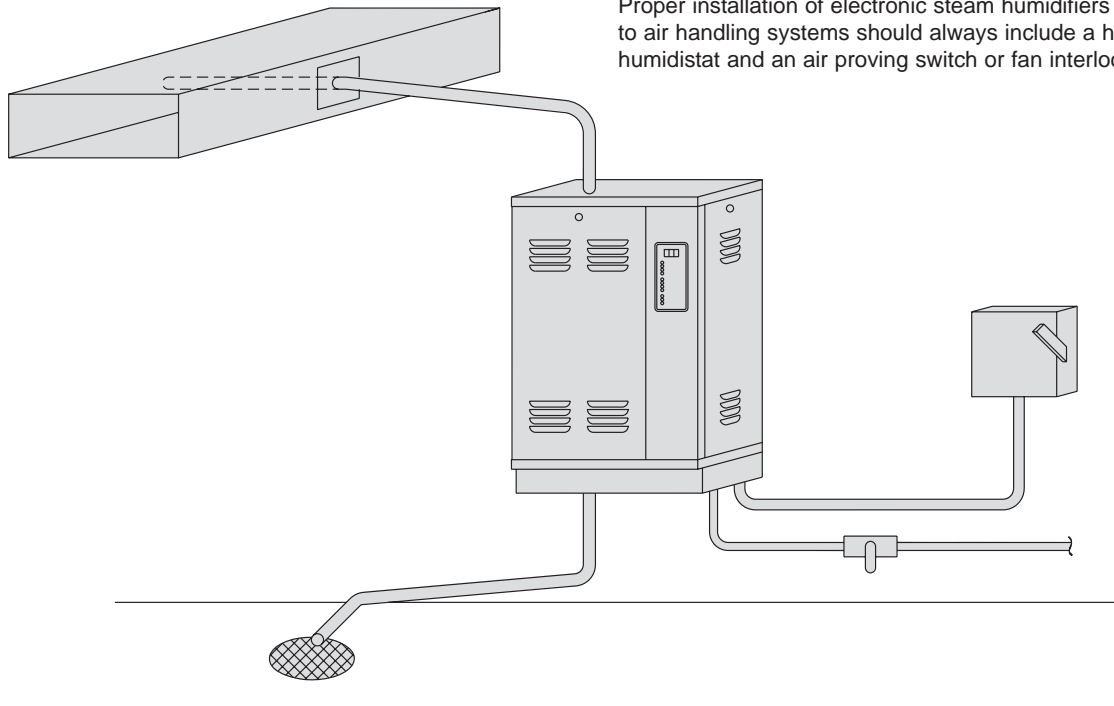

All dimensions and weights are approximate. Use certified print for exact dimensions. Design and materials are subject to change without notice.

Figure 145-1. Model EHU-701 with EHF-2 Fan Package — Front View

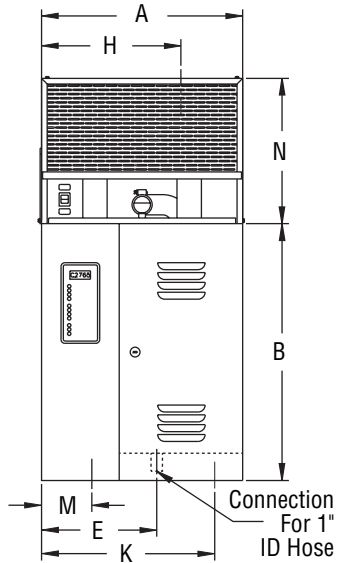

Figure 145-2. Model EHU-701 with EHF-2 Fan Package — Side View

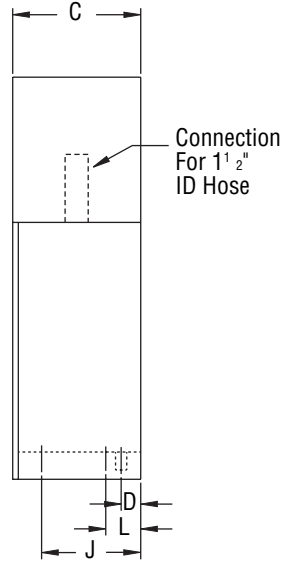
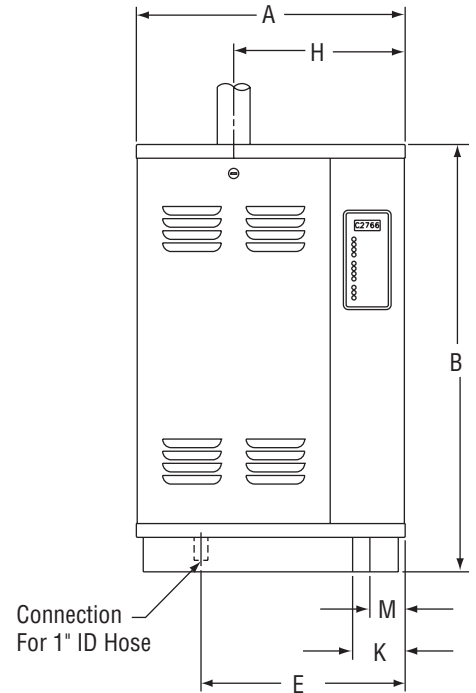

Figure 145-3. Model EHU-703 — Front View



Note: The EHF-3 is a remote mounted direct discharge unit.

Figure 145-4. Model EHU-704 — Front View

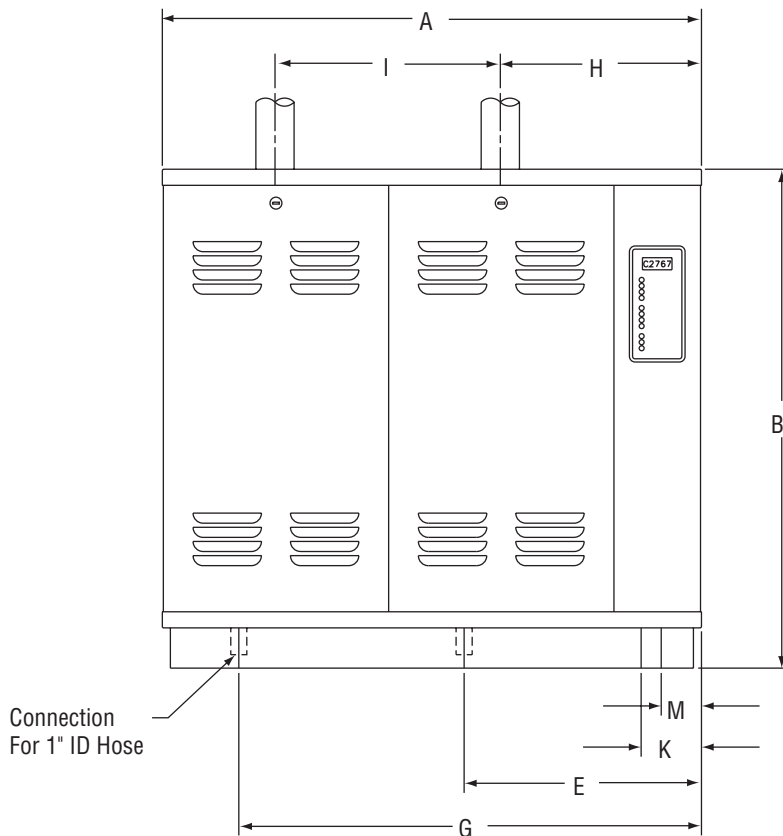
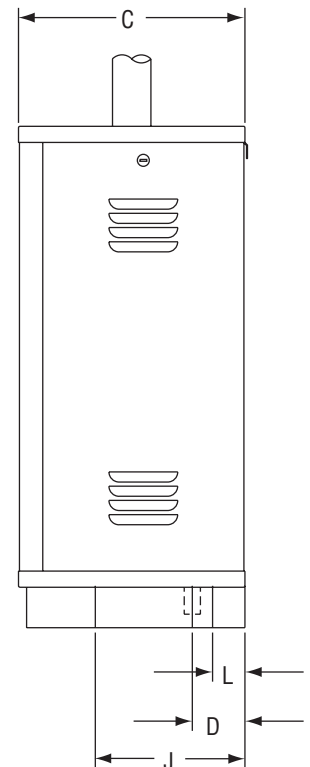

Figure 145-5. Model EHU-703 and 704 — Side View



All dimensions and weights are approximate. Use certified print for exact dimensions. Design and materials are subject to change without notice.