



# Armstrong® Float & Thermostatic Steam Trap

Steam Trapping and  
Steam Tracing Equipment

## The More Your Steam Pressure Varies, the More You Need Armstrong F&T Traps

When steam pressure may vary from maximum steam supply pressure to vacuum, Armstrong F&Ts are your most energy-efficient choice. Our line of F&Ts brings Armstrong performance, dependability and long life to trapping services requiring continuous drainage with high air venting capacity. Thanks to separate orifices for condensate and air, they provide continuous condensate drainage and air venting—even under conditions of zero pressure.

All the benefits detailed below have been designed into Armstrong F&Ts through long experience in the manufacture of pressure float-type drain traps. They assure you of optimum operating efficiency for long periods with minimum trouble.

### No water seal at inlet

Inlet high on body and condensate discharge valve in the bottom of the body prevent formation of a water seal that could block flow of air to vent under very low pressure conditions.

### Optional integral vacuum breakers

Provide maximum protection against freezing and water hammer in condensing equipment under modulated control. They also eliminate another fitting being installed in the line.

### Corrosion resistance

Entire float mechanism is made of stainless steel. The float is Heliarc welded to avoid the introduction of dissimilar metals, which could lead to galvanic corrosion and float failure.

### High-capacity venting of air and CO<sub>2</sub>

Built-in thermostatic air vent discharges large volumes of air and CO<sub>2</sub> through its separate orifice—even under very low pressure conditions.

### Long life and dependable service

Valve is stainless steel in all sizes. Seat is heat treated in 1-1/2" pipe size and larger. Rugged float mechanism is built to resist wear, and the stainless steel float provides exceptionally high collapsing pressure and resistance to hydraulic shock.

### Water sealed valve

Steam cannot reach condensate discharge valve because it is always under water. Balanced pressure thermostatic air vent closes on steam at any pressure within the operating range of the trap.

### Operation against back pressure

Trap operation is governed solely by the condensate level in the trap. Back pressure in the return line will not render the trap inoperative as long as there is any pressure differential to force condensate through the discharge valve.

### Continuous drainage

No pressure fluctuations due to intermittent condensate drainage. Condensate is discharged at very close to steam temperature. No priming needed.

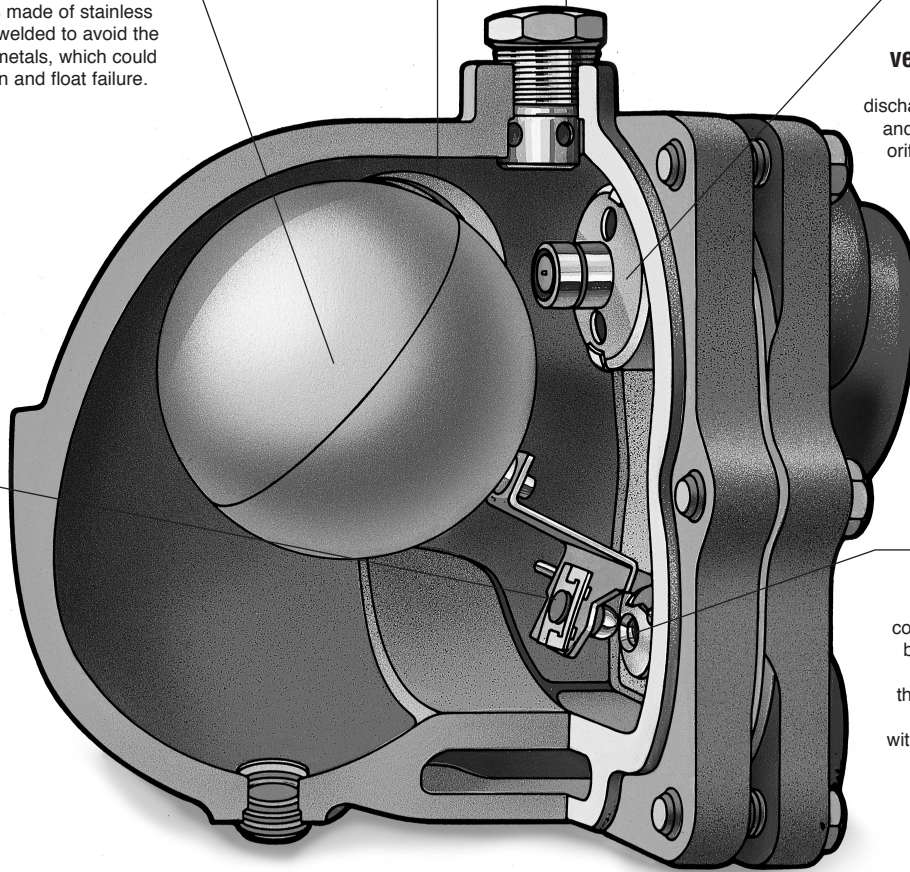

# Float & Thermostatic Steam Trap

## Built as Tough as the Jobs They Do

Armstrong float and thermostatic traps are unique in their super heavy duty construction. Armstrong uses high quality ASTM A48 Class 30 cast iron or ASTM A216 WCB cast steel—normally found in pressure vessels rated to 250 psi or 465 psi. Internal mechanisms are made from stainless steel and are heavily reinforced. No brass cotter pins here. Valves and seats are stainless steel, hardened, ground and lapped to withstand the erosive forces of flashing condensate.

Why go to all this trouble on traps normally recommended for low-pressure, modulating service? The answer is in the word *modulating*. Modulating pressures mean widely varying loads, thermal cycling and high air and non-condensable gas loads.

In other words, tough service. Inferior, lightweight construction is a mistake waiting to happen. Trap failures on modulating pressure may lead to water hammer, corrosion and even heat exchanger damage.

Armstrong's published capacities are based on actual measurements of traps handling hot, flashing condensate. Competitive F&Ts may utilize theoretical calculated capacities. Armstrong uses its own steam lab to give you actual capacity—especially important on high-capacity traps such as those in our ultra-capacity line. Not only does Armstrong offer super heavy duty construction for long life and reliability, but we also supply the data to back up performance. Here's a simple, easy-to-remember summary: The more your pressure varies, the more you need Armstrong F&Ts.

