

CD-3300 Series Disc Steam Traps

All Stainless With 360° Connector

For Steam Pressures to 450 psig (31 bar)...Capacities to 800 lb/hr (363 kg/hr)

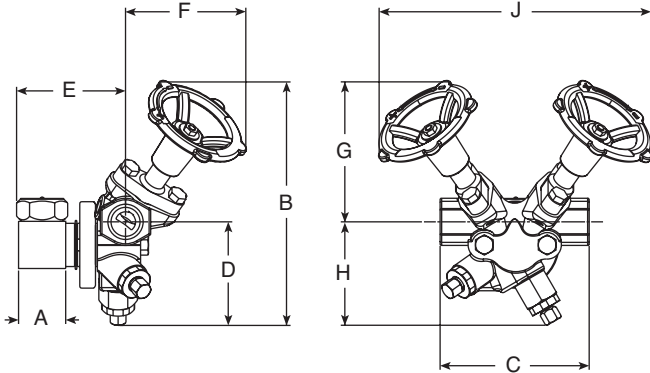

CD-3300 With TVS 4000 Trap Valve Station

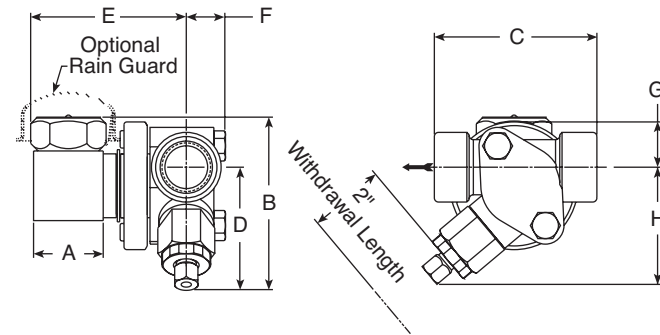

CD-3300 With IS-2 Connector With Integral Strainer and Blowdown Valve

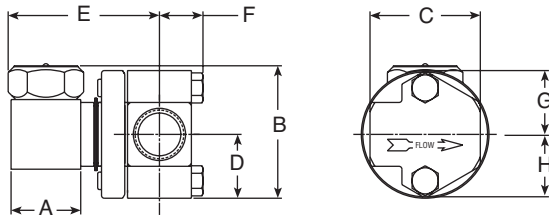

CD-3300 With Standard Connector

The Armstrong CD-3300 is a three discharge port design, which provides stable disc operation to extend operating life.

The CD-3300 is piped in-line by a 360° universal connector, which allows you to install the trap in virtually any piping configuration. Armstrong's unique standard connector or its IS-2 connector with integral strainer makes the CD-3300 easy to install, easy to renew. You save on labor time and cost because the connector simplifies piping and remains in-line.

Materials

Trap cap:	ASTM A743 CA40
Trap disc:	ASTM A276 Gr. 420
Trap body:	ASTM A276 Gr. 420
Standard connector:	Stainless steel—304
IS-2 connector with integral strainer:	ASTM A351 Gr. CF8 20 x 20 mesh 304 SS Screen

Options

- Rain guard insulating cap
- Blowdown valve—IS-2 connector only

For a fully detailed certified drawing, refer to CD #1164.

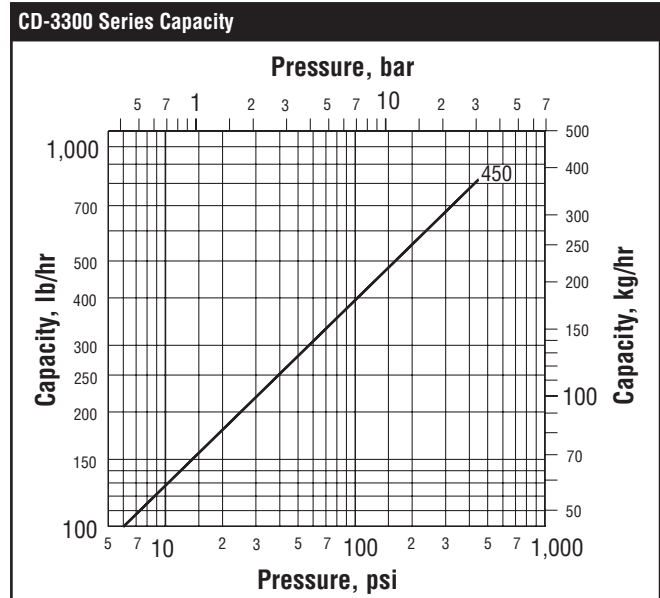

Model	CD-3300							
	Standard Connector		IS-2 Connector With Integral Strainer				TVS 4000 Connector	
	in	mm	in	mm	in	mm	in	mm
Pipe Connections	1/2, 3/4	15, 20	1/2, 3/4	15, 20	1	25	1/2, 3/4	15, 20
"A" Trap Diameter	1-1/2	38	1-1/2	38	1-1/2	38	1-1/2	38
"B" Total Height	2-7/8	73	3-3/4	94	3-3/4	94	7-13/16	198
"C" Face-to-Face	2-3/8	60	3-1/2	89	4	101	4-3/4	120
"D" Connection \varnothing to Bottom	1-3/8	35	2-5/8	67	2-5/8	67	3-1/4	83
"E" Connection \varnothing to Outside of Trap	3-3/8	86	3-3/8	86	3-9/16	90	3-9/16	90
"F" Connection \varnothing to Front of Connector	13/16	20	7/8	22	7/8	22	3-7/8	98
"G" Connection \varnothing to Top	1-3/8	46	1	25	1	25	4-1/2	114
"H" Connection \varnothing to Bottom of Connector	1-3/8	46	2-1/2	64	2-1/2	64	3-1/4	83
"J" Width Across Handwheels (Valve Open)	—	—	—	—	—	—	8-11/16	221
Test Port Connection	—	—	—	—	—	—	1/4 NPT	6
Trap Only Weight, lb (kg)	2 (0.91)							
Trap and Connector Weight, lb (kg)	3.6	1.6	3.9	1.8	4.2	2	8-1/2	3.8
Maximum Operating Pressure	450 psig @ 456°F (31 bar @ 236°C)							
Maximum Allowable Pressure (Vessel Design)	720 psig @ 750°F (50 bar @ 400°C)							

Designs, materials, weights and performance ratings are approximate and subject to change without notice. Visit www.armstronginternational.com for up-to-date information.