



# Armstrong® CD-33/CD-33S Disc Trap

Steam Trapping and  
Steam Tracing Equipment

### Durable

Hardened stainless steel integral seat and disc for long operating life.

### Adapts to outdoors

Optional rain guard insulating cap available to prevent excessive radiant heat loss in outside applications.

### Extended life

Three discharge port design offers stable disc operation to extend trap operating life.

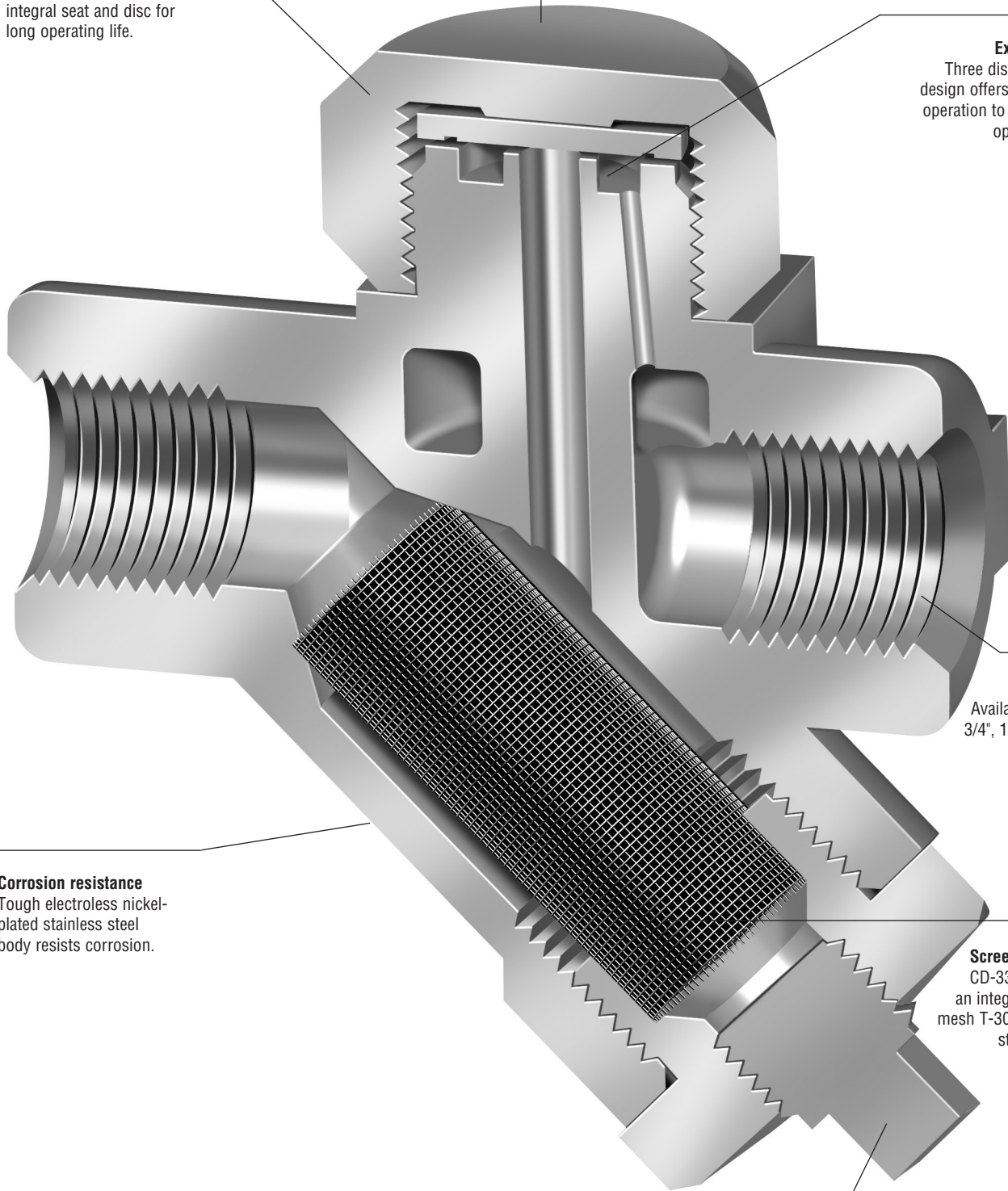

### NPT

Available in 1/2", 3/4", 1" NPT only.

### Corrosion resistance

Tough electroless nickel-plated stainless steel body resists corrosion.

### Screen included

CD-33S includes an integral 30 x 30 mesh T-304 stainless steel screen.

### Blowdown choice

Blowdown plug standard. Blowdown valve available as an option.

# CD-33/CD-33S Disc Trap



The Armstrong CD-33 is a disc style trap designed to control the trap's cycle rate. By reducing the cycle rate, the Armstrong CD-33 will have a longer service life than typical disc traps. This enhanced performance will ensure that maintenance time is minimized and steam costs are greatly reduced.

The CD-33 is designed with three discharge ports, which offer stable disc operation to extend trap operating life. The capacities of the Armstrong CD-33 have been engineered specifically for the following applications: large steam main drips, process equipment, and HVAC heating equipment on constant pressure. The CD-33L (low capacity) trap is designed for the low capacity applications of steam main drips and steam tracing lines. By ensuring that the capacities are designed to suit the application, and are not oversized, the CD-33 Series will last longer than other disc traps with excessive capacity ratings.

## Advantages

- Three discharge port design
- Minimum wear with controlled cycling
- Freeze-resistant
- Hardened seat and disc

## Specification

Steam trap shall be stainless steel thermodynamic type, integral seat design with hardened disc and seating surfaces, and electroless nickel plated finish. When required, trap shall be supplied with an integral Y strainer, integral blowdown valve or rain guard insulating cap. Maximum allowable pressure (vessel design) shall be 915 psig @ 752°F (63 bar @ 400°C). Maximum operating pressure shall be 600 psig @ 752°F (42 bar @ 400°C).

