

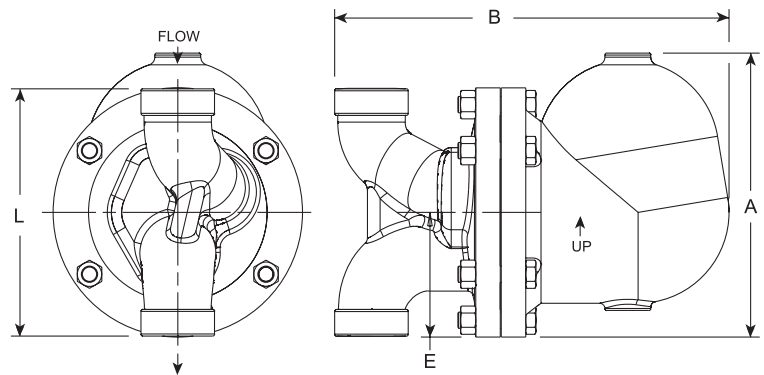

AIC Series Float & Thermostatic Steam Trap

Ductile Iron for Horizontal & Vertical Installation with Thermostatic Air Vent
For Pressures to 465 psig (32 barg)...Capacities to 60,075 lb/hr (27,250 kg/hr)

Steam Trapping and Steam Tracing Equipment

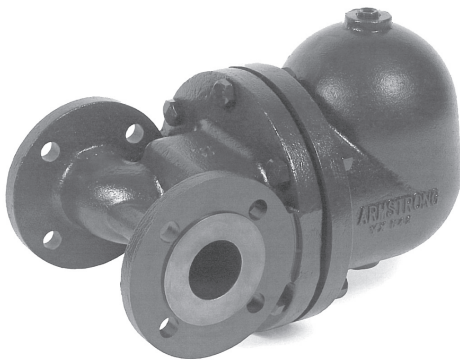

Model AICV

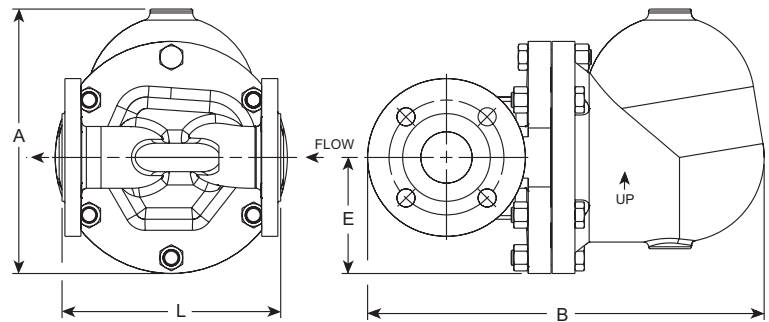

Model AICFH

Description

Armstrong AIC Series F&T traps are designed for industrial service up to 465 psig (32 barg). They feature all the benefits of Armstrong F&T traps, such as operation against back pressure, continuous drainage, high-capacity venting of air and CO₂, long life and dependable service and enjoys the convenience of in-line connections.

Armstrong AIC Series F&T traps are the perfect solution for applications where there is a need to vent air and non-condensable gases quickly under varying loads.

Maximum Operating Conditions

Maximum allowable pressure (vessel design)†: 580 psig @ 572°F
40 barg @ 300°C
Maximum Allowable Pressure: 580 psig (40 barg)
Maximum Allowable Temperature: 572°F (300°C)
Maximum Operating Pressure: 465 psig (32 barg)

† May be derated depending on flange rating and type.

Note: Caution should be used when Float and Thermostatic steam traps are applied in systems where freezing or excessive hydraulic shock can occur.

Connections

Screwed NPT and BSPT
Flanged ANSI and DIN

Materials

Body & Cap Ductile Iron
EN1563 EN-GJS-400-18U (ASTM A395)
Gasket Graphite
Seat Stainless Steel 17-4PH
Internals Stainless Steel
Valve Stainless Steel 17-4PH
Thermostatic Air Vent Hastelloy Wafer

Options

Integral vacuum breaker.
Add suffix VB to model number.

Flow Direction

Right to Left (Horizontal).
Top to Bottom (Vertical).

How to Order

Pressure	Model	Flow	Connection	Option
100 200 465HP	AIC AICF = Flanged Connection	H H = Horizontal V = Vertical	6 6 = 1-1/2" 8 = 2" 6 = DN40 8 = DN50	VB VB = Vacuum Breaker (limited to 150 psig/ 10 barg)

Available Connections and Face-To-Face Dimensions

Pipe Connections	1 1/2" DN40		2" DN50	
	in	mm	in	mm
"A" Height	10-15/16	278	10-15/16	278
"B" (Length Screwed)	12-27/32	326	13-1/8	333
"B" (Length Flanged)	16-1/8	410	16-27/64	417
"L" (Face-to-face Screwed)	10-5/8	270	11-13/16	300
"L" (Face-to-face Flanged PN40 ANSI CL150)	9-1/16	230	9-1/16	230
"L" (Face-to-face Flanged ANSI CL300)	9-3/32	231	9-1/4	235
"E" (Bottom to ⌀ of inlet)	4-13/16	122	4-13/16	122
Vacuum Breaker (optional)	1/2"	DN15	1/2"	DN15
Weight screwed lb (kg)	70-1/2 lb (32 kg)		70-1/2 lb (32 kg)	
Weight flanged lb (kg)	75 lb (34 kg)		75 lb (34 kg)	

Designs, materials, weights and performance ratings are approximate and subject to change without notice. Visit www.armstronginternational.com for up-to-date information.

AIC Series Float & Thermostatic Steam Trap

Ductile Iron for Horizontal & Vertical Installation with Thermostatic Air Vent

For Pressures to 465 psig (32 barg)...Capacities to 60,075 lb/hr (27,250 kg/hr)



Model AIC 1 1/2" Capacity

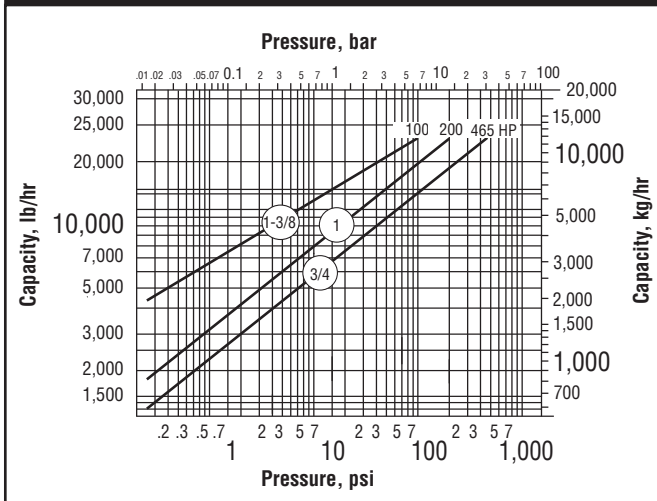

Model AIC 2" Capacity

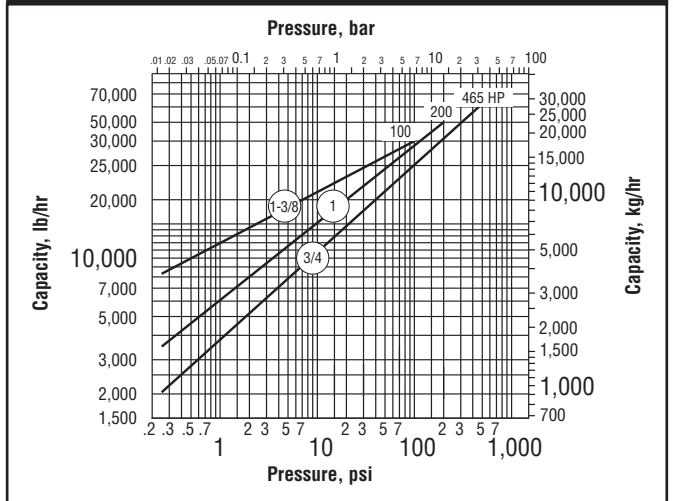

Options

Vacuum Breaker 1/2" NPT (DN15)

Many times, condensate will be retained ahead of steam traps because of the presence of a vacuum. To break a vacuum, air must be introduced into the system by means of a vacuum breaker.

For maximum protection against freezing and water hammer in condensing equipment under modulated control, vacuum breakers are recommended. Armstrong AIC Series F&T Traps are available with integral vacuum breakers. Maximum service pressure is 150 psig (10 bar).

Vacuum Breaker			
Size	in	mm	Max. allow. pres.
"B" Pipe Connections	1/2 NPT	DN15	150 psig (10 bar)
"C" Height	3/8 NPT	DN10	
"D" Width	1-1/4	32	
	7/8 Hex	22 Hex	

CAUTION: Do not use a conventional vacuum breaker open to the atmosphere in any system that incorporates a mechanical return system that carries pressure less than atmospheric pressure. This includes all return systems designated as vacuum returns, variable vacuum returns or subatmospheric returns. If a vacuum breaker must be installed in such a system, it should be of the type that is loaded to open only when the vacuum reaches a calibrated level well in excess of the design characteristics of the system.

Specification

The steam trap shall be an Armstrong model AIC (AICF) float & thermostatic type. Cap and body shall be EN1563 EN-GJS-400-15U (ASTM A395) Ductile Iron. Inline connections shall be integral to the cap as well as the internal mechanism. The valve and seat mechanism and float shall be stainless steel and repairable without disturbing the piping. The thermostatic Air Vent shall be a balanced pressure Hastelloy wafer with chrome steel seat. Maximum allowable back pressure should be 99% of the inlet pressure.

