

Benefits You Can See

Reduced maintenance

Stainless steel internals mean corrosion resistance and reduced maintenance.

Positive seating

Free-floating valve mechanism assures positive seating so it prevents air loss. There are no fixed pivots to wear or create friction, and wear points are heavily reinforced for long life.

In-line repairability

In-line connections and an O-ring seal make for quick, easy repairs without dismantling piping. Just unscrew and remove the body for maintenance.

Reduced need for cleaning

Recessed dirt pocket gives dirt a place to accumulate *away* from the valve seat. Valve seat is 1-1/4" above the dirt pocket. Compared to other ball float drain traps, the Armstrong 1-LDC reduces dirt fouling and needs less frequent cleaning.

Efficient operation

Simple ball float mechanism discharges only when liquid is present so it doesn't waste air.

An inside look

See-thru body means you can observe changing conditions as they occur. See a problem in the making—instead of having to deal with it after the fact.

Corrosion resistance

Long-lasting polysulfone body and reinforced nylon cap weigh less than 20% of cast iron liquid drain traps. Rugged polysulfone resists corrosion and provides long, trouble-free service life.

Simplified installation

Optional horizontal or vertical inlet with horizontal outlet eliminates the need for extra fittings. Makes installation in existing systems easier. Vertical inlet is 3/4" to accommodate air venting. Requires no electricity.

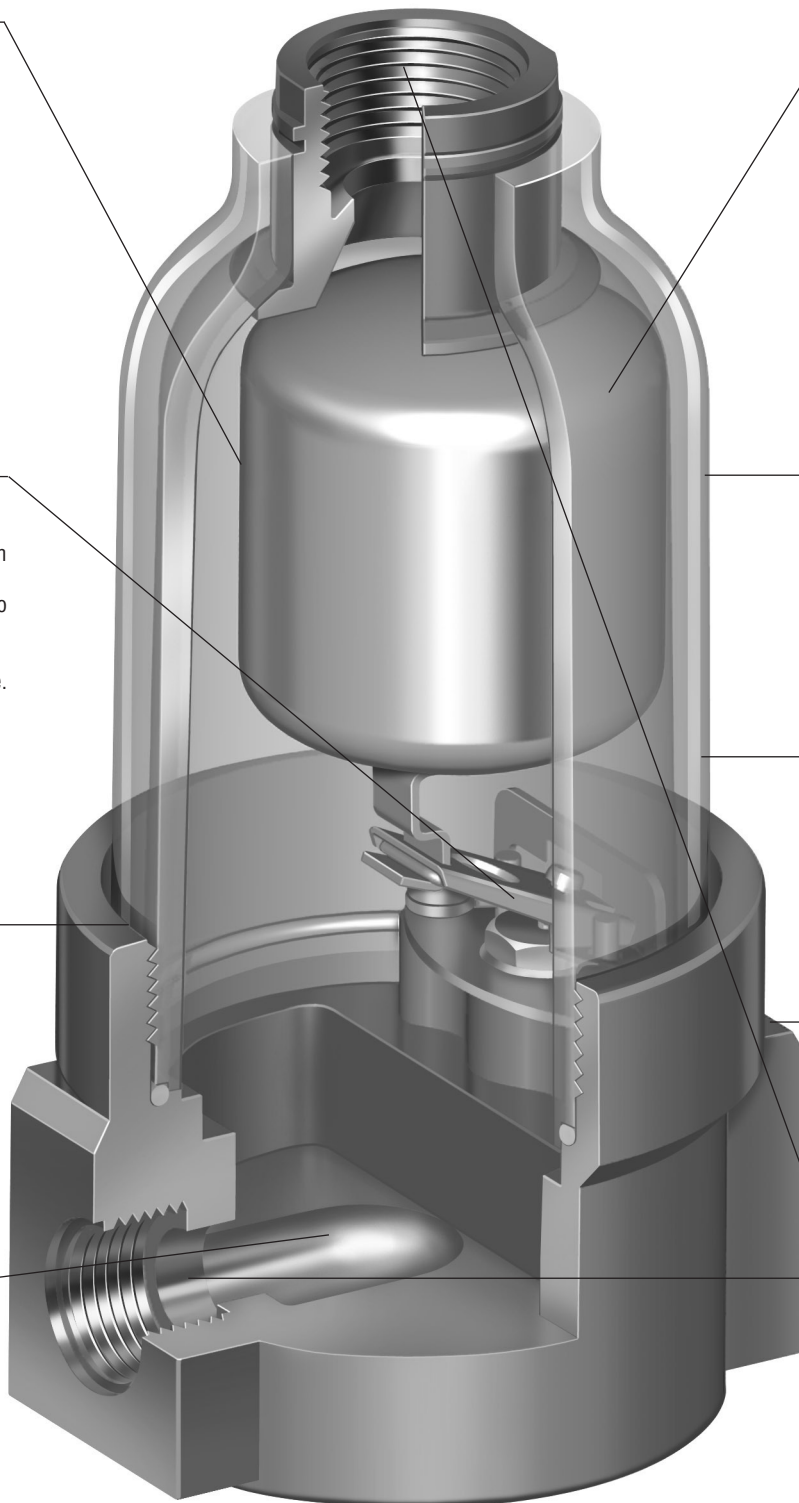

NOTE: The Armstrong 1-LDC is not recommended for extremely dirty systems or those with heavy oil carryover. The drain trap should not be used in an environment where there are high levels of ketones or chlorinated or aromatic hydrocarbons.

1-LDC—A See-Thru Body So You'll Know When It's Working



Now, you can literally see what you've been missing—the early warning signs of a drain trap or system problem. Since you'll know the operating condition of a drain trap, you won't waste time and money scheduling maintenance that isn't needed. In other words, you will be able to react to a condition before it becomes a problem.

A simple ball float mechanism requiring no electricity to operate, the new Armstrong 1-LDC discharges automatically only when liquid is present. That means no air loss as with timed devices, which open even when liquid is not present.

Moisture in a compressed air system causes a variety of problems—everything from dirt fouling and potential corrosion to water hammer. Getting the water out—automatically, reliably—builds greater efficiency into your system. In short, pay attention to your compressed air system, and you'll probably pay less to compress air.

Compare...and Save the Difference

Seeing really is believing—especially when you compare the Armstrong see-thru drain trap with cast iron units. Measure the differences in the time and money you can save with a more efficient, easier-to-maintain compressed air system. For more information or technical assistance, contact your local Armstrong Representative.



Liquid Drainers

Designs, materials, weights and performance ratings are approximate and subject to change without notice. Visit www.armstronginternational.com for up-to-date information.