



Free Floating Lever Dual Gravity Drain Traps

For Pressures to 1,000 psig (69 bar)

Armstrong free floating lever dual gravity drain traps are identical to the units described on pages LD-38 and LD-40 except float weights are modified to make them suitable for draining water from a light liquid. If you wish to use them for draining any liquid with specific gravity other than 1.00, consult the Armstrong Application Engineering Department.

Floats for dual gravity drain traps are weighted with quenching oil which, in the unlikely possibility of float failure, may be dispersed through the system. If this is a hazard, consult the Armstrong Application Engineering Department.

NOTE: Armstrong can design dual gravity traps for venting light liquids from above heavier liquids. Consult the Armstrong Application Engineering Department.

Viscosity Considerations for Dual Gravity Traps

The operation of dual gravity traps depends upon a float that will sink in the light liquid and float in the heavy liquid. When the specific gravities of the two liquids are very close, the available operating forces are, therefore, also very small. Viscous fluids may impair the ability of the trap to respond to changing liquid levels.

Consult Armstrong's Application Engineering Department if your application involves fluids more viscous than 70 cs, which is approximately the viscosity of a light machine oil.

Table LD-30. Maximum Operating Pressures for Draining Water From Different Specific Gravity Liquids With Orifices Available in Dual Gravity Drain Traps
(See pages LD-29 and LD-30.)

Model No.	Sp. Grav.	.50		.55		.60		.65		.70		.75		.80		.85					
	Float Wt, oz	6.0		6.5		7.0		7.5		8.0		8.5		9.1		9.6					
	Float Wt, g	170		184		199		213		228		242		257		271					
Orifice (in)	Maximum Operating Pressure																				
	psig		bar		psig		bar		psig		bar		psig		bar		psig		bar		
2-DG	5/16	15	1.0	12	0.9	10	0.7	9	0.6	7	0.5	5	0.35	—	—	—	—				
	1/4	25	1.6	20	1.4	18	1.2	15	1.0	12	0.8	9	0.6	6	0.4	—	—				
	3/16	50	3.6	45	3.0	40	2.6	30	2.2	25	1.8	20	1.4	12	0.9	7	0.45				
	5/32	90	6.0	75	5.5	65	4.6	55	3.8	45	3.0	35	2.4	22	1.6	12	0.8				
	1/8	150	10	130	9.0	110	8.0	90	6.5	75	5.0	55	4.0	40	2.6	20	1.4				
	7/64	190	13	170	12	150	10	120	8.5	100	6.5	75	5.0	50	3.4	25	1.8				
32-DG	Sp. Grav.	.50		.55		.60		.65		.70		.75		.80		.85					
	Float Wt, oz	8.8		9.6		10.3		11.1		11.9		12.7		13.5		14.3					
	Float Wt, g	248		271		293		315		338		360		382		405					
	Orifice (in)	Maximum Operating Pressure																			
		psig <td colspan="2">bar <td colspan="2">psig <td colspan="2">bar <td colspan="2">psig <td colspan="2">bar <td colspan="2">psig <td colspan="2">bar <td colspan="2">psig <td colspan="2">bar </td></td></td></td></td></td></td></td></td>		bar <td colspan="2">psig <td colspan="2">bar <td colspan="2">psig <td colspan="2">bar <td colspan="2">psig <td colspan="2">bar <td colspan="2">psig <td colspan="2">bar </td></td></td></td></td></td></td></td>		psig <td colspan="2">bar <td colspan="2">psig <td colspan="2">bar <td colspan="2">psig <td colspan="2">bar <td colspan="2">psig <td colspan="2">bar </td></td></td></td></td></td></td>		bar <td colspan="2">psig <td colspan="2">bar <td colspan="2">psig <td colspan="2">bar <td colspan="2">psig <td colspan="2">bar </td></td></td></td></td></td>		psig <td colspan="2">bar <td colspan="2">psig <td colspan="2">bar <td colspan="2">psig <td colspan="2">bar </td></td></td></td></td>		bar <td colspan="2">psig <td colspan="2">bar <td colspan="2">psig <td colspan="2">bar </td></td></td></td>		psig <td colspan="2">bar <td colspan="2">psig <td colspan="2">bar </td></td></td>		bar <td colspan="2">psig <td colspan="2">bar </td></td>		psig <td colspan="2">bar </td>		bar	
		5/16	25	1.6	20	1.4	18	1.2	15	1.0	12	0.9	10	0.7	7	0.5	—	—			
1/4		40	2.6	35	2.4	30	2.0	25	1.8	22	1.4	18	1.2	12	0.8	8	0.5				
3/16		90	6.0	75	5.0	65	4.6	55	3.8	45	3.2	35	2.6	25	1.8	18	1.2				
5/32		150	10	130	9.0	110	8.0	100	6.5	80	5.5	65	4.4	45	3.2	30	2.0				
1/8	250	17	225	15	200	13	170	11	140	9.5	110	7.5	80	5.5	50	3.4					
7/64	325	22	275	20	250	17	225	15	180	12	140	9.5	100	7.0	65	4.4					
3-DG to 250 psi* (17 bar) Cast Iron	Sp. Grav.	.50		.55		.60		.65		.70		.75		.80		.85		.90			
	Float Wt, oz	11.2		12.2		13.2		14.2		15.2		16.1		17.1		18.1		19.1			
	Float Wt, g	317		345		373		401		430		458		486		514		542			
	Orifice (in)	Maximum Operating Pressure																			
		psig <td colspan="2">bar <td colspan="2">psig <td colspan="2">bar <td colspan="2">psig <td colspan="2">bar <td colspan="2">psig <td colspan="2">bar <td colspan="2">psig <td colspan="2">bar </td></td></td></td></td></td></td></td></td>		bar <td colspan="2">psig <td colspan="2">bar <td colspan="2">psig <td colspan="2">bar <td colspan="2">psig <td colspan="2">bar <td colspan="2">psig <td colspan="2">bar </td></td></td></td></td></td></td></td>		psig <td colspan="2">bar <td colspan="2">psig <td colspan="2">bar <td colspan="2">psig <td colspan="2">bar <td colspan="2">psig <td colspan="2">bar </td></td></td></td></td></td></td>		bar <td colspan="2">psig <td colspan="2">bar <td colspan="2">psig <td colspan="2">bar <td colspan="2">psig <td colspan="2">bar </td></td></td></td></td></td>		psig <td colspan="2">bar <td colspan="2">psig <td colspan="2">bar <td colspan="2">psig <td colspan="2">bar </td></td></td></td></td>		bar <td colspan="2">psig <td colspan="2">bar <td colspan="2">psig <td colspan="2">bar </td></td></td></td>		psig <td colspan="2">bar <td colspan="2">psig <td colspan="2">bar </td></td></td>		bar <td colspan="2">psig <td colspan="2">bar </td></td>		psig <td colspan="2">bar </td>		bar	
		1/2	12	0.8	10	0.7	9	0.6	8	0.5	6	0.45	5	0.35	—	—	—	—			
3/8		25	1.8	22	1.6	20	1.4	15	1.2	12	0.9	10	0.7	7	0.5	—	—				
5/16		40	2.8	35	2.4	30	2.2	25	1.8	22	1.4	15	1.2	12	0.8	7	0.5				
9/32		55	3.6	45	3.2	40	2.8	35	2.4	30	2.0	22	1.6	15	1.0	9	0.6				
1/4	80	5.5	70	4.8	60	4.2	50	3.6	40	3.0	35	2.2	25	1.6	15	1.0					
7/32	110	8.0	100	7.0	90	6.0	75	5.0	60	4.2	45	3.2	35	2.4	20	1.4	7	0.45			
33-DG for all pressures	3/16	170	12	150	10	130	9.0	110	7.5	90	6.5	70	4.8	50	3.4	30	2.0	10	0.7		
5/32	275	19	225	16	200	14	170	12	140	10	110	7.5	80	5.5	45	3.2	15	1.0			
1/8	550	38	475	34	425	28	350	24	300	20	225	15	160	11	100	6.5	30	2.2			
7/64	700	48	600	42	525	36	450	32	375	26	275	20	200	14	120	8.5	40	2.8			
6-DG to 250 psi* (17 bar) Cast Iron	Sp. Grav.	.50		.55		.60		.65		.70		.75		.80		.85		.90			
	Float Wt, oz	52		57		62		67		72		77		82		87		92			
	Float Wt, g	1,483		1,622		1,760		1,899		2,038		2,177		2,316		2,455		2,594			
	Orifice (in)	Maximum Operating Pressure																			
		psig <td colspan="2">bar <td colspan="2">psig <td colspan="2">bar <td colspan="2">psig <td colspan="2">bar <td colspan="2">psig <td colspan="2">bar <td colspan="2">psig <td colspan="2">bar </td></td></td></td></td></td></td></td></td>		bar <td colspan="2">psig <td colspan="2">bar <td colspan="2">psig <td colspan="2">bar <td colspan="2">psig <td colspan="2">bar <td colspan="2">psig <td colspan="2">bar </td></td></td></td></td></td></td></td>		psig <td colspan="2">bar <td colspan="2">psig <td colspan="2">bar <td colspan="2">psig <td colspan="2">bar <td colspan="2">psig <td colspan="2">bar </td></td></td></td></td></td></td>		bar <td colspan="2">psig <td colspan="2">bar <td colspan="2">psig <td colspan="2">bar <td colspan="2">psig <td colspan="2">bar </td></td></td></td></td></td>		psig <td colspan="2">bar <td colspan="2">psig <td colspan="2">bar <td colspan="2">psig <td colspan="2">bar </td></td></td></td></td>		bar <td colspan="2">psig <td colspan="2">bar <td colspan="2">psig <td colspan="2">bar </td></td></td></td>		psig <td colspan="2">bar <td colspan="2">psig <td colspan="2">bar </td></td></td>		bar <td colspan="2">psig <td colspan="2">bar </td></td>		psig <td colspan="2">bar </td>		bar	
		1-1/16	12	0.9	12	0.8	10	0.7	9	0.6	8	0.5	6	0.4	—	—	—	—			
7/8		22	1.4	18	1.2	18	1.2	15	1.0	12	0.8	10	0.7	7	0.5	5	0.35				
3/4		30	2.2	25	1.8	25	1.6	20	1.4	18	1.2	15	1.0	10	0.7	7	0.5				
5/8		45	3.2	40	2.8	35	2.6	30	2.2	25	1.8	22	1.4	15	1.2	12	0.8	6	0.4		
9/16	60	4.2	55	3.8	50	3.4	40	2.8	35	2.4	30	2.0	22	1.4	15	1.0	8	0.5			
1/2	90	6.0	80	5.5	70	4.8	60	4.2	50	3.4	40	2.8	30	2.2	22	1.4	12	0.8			
36-DG to 1,000 psi (69 bar) Steel	7/16	130	9.0	110	8.0	100	7.0	90	6.0	70	5.0	60	4.0	45	3.0	30	2.0	15	1.2		
3/8	200	14	180	12	160	11	140	9.5	110	8.0	90	6.5	70	4.8	50	3.2	25	1.8			
11/32	275	18	250	16	200	14	180	12	150	10	120	8.5	90	6.5	65	4.4	35	2.4			
5/16	350	24	300	22	275	19	225	16	190	13	160	11	120	8.0	80	5.5	45	3.0			
9/32	450	32	400	28	350	24	300	20	250	18	200	14	160	11	110	7.5	60	4.0			
1/4	650	46	575	40	525	36	450	30	375	26	300	20	225	16	160	11	80	6.0			
7/32	950	65	850	55	750	50	650	44	525	36	425	30	325	22	225	15	120	8.5			
3/16	1,000	69	1,000	69	1,000	69	1,000	69	850	60	700	48	525	36	350	24	200	14			

NOTE: If actual specific gravity falls between those shown in the above table, use the next higher gravity. For example, if actual gravity is 0.73, use 0.75 gravity data.

*For vessel pressures above 250 psig (17 bar), always use steel drain traps.

Designs, materials, weights and performance ratings are approximate and subject to change without notice. Visit www.armstronginternational.com for up-to-date information.

Free Floating Lever Dual Gravity Drain Traps

For Pressures to 1,000 psig (69 bar)



List of Materials

Table LD-31.					
Model No.	Valve & Seat	Leverage System	Float	Body & Cap	Gasket
2-DG 3-DG 6-DG	Stainless Steel			Cast Iron ASTM A48 Class 30	Compressed Asbestos-free
32-DG 33-DG 36-DG				Forged Steel ASTM A105	

For information on special materials, consult the Armstrong Application Engineering Department.

For a fully detailed certified drawing, refer to:
 No. 2-DG, 3-DG, 6-DG CD #1034
 No. 32-DG, 33-DG, 36-DG CD #1035

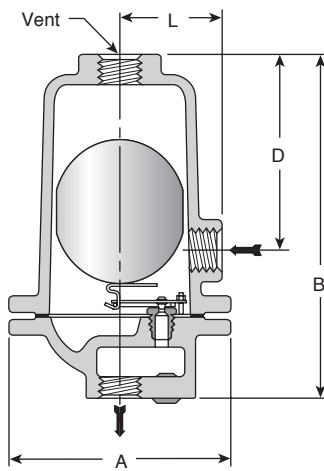

Figure LD-43.

No. 2-DG, 3-DG and 6-DG cast iron dual gravity drain traps.

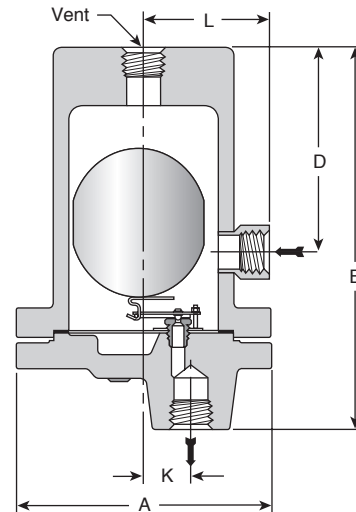

Figure LD-44.

No. 32-DG, 33-DG and 36-DG Forged steel dual gravity drain traps. Socketweld or flanged connections are also available.

Physical Data

Table LD-32. Armstrong Free Floating Lever Dual Gravity Drain Traps														
Model No.	Cast Iron						Forged Steel							
	2-DG		3-DG		6-DG		32-DG*		33-DG*		36-DG*			
Pipe Connections	in	mm	in	mm	in	mm	in	mm	in	mm	in	mm	in	mm
	1/2, 3/4	15, 20	1/2, 3/4, 1	15, 20, 25	1-1/2, 2	40, 50	1/2, 3/4, 1	15, 20, 25	1/2, 3/4, 1	15, 20, 25	1-1/2, 2	40, 50		
"A"	5-1/4	133	6-3/8	161	10-3/16	259	6-3/4	171	8	203	11-7/8	302		
"B"	8	203	10-5/8	270	17	432	10-3/16	259	11-9/16	297	17-1/8	435		
"D"	4-3/8	111	6-3/32	155	8-3/8	213	5-9/16	141	6-1/16	154	9	229		
"K"	—	—	—	—	—	—	1-1/4	32	1-7/16	37	2-1/8	54		
"L"	2-7/16	62	2-7/8	73	4-5/8	117	3-3/8	86	3-7/8	98	6-1/16	154		
Approx. Wt. lbs (kg)	13 (6)		22 (10)		80 (36)		31 (14)		49 (22)		163 (74)			
Maximum Allowable Pressure (Vessel Design)	250 psig @ 450°F (17 bar @ 232°C)						600 psig @ 100°F (41 bar @ 38°C) 500 psig @ 750°F (35 bar @ 400°C)		1,000 psig @ 100°F (69 bar @ 38°C) 600 psig @ 750°F (41 bar @ 400°C)					

* Available in Type 316 stainless steel. Consult factory.

Designs, materials, weights and performance ratings are approximate and subject to change without notice. Visit www.armstronginternational.com for up-to-date information.