

# Flow Indicator

## Ball Type Flow Indicators (BFI)

**Principle of Operation.** To monitor gas, air, oil, water and other fluids at both maximum and minimum flow rates. The action is simple and highly visible. The flow makes the white ball oscillate in the dome. If the flow stops, the ball drops out of sight. The movement of the ball cannot be missed even in poorly lighted areas and at significant distances, which eliminates guesswork. With only one moving part—the ball—there is nothing to go wrong.

**Sizes and Models.** The **Standard** type ball flow indicator is made in 1/2", 3/4" and 1" (15, 20, 25 mm) NPT-compatible sizes, having a die-cast brass body with a shatter-resistant borosilicate dome. The indicators are suitable for temperatures up to 180°F (82°C) and pressures up to 100 psi (7 bar).

The 1/2" (15 mm) BFI only is supplied as standard with special high-temperature joint rings and a glass-filled PTFE Teflon ball permitting use with temperatures up to 250°F (120°C).

The **High Pressure** model of the 1/2" (15 mm) BFI has an aluminum bronze body and high-pressure cap assembly for pressures up to 300 psi (21 bar) and contains a high-temperature ball for up to 250°F (120°C).

The **Stainless Steel** 1/2" (15 mm) BFI with Type 316 stainless steel body, high temperature ball and Teflon joint rings is suitable for use with pressures up to 100 psi (7 bar) maximum and temperatures up to 250°F (120°C) maximum.

## Flow Rates

**Installation.** The ball flow indicator must be installed horizontally with the glass dome upwards, so that the indicator ball will drop out of sight when the flow stops. It must be installed so that flow takes place in the direction of the arrow stamped on the indicator body.

**Large Diameter Pipes.** Flow is easily indicated in large diameter pipes by installing the Armstrong ball flow indicator in parallel with the large diameter pipe.

**Maintenance.** With only one moving part—the ball—there is practically no maintenance required.

## Shipping weights

1/2" BFI 2 lbs (0.9 kg)  
 3/4" BFI 4 lbs (1.8 kg)  
 1" BFI 4 lbs (1.8 kg)



With high-pressure cap

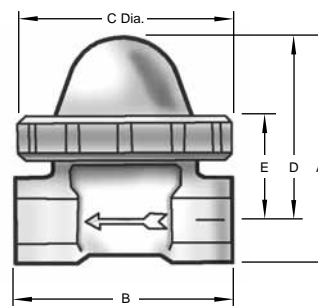

Drawing of the high-pressure version available upon request. This drawing shows the form of the 1/2" size. The 3/4" and 1" sizes are similar except for the shape of the cap.

Flow Rates				
Starting Flow				
Flow indicator size	Liquid		Gas	
	lpm	gpm	m <sup>3</sup> min	ft <sup>3</sup> min
1/2"	0.44	0.10	0.014	0.5
3/4"	0.70	0.15	0.056	2.0
1"	0.77	0.17	0.056	2.0

Dimensions					
Size	A	B	C	D	E
Dimensions in inches					
1/2	2-3/4	2-7/8	2-3/4	2-3/16	1-3/8
3/4 & 1	3-3/4	4-5/16	3-11/16	2-7/8	1-5/8
Dimensions in millimeters					
15	69	73	69	55	34
20 & 25	95	109	93	73	41

All dimensions and weights are approximate. Use certified print for exact dimensions. Design and materials are subject to change without notice.