



Armstrong® MegaMix™ Model E80W Water Temperature Mixing Unit

General Features

The 3-port valve utilizes a unique shear action disc technology and swirl-mix body geometry to provide high performance dynamic fluid mixing. The nature of the valve seat design minimizes disc wear, outperforming conventionally seated valves, minimizing seal replacement and plant downtime. Fitted with the electronic actuator and a temperature sensor inserted into the outlet pipe, the system delivers high-performance stand-alone closed-loop temperature control.

The calibrated temperature feedback signal in combination with the fast acting actuator provides temperature control accuracy to $\pm 2^\circ\text{F}$ ($\pm 1^\circ\text{C}$) over a 32°F - 212°F (0°C - 100°C) control range, capable of blending from 0% to 100% of either inlet temperature. Even with sudden changes of inlet pressure and temperature to the valve, the actuator controller aggressively minimizes outlet temperature variations, making the system ideal for use in industrial applications as a simple stand-alone or integrated mixing solution.

Valve Features

- ISO 5211, 5210 actuator flange mounting
- Shear Action Discs and Valve constructed of CF8M (316) stainless steel
- 3" valve flow coefficient (C_v): 144
- End connection: 3" ASME B16.5 Class 150 standard (Cl. 300 option available)
- Port size: 3" nominal bore
- Calibrated NTC temperature probe assembly requires fitting into pipework 12" downstream of the outlet port
- Elastomer seal material options are available to support NON water temperature control applications, e.g., glycol, hydraulic fluid
- Top entry allows inline access to internal valve parts
- Operating temperature range: -13°F to 257°F (-25°C to 125°C)
- Rated pressure: 232 psi (16 bar) at 212°F (100°C)
- Valve is non shutoff with seat leakage being less than 0.05% of C_v
- Design verification to ASME B16.34
- U.S. and EU patent pending

Electronic Actuator Features

- Analog (4-20mA) input and output control signals for interfacing with SCADA control
- Software configurable control settings
- Very high resolution capability (0.03° rotational)
- External RS232 connection (cable supplied)
- Stand-alone closed loop temperature control, or remote analog (4-20mA) control options
- Power: regulated 24Vdc 5-amp supply required
- Failsafe position feedback (non-contact absolute encoder)
- Keypad: 4 membrane switches with "dual touch" safety features
- Display: 3.5 digit LCD display with back light
- Push-button power switch
- Extra analog input for interfacing ancillary devices (e.g., flow switch, level switch)
- 90° stroke time as low as 1.5 seconds for fast control action
- Gearbox: planetary, lifetime lubrication, low backlash
- 100% duty cycle rated actuator

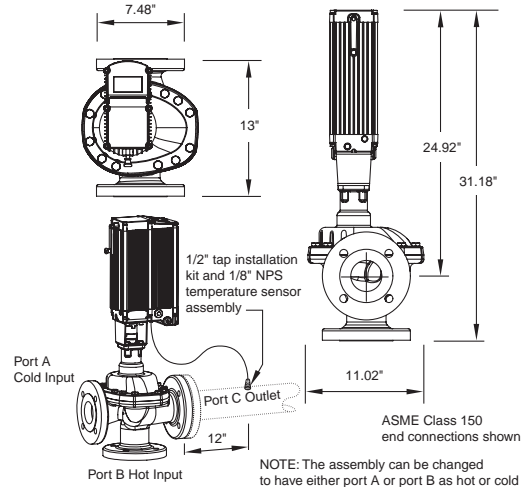
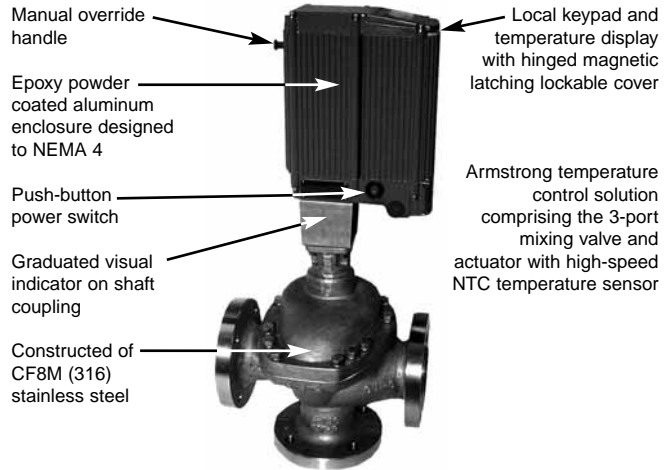

Important Notes:

Consult the "Installation, Operation and Maintenance" Manual (IOM) to review key requirements, recommendations and considerations when planning your installation. Failure to do so may affect the performance of the product. A copy of the IOM is provided with the product.

- Illustration shows standard system format for actuator/valve orientation, installed calibrated NTC temperature probe with installation tap kit and ASME B16.5 Class 150 end connections on the valve.
- Hot and cold input ports can be interchanged, and alternative orientations of the actuator on the valve can be specified.
- Class 300 flange option is available on indent, but not pressure rated to ASME CI 300.
- Please consult with the Armstrong factory at time of order placement if you require non standard format product for your installation.

For a fully detailed certified drawing, refer to CDLW #1172.

MegaMix™ Model E80W Water Temperature Mixing Unit

Shipping weight	128 lbs (incl packaging)
Shipping box size	15.8" x 33.7" x 17.5" (W x L x H)

Flow Capacity (gpm)

Model	Port Connection Sizes (NPT) Inlets x Outlet	Pressure Drop (psi)										Nominal Min. Flow (Note 4)	Max. Flow	C_v
		5	10	15	20	25	30	35	40	45	50			
E20W	3/4" x 1"	18	26	31	36	40	44	48	51	54	57	0.9	Note 2	8.1
E25W	1" x 1-1/4"	28	40	49	56	63	69	74	80	84	89	5.0	Note 2	12.6
E40W	1-1/2" x 1-1/2"	44	62	76	88	98	108	116	124	132	139	7.0	Note 2	19.6
E50W	2" x 2-1/2"	107	151	185	213	239	261	282	302	320	337	19.0	Note 2	47.7
E80W	3" x 3" (ASME B16.5 Class 150 Flanges)	322	455	558	644	720	789	852	911	966	1,018	53.0	Note 2	144

NOTE 1: Check valves MUST be installed on both inlets to the mixing system.
 NOTE 2: Sensible pipeline velocities are the only limit to the E80W mixing valve flows.
 NOTE 3: Contact Armstrong or visit Web site for Armstrong E80W valve sizing program and Application Notes.

NOTE 4: The nominal recommended Min. Flow is described as:
 • The minimum flow at which temperature control can be readily achieved for the given valve size with the Actuator set at STANDARD control gain setting.
 • Contact the factory for applications where flow conditions are lower than those stated above.

All dimensions and weights are approximate. Use certified print for exact dimensions. Design and materials are subject to change without notice.